

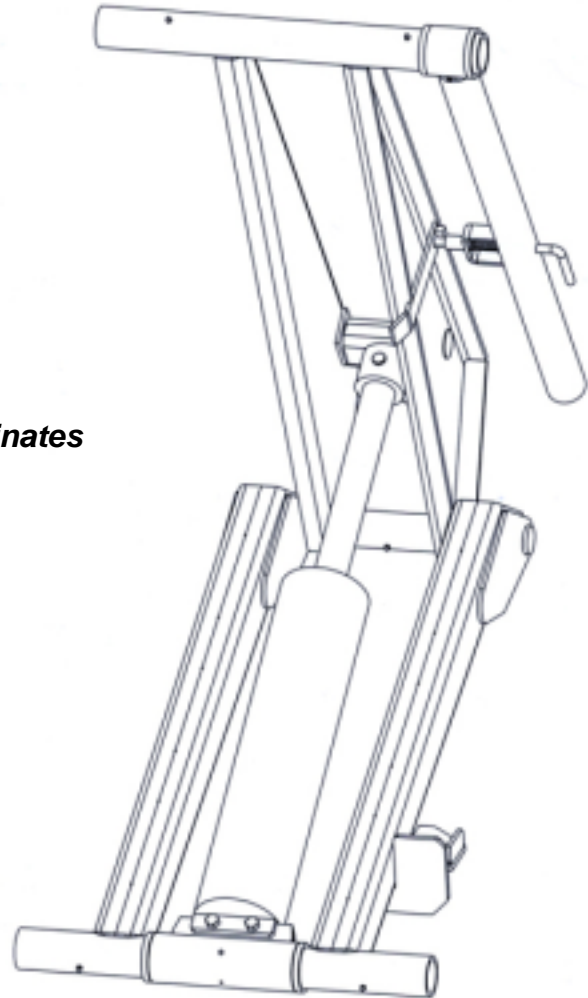

CONVERSION HOISTS VC620

For standard cab and chassis with
platform and dump bodies.

- *For 10' – 16' bodies.*
- *Capacities up to 18 tons.*
- *Single 6" cylinder and 20" stroke.*
- *Low mounting height scissors design eliminates interference with chassis components.*
- *Pre-installed self-locating body prop.*
- *Choice of pumps:
Electric single acting
Electric double acting
4 Piston PTO
Direct mount PTO*



- *Unitized quick mount hinge assembly.*
- *Completely assembled at factory to eliminate parts shortages and speed installation.*
- *All hoses, fittings, wiring and controls included.*

SPECIFICATIONS

VC620

- Conversion class E
- Dump class 50
- High pressure double acting cylinder with 6" bore x 20" stroke and multi-hard chromed and polished piston rod.
- Mounting height 7 1/2"
- Weight: 675 lbs.
- Choice of Pumps:
 - Direct mount gear PTO driven, SAE "A" 2 bolt flange, 5/8" - 9 spline shaft, 9 qt. reservoir.
 - 8 Piston PTO driven, 7/8" square shaft, 21 qt. reservoir.
 - Electric single acting, H.D. motor, 8 qt. reservoir.
 - Electric double acting, H.D. motor, 4 qt. reservoir.
 - Operating Pressure: 3000/1000 PSI

Body Length	C/A	Rear Overhang	Capacity (tons) 45° Dump*	Capacity (tons) 50° Dump*
10'	84"	6"	14.7	13.5
12'	84"	30"	18.9	17.4
12'	108"	6"	12.0	11.1
14'	108"	30"	14.7	13.5
14'	120"	18"	12.0	11.1
15'	108"	42"	16.5	15.2
15'	120"	30"	13.2	12.2
16'	120"	42"	14.7	13.5
16'	138"	24"	11.0	10.1
Mounting Distance			92"	84"

*CAPACITIES BASED ON WATER LEVEL LOAD, UNDIMINISHING, AND INCLUDES BODY WEIGHT.

ONE YEAR WARRANTY

This limited policy warrants new products of Venco to be free from defects in material and workmanship for a period of one (1) year from date of original installation. This warranty covers:

- ◆ Repair or replacement of product
- ◆ Labor to repair or replace product
- ◆ Freight to return and/or replace product

We shall not be liable for any contingent liabilities arising out of the improper function of any products. Warranty shall become void if the product is improperly installed, modified, damaged, abused or used for application other than intended use.

CAUTION: THE COMBINED WEIGHTS OF TRUCK, BODY, HOIST AND LOAD MUST NOT EXCEED THE GROSS VEHICLE WEIGHT RATING (GVWR) OF THE TRUCK.

A Product of:



MANUFACTURING, INC.

12110 BEST PLACE
CINCINNATI, OHIO 45241
PHONE: (800)226-2238
FAX: (513)326-5427

www.venturo.com

Email: sales@venturo.com

Distributed By: