

# TABLE OF CONTENTS

HT50KX / Std Ctrl / No Eng Ctrls (HSAAAA-00\*\*)

**SECTION 100** **DESCRIPTION & SPECIFICATIONS**

- 22343 INSTALLATION DIMENSIONS
- 18353 MOUNTING DIMENSIONS - BASE PLATE
- 22351 CAPACITY CHART - HT50KX

**SECTION 150** **SAFETY**

- 15394 VEHICLE & CRANE ELECTRICAL HAZARD INFORMATION
- 920612 SAFETY & HAZARDS - GENERAL
- 19217 WINCH SAFETY WARNINGS
- 22489 DECAL PLACEMENT

**SECTION 200** **INSTALLATION**

- 20697 CRANE INSTALLATION (PAGE 1 OF 2)
- 22344B CRANE INSTALLATION (PAGE 2 OF 2)
- 22345A CRANE OPERATION & MAINTENANCE INSTRUCTIONS (PAGE 1 OF 3)
- 22345B CRANE OPERATION & MAINTENANCE INSTRUCTIONS (PAGE 2 OF 3)
- 22345C CRANE OPERATION & MAINTENANCE INSTRUCTIONS (PAGE 3 OF 3)
- 22328 SAFETY SHUTOFF INSTRUCTIONS
- 22335 PTO INSTALLATION
- 20698 COMPARTMENT DRAWING
- 17831 INSTALLATION & MOUNTING DIMENSIONS - 17830 PEDESTAL
- 22245 WIRE ROPE INSTALLATION
- 20415A RADIO INSTALLATION / OPERATION INSTRUCTIONS - RADIO REMOTE (PAGE 1 OF 2)
- 20415B RADIO INSTALLATION / OPERATION INSTRUCTIONS - RADIO REMOTE (PAGE 2 OF 2)
- 20416 RADIO OPERATION INSTRUCTIONS

**SECTION 300** **MAINTENANCE & SERVICE**

- 14544 ADJUSTMENT OF WORM HEIGHT AND BACKLASH
- 14553 ADJUSTMENT OF ROTATION WORM END PLAY

**SECTION 400** **REPLACEMENT PARTS**

- 22346 HT40/50KX CRANE REPLACEMENT PARTS DRAWING
- 22517 HT40/50KX CRANE REPLACEMENT PARTS LIST
- 22518 HT40/50KX CRANE FASTENER LIST
- 24571 24550 BOOM (FULL POWER EXTENSION) REPLACEMENT PARTS DRAWING
- 24572 24550 BOOM (FULL POWER EXTENSION) REPLACEMENT PARTS LIST
- 20699 HYDRAULIC SYSTEM COMPONENTS REPLACEMENT PARTS DRAWING
- 20930 HYDRAULIC SYSTEM COMPONENTS REPLACEMENT PARTS LIST
- 22484 ELECTRICAL SCHEMATIC - STANDARD (NON-PROPORTIONAL)
- 20350 ELECTRICAL SCHEMATIC - NON-PROP W/ IN-COMP CONTROLS
- 22487 HYDRAULIC SYSTEM SCHEMATIC - STANDARD (NON-PROP) HT50KX
- 20278 20172 REPLACEMENT PARTS DRAWING
- 20417 RADIO REMOTE REPLACEMENT PARTS DRAWING WITH IN-COMPARTMENT CONTROLS
- 22449 22450 ANTI-TWO-BLOCK SYSTEM
- 22684 22685 ANTI-TWO-BLOCK SYSTEM (IN BOARD - LH)
- 22448 19294 PTO PACKAGE



TITLE	DATE	SECTION
TABLE OF CONTENTS	1-19-04	-
HT50KX (HSAAAA-00**)	SUPERCEDES	20996
	-	

**SECTION 100**

**DESCRIPTION**

**&**

**SPECIFICATIONS**

**WARNING: THESE PRODUCTS ARE NOT PASSENGER LIFTS. THEY ARE NOT DESIGNED OR INTENDED TO BE USED TO LIFT, SUPPORT, OR OTHERWISE TRANSPORT PERSONNEL.**

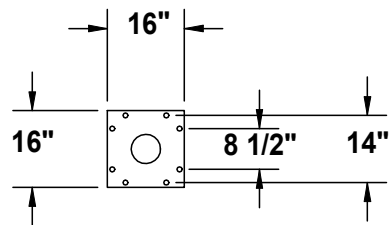

**BASE MOUNTING DIMENSIONS**

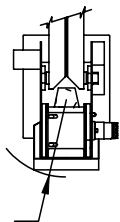

**16" SWING RADIUS**

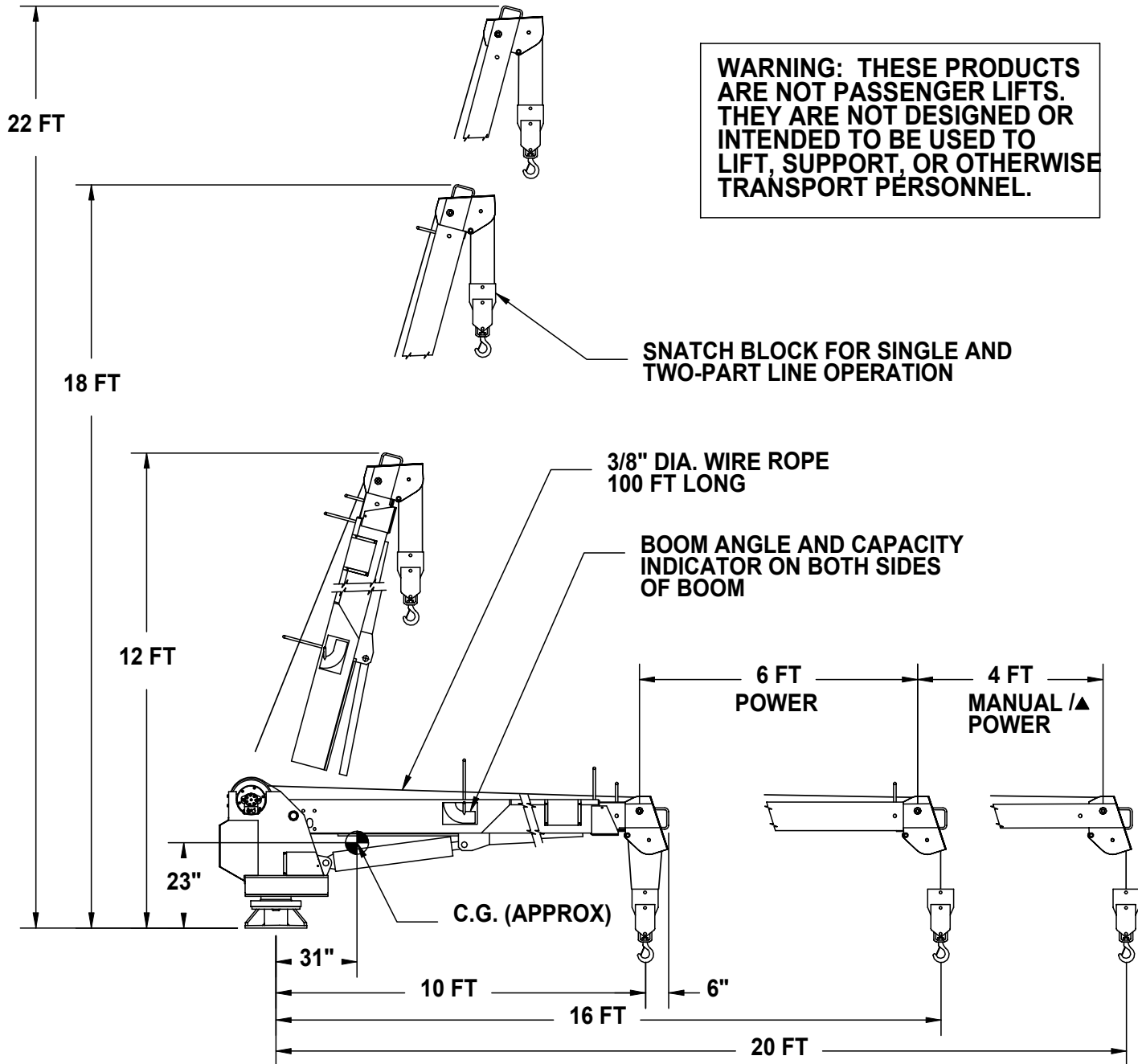
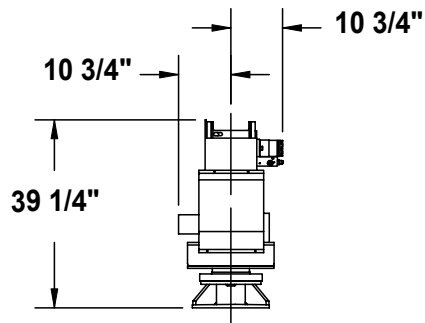

**SNATCH BLOCK FOR SINGLE AND TWO-PART LINE OPERATION**

**3/8" DIA. WIRE ROPE  
100 FT LONG**

**BOOM ANGLE AND CAPACITY INDICATOR ON BOTH SIDES OF BOOM**

**6 FT  
POWER**

**4 FT  
MANUAL /▲  
POWER**

**C.G. (APPROX)**

**TITLE  
INSTALLATION DWG**

**DATE  
3-3-03B**

**SECTION  
C100**

**HT40KX, HT50KX**

**SUPERSEDES  
10-21-97A**

**22343**



# HT40/50KX BASE MOUNTING DIMENSIONS

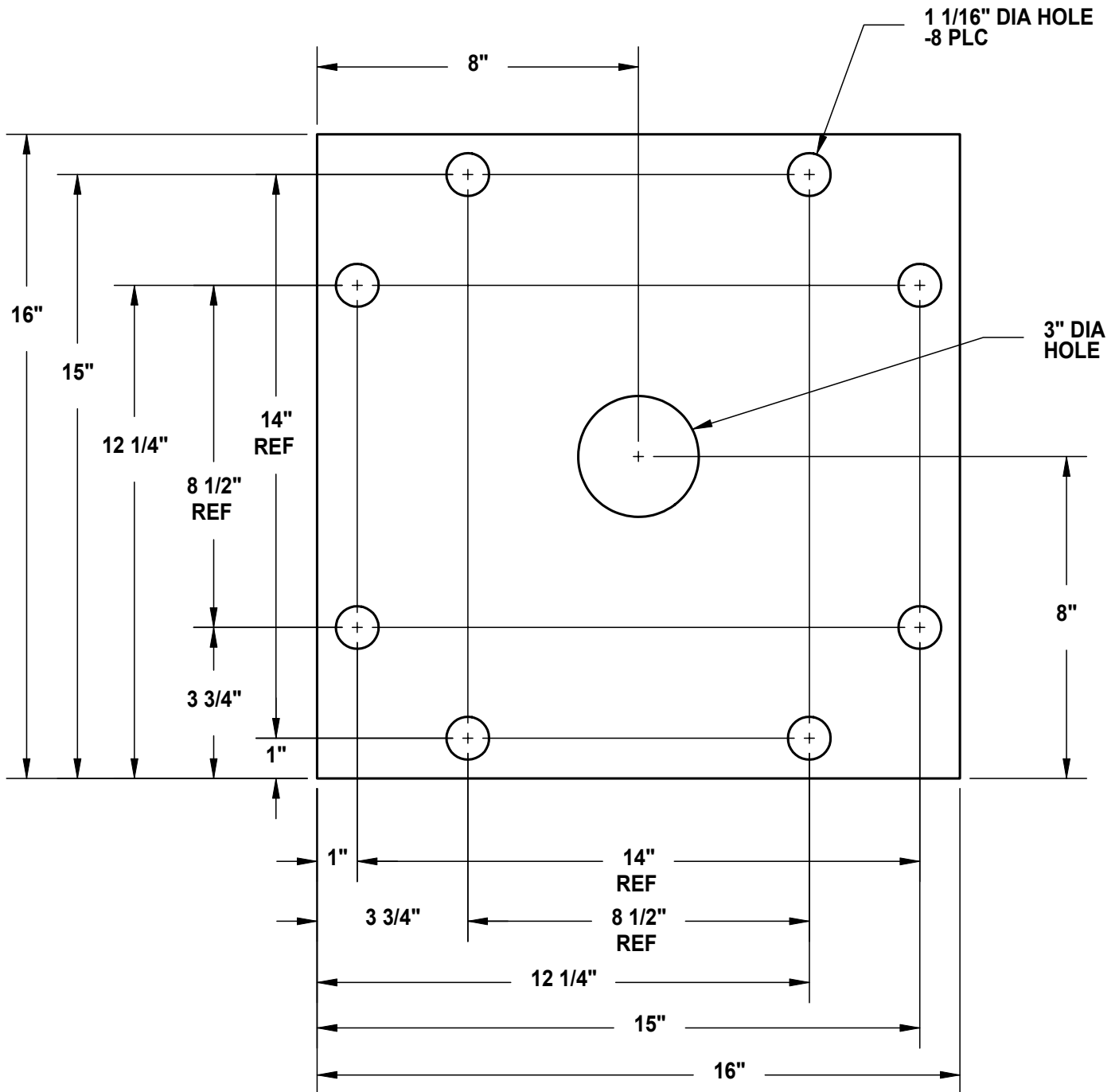

## HT50KX - 10-16-20 BOOM MAXIMUM CAPACITY CHART

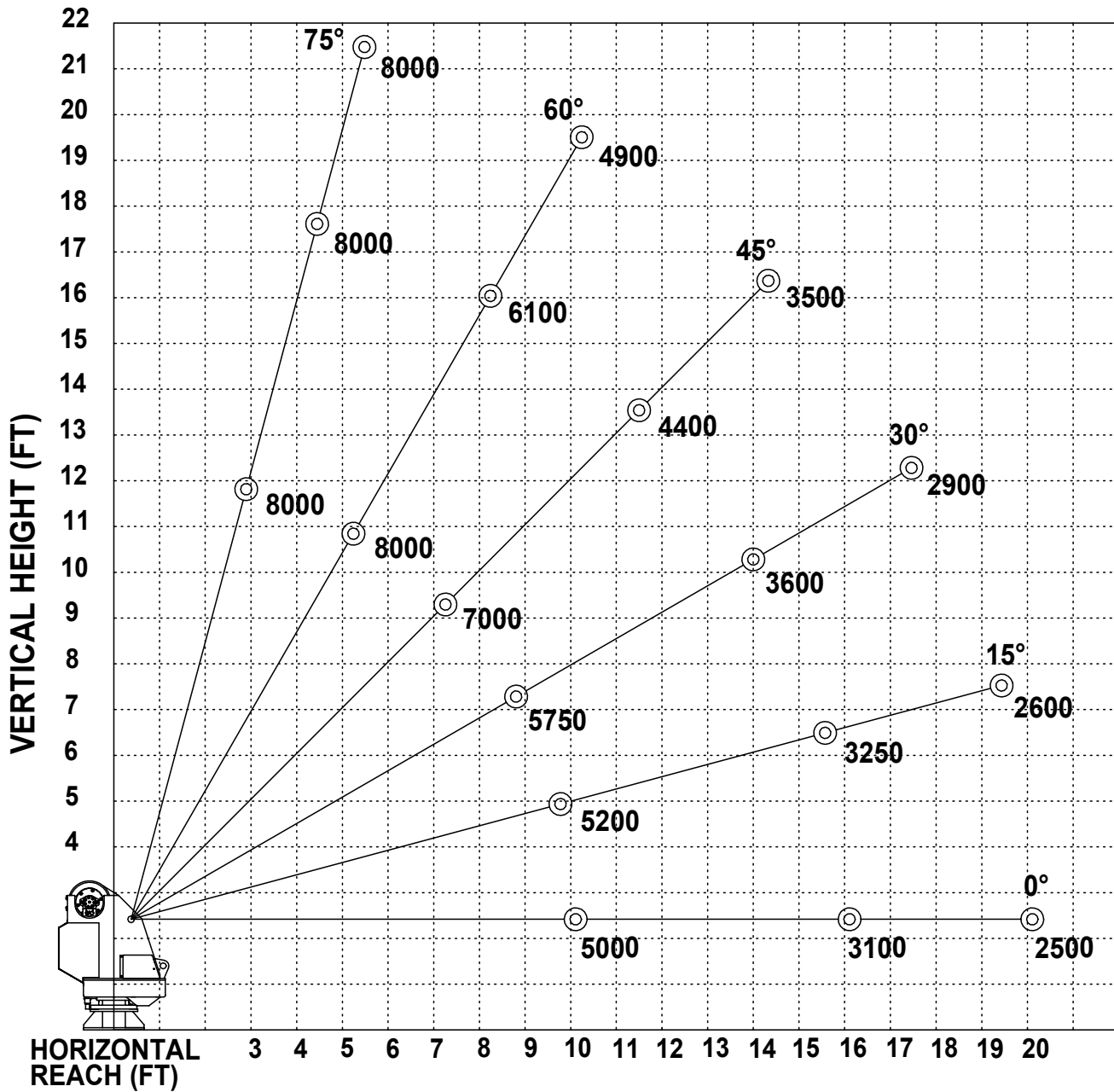

**MUST USE SNATCH BLOCK  
FOR LOADS OF 4000 LBS.  
AND GREATER**

# SECTION 150

## SAFETY

# VEHICLE & CRANE MOUNTED ELECTRICAL HAZARD SIGN APPLICATION & INFORMATION

ET & HT CRANE SERIES



▲ SIGN NO. 15393A DISPLAYS THE INTERNATIONAL SYMBOL FOR ELECTRICITY AND WARNS OF DANGER FROM AN ELECTRICALLY CHARGED VEHICLE, CRANE, OR LOAD. FOUR ARE RECOMMENDED (ONE FOR EACH SIDE AND ONE FOR EACH END OF VEHICLE) TO BE APPLIED IN LOCATIONS WHICH ARE READILY VISIBLE TO GROUND PERSONNEL.



▲ SIGN NO. 15401 PROVIDES ADDITIONAL WARNING OF LEGAL REQUIREMENTS WHEN OPERATING NEAR HIGH VOLTAGE LINES. THIS SIGN IS PLACED ON THE CONTROL PENDANT SIDE OF BOOM.

## REQUIRED MINIMUM CLEARANCES REFERRED TO ON SIGN NO. 15401

### REQUIRED CLEARANCES FROM OVERHEAD HIGH-VOLTAGE LINES

NOMINAL VOLTAGE (kV) (PHASE TO PHASE)	MINIMUM REQUIRED CLEARANCE (FEET) *
0 - 50	10
over 50 - 200	15
over 200 - 350	20
over 350 - 500	25
over 500 - 750	35
over 750 - 1000	45

### REQUIRED CLEARANCES FROM ENERGIZED HIGH-VOLTAGE CONDUCTORS (WHILE IN TRANSIT)

NOMINAL VOLTAGE (kV) (PHASE TO PHASE)	MINIMUM REQUIRED CLEARANCE (FEET) *
0 - 0.75	4
over 0.75 - 50	6
over 50 - 345	10
over 345 - 750	16
over 750 - 1000	20

\* NOTE: ENVIRONMENTAL CONDITIONS SUCH AS FOG, SMOKE, OR PRECIPITATION MAY REQUIRE INCREASED CLEARANCES



TITLE <b>INSTALLATION DWG</b>	DATE <b>5-15-02H</b>	SECTION <b>C150</b>
<b>ET &amp; HT CRANE SERIES</b>	SUPPERCEDES <b>5-13-97G</b>	<b>15394</b>

# CRANE SAFETY AND HAZARDS

HT25KX, HT40KX, HT50KX

## CAUTIONS

1. INSPECT VEHICLE AND CRANE, INCLUDING OPERATION, PRIOR TO USE DAILY.
2. DO NOT USE THIS EQUIPMENT EXCEPT ON SOLID, LEVEL SURFACE WITH CRANE MOUNTED ON FACTORY-RECOMMENDED TRUCK.
3. BEFORE OPERATING THE CRANE, REFER TO MAXIMUM LOAD (CAPACITY) CHART ON CRANE FOR OPERATING (LOAD) LIMITATIONS.
4. DO NOT OPERATE, WALK, OR STAND BENEATH BOOM OR A SUSPENDED LOAD.
5. ATTACH PENDANT CORD SUPPORT SNAP TO ATTACHMENT POINT BEFORE PLUGGING IN PENDANT.
6. UNPLUG PENDANT AND DISENGAGE PTO SYSTEM WHEN CRANE NOT IN USE.
7. FOR TRAVEL, BOOM MUST BE IN STOWED POSITION.

## DANGER

- THIS CRANE IS NOT A PASSENGER LIFT
- IT IS NOT DESIGNED OR INTENDED TO BE USED TO LIFT, SUPPORT, OR OTHERWISE TRANSPORT PERSONNEL.

## YOU MUST NOT OPERATE THIS CRANE UNLESS

1. YOU HAVE BEEN TRAINED IN THE SAFE OPERATION OF THIS CRANE  
*AND*
2. YOU KNOW AND FOLLOW THE SAFETY AND OPERATING RECOMMENDATIONS CONTAINED IN THE MANUFACTURER'S MANUALS, YOUR EMPLOYER'S WORK RULES, AND APPLICABLE GOVERNMENT REGULATIONS. AN UNTRAINED OPERATOR SUBJECTS HIMSELF AND OTHERS TO DEATH OR SERIOUS INJURY.

## ELECTROCUTION HAZARD

- THIS MACHINE IS NOT INSULATED.
- MAINTAIN SAFE CLEARANCES FROM ELECTRICAL LINES AND APPARATUS.
- YOU MUST ALLOW FOR BOOM SWAY, ROCK OR SAG, AND ELECTRICAL LINE AND LOADLINE SWAYING.
- THIS LIFTING DEVICE DOES NOT PROVIDE PROTECTION FROM CONTACT WITH OR PROXIMITY TO AN ELECTRICALLY CHARGED CONDUCTOR.
- YOU MUST MAINTAIN A CLEARANCE OF AT LEAST 10 FEET BETWEEN ANY PART OF THE CRANE, LOADLINE, OR LOAD, AND ANY ELECTRICAL LINE OR APPARATUS CARRYING UP TO 50,000 VOLTS. ADDITIONAL CLEARANCE IS REQUIRED FOR VOLTAGES IN EXCESS OF 50,000 VOLTS. REFER TO DRAWING 15394 FOR ADDITIONAL INFORMATION.
- **DEATH OR SERIOUS INJURY** WILL RESULT FROM CONTACT OR INADEQUATE CLEARANCE.



MFG., INC.  
CINCINNATI, OHIO

TITLE  
**INSTALLATION DWG**

DATE  
**5-13-97A**

SECTION  
**C150**

**HYDRAULIC CRANES**

SUPERCEDES  
**6-12-92**

**920612**



# WINCH SAFETY WARNINGS

	<p><b>⚠ DANGER</b></p> <p><b>DO NOT DISENGAGE WINCH UNDER LOAD</b></p>
	<p><b>⚠ DANGER</b></p> <p><b>THE LAST FIVE WRAPS OF WIRE ROPE MUST BE LEFT ON THE DRUM TO ASSIST THE WIRE ROPE CLAMP IN HOLDING THE LOAD</b></p>
	<p><b>⚠ WARNING</b></p> <p><b>WINCHES ARE NOT TO BE USED FOR THE LIFTING OR MOVING OF PERSONS</b></p>

**VENTURO**

MFG., INC.  
CINCINNATI, OHIO

TITLE  
INSTALLATION DWG

HT CRANES

DATE  
10-17-97A

SUPERCEDES  
7-30-96

SECTION  
C150

I19217

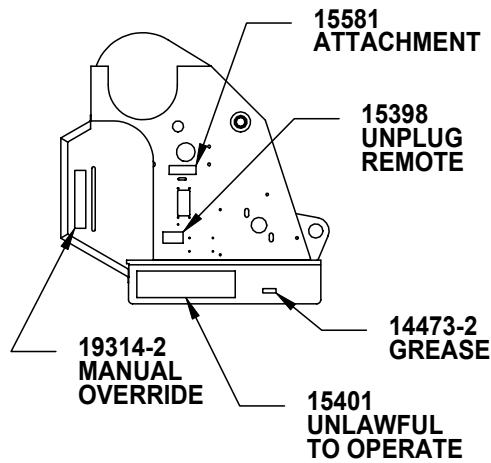

RIGHT

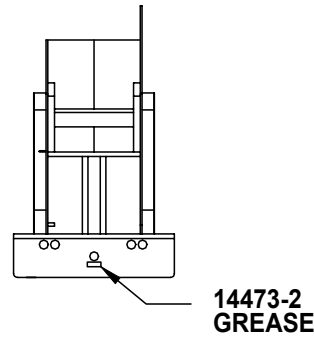

FRONT

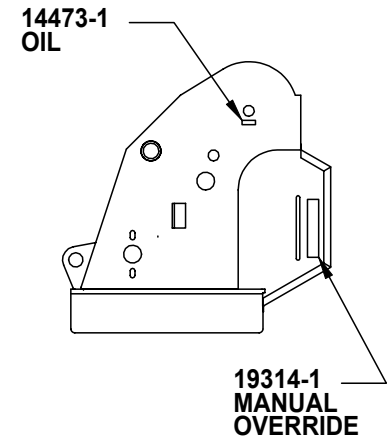

LEFT

MODEL NO.
19746 - HT40
19747 - HT50

CAPACITY		
DECAL	MODEL	PART NO.
RIGHT	HT40	22342-1
LEFT	HT40	22342-2
RIGHT	HT50	22352-1
LEFT	HT50	22352-2

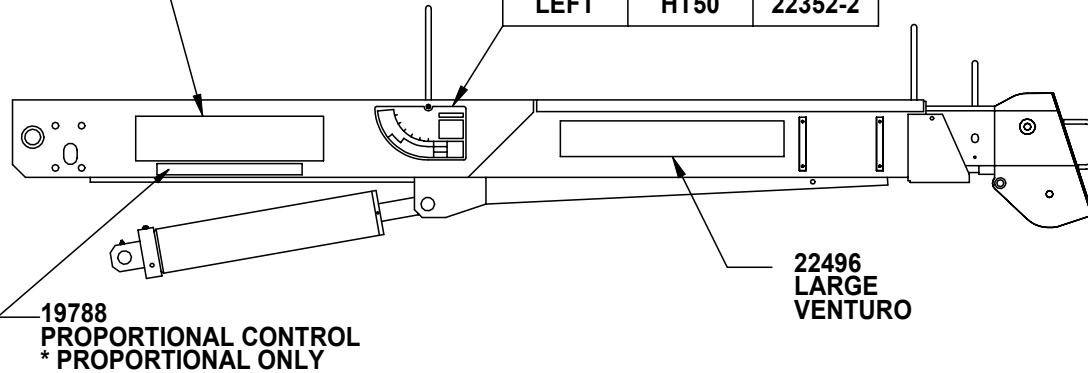

BOOM

SHUT OFF DECAL	
19315-1	MANUAL
19315-2	PROPORTIONAL

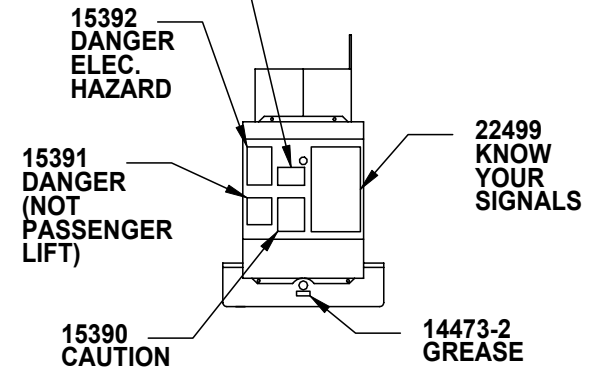

BACK

SERIAL NO. 84030 & UP  
SERIAL NO. 85030 & UP



TITLE  
DECAL PLACEMENT

HT40/50KX

DATE  
8-2-99B

SUPERSEDES  
5-25-99A

SECTION  
C150

22489

# SECTION 200

## INSTALLATION

## CRANE INSTALLATION

HT40KX, HT50KX

### BODY REINFORCEMENT

The truck body must be reinforced and outriggers provided to withstand the combined loads resulting from lifting and the weight of the crane and boom.

The maximum combined overturning moment for the HT40KX is 45,000 ft. lbs. and for the HT50KX is 55,000 ft. lbs.

The maximum vertical load for the HT40KX is 7900 lbs. and for the HT50KX is 9900 lbs.

### CRANE MOUNTING

The crane base plate or mounting pedestal must be bolted to the body reinforcing plate with eight (8) grade five (5) bolts of 1" dia. with either coarse or fine threads. A 7" dia. hose clearance hole must be cut in this plate to allow the hoses to swing and coil freely.

### ROTATION POSITIONING

The HT cranes are shipped with the boom rotated to the middle of the 400 degree rotation travel limit. The location of this middle position relative to the center line of the truck must be decided prior to mounting. It can be in any position that pleases the user since the boom can always reach the storage and travel position by rotating one way or the other.

### HYDRAULIC CONNECTIONS

The crane is furnished with a pressure and a return hose that come down through the center of the quill. Included in the installation kit are two hydraulic swivels and two more hoses. These hoses and swivels are to be arranged in the compartment or pedestal below the crane as shown on drawing 20698 using the angle bulhead fittings also furnished in the installation kit.

These hoses are to be connected in a relaxed position as shown on 20698, while the crane is at the midpoint of the 400 degree rotation range as received -- regardless of the final position of the boom during storage/travel.

The bulkhead fittings may be located on any side of the compartment relative to the middle of rotation position.

The crane pressure and return hoses have different sizes of SAE 37 degree flare swivel fittings. The smaller swivel is on the pressure hose which has a 3/8" flare (#6 JIC). The larger swivel is on the return hose which has a 1/2" flare (#8 JIC).



TITLE	INSTALLATION DWG	DATE	10-9-02	SECTION	C200
	HT40KX, HT50KX	SUPERCEDES	-		20697

## ELECTRICAL CONNECTIONS

A 25 ft. electrical power lead - intended for 12V DC only - also comes down through the center of the quill with the hoses. This lead should be looped in the compartment so that it remains relaxed throughout the 400 degree rotation of the crane.

A 15amp circuit breaker is mounted on the crane and protects the crane's internal wiring and solenoid coils. The 15amp circuit breaker does not protect the 25 foot electrical power lead. For added protection, the 25 ft. lead can be connected to a 15-20 amp protected circuit that, if possible, is powered only when the vehicle engine is running

## HYDRAULIC FLUID

Average Climate	Type of Oil
Cold to Moderate	ISO Grade AW 46
Warm to Hot	ISO Grade AW 68

The fluid should have the highest anti-wear characteristics and treated to inhibit rust and oxidation.

## HYDRAULIC HOSES & LINES

The minimum sizes for lines and hoses are as follows:

PRESSURE	3/8"
RETURN	1/2"
SUCTION	3/4"

## RESERVOIR

The PTO reservoir should have a capacity of 10 gallons fitted with 100 mesh suction screen, 10 micron return line filter, and filler/breather cap.

## PTO PUMP

The PTO pump should be sized to allow an engine idle speed range that will deliver approximately 2.5 GPM for the HT40KX standard (non-proportional), 5.0 GPM for the HT40KX proportional, 3.0 GPM for the HT50KX standard or 6.0 GPM for the HT50KX proportional. The crane's relief pressure is set at 3000 psi. ▲

## PTO START-UP

Before connecting the PTO system to the crane pressure and return hoses, connect the PTO pressure and return lines together at the bulkhead. Operate the PTO system for about two (2) minutes per gallon of reservoir capacity (in this case 20 minutes) to flush out the lines and filter all the fluid several times.

## ENGINE START/STOP & THROTTLE CONTROL

If your crane was purchased with optional engine start/stop and throttle control, refer to drawing 22615 in the replacement parts section for further information.



TITLE  
**INSTALLATION DWG**

DATE  
**7-22-02B**

SECTION  
**C200**

**HT40KX, HT50KX**

SUPERCEDES  
**8-12-99A**

**22344b**

# CRANE OPERATION AND MAINTENANCE INSTRUCTIONS

HT40KX, HT50KX

## SAFETY

Before operating this crane, read and understand these instructions, the 920612 Crane Safety and Hazards Information Sheet, and review all safety & instruction labels on the crane.

## CRANE INSPECTION

Before operating this crane, inspect for wear, damage, or oil leakage. After the wire rope has been run out, check for wear, kinks, and broken strands. Check the hook and safety latch for damage. Correct any problems before using the crane.

## CAPACITY

Before operating this crane, review the capacity charts on the sides of the boom to relate the load to be lifted to the boom length and angle. The boom angle is shown by a gravity arrow.

## SNATCH BLOCK

If the load exceeds 3000 lbs.-HT40KX or 4000 lbs.-HT50KX or if reduced winching speed for better control of smaller loads is required, use the snatch block to rig the crane for two part line operation.

## CONTROLS

This crane is operated by a remote control pendant. The pendant should be unplugged and stored in a compartment when the crane is not in use.

Before plugging the pendant in, inspect the plug, socket, cord, pendant head, and switches for damage. Actuate all four switches both ways to verify that they all have the same feel and sound and that they return to the center position.

Plug the pendant into the socket on the right side of the crane and snap the strain relief tether to the crane housing.

## PTO SYSTEM

Check the hydraulic fluid level in the PTO system reservoir. Engage PTO and set the engine idle speed to provide the desired hydraulic flow rate per the PTO system instructions. A lower idle setting may be used for more delicate spotting of loads if required.

## CRANE OPERATION

Use "Winch Down" to release tension on the wire rope to unhook it from the storage tie down position.

Use "Boom Up" to elevate the boom from the boom rest position.

Avoid repeated rapid reversals of the control switches. This can cause the load to swing.

Check all control functions to see that they are working as described in the following section.



MFG., INC.  
CINCINNATI, OHIO

TITLE  
**INSTALLATION DWG**

HT40KX, HT50KX

DATE  
**8-12-99B**

SUPERCEDES  
**7-17-97**

SECTION  
**C200**

**22345a**

## CONTROL FUNCTIONS

WINCH "UP" and "DOWN" - Raises and lowers the load with the winch.

BOOM "UP" and "DOWN" - Raises and lowers the boom elevation angle. The boom elevates from 8 degrees below horizontal to 75 degrees above horizontal.

BOOM "OUT" and "IN" - Extends and retracts the boom. The boom hydraulic extension stroke is 6 ft.

ROTATION "L" and "R" - Controls the left and right direction of the crane rotation. The crane rotation is limited to 400 degrees.

POWER - (Non Proportional Systems) Energizes safety shutoff valve. See page 22328 for detailed operations instructions and warnings.

TRIGGER (Proportional Systems Only) - Varies the flow rate delivered to the crane valve. The farther the trigger is pulled, the faster the selected crane function operates.

## OVERLOAD SENSING SYSTEM

This crane is equipped with an Overload Sensing System. If the capacity of the crane is exceeded, the "Winch Up", "Boom Down", and "Boom Out" functions will be shut down. The "Winch Down", "Boom Up", and "Boom In" functions will continue to operate and can be used to relieve the overload condition. The "Rotation" function also will continue to operate.

For crane models HT25 serial numbers 80157, HT40 serial numbers 84092 and HT50 serial numbers 85086 and below, the Overload system is inoperative if the boom elevation is at the bottom or top limit of travel. To relieve this condition, raise or lower the boom slightly before lifting the load. Cranes with serial numbers above the aforementioned have been modified to allow the Overload system to remain active at the top of boom travel.

## TWO-BLOCK SENSING SYSTEM

This crane is equipped with an anti two-block device that is mounted at the tip of the boom. If the snatch block/overhaul weight contacts the device the "Winch Up", "Boom Down", and "Boom Out" functions are disabled. The "Winch Down", "Boom Up", and "Boom In" functions will continue to operate and can be used to relieve the two-block condition. Refer to Drawing 22449 for replacement parts and configuration information.

## MANUAL TELESCOPIC BOOM

The 10 to 20 ft. boom has a 4 ft. manual telescoping section in addition to the 6 ft. power extension. A pin locks the manual extension into either the extended or retracted position.

## ▲ POWER TELESCOPIC BOOM

The 10 to 20 ft. boom has a 4 ft. power telescoping section in addition to the 6 ft. power extension.

## TRUCK SETUP & OUTRIGGERS

1. The truck should be parked on ground that is as level and as firm as possible when using the crane.
2. The center of the crane should be positioned close enough to the job so that it can be operated at a reach that puts the load within the rated capacity of the crane.



MFG., INC.  
CINCINNATI, OHIO

TITLE  
**INSTALLATION DWG**

**HT40KX, HT50KX**

DATE  
**3-4-03E**

SUPERCEDES  
**11-3-00D**

SECTION  
**C200**

**22345b**

- ▲ 3. Set the vehicle parking brake and put the vehicle transmission in "park" if it is an automatic.
- 4. Deploy the outriggers to help stabilize the vehicle against rocking or overturning when lifting with the crane.

### PREPARATION FOR TRAVEL

1. Return the outriggers to the stowed position. Install and secure all pins.
2. Stow the crane boom in the boom support.
3. Hook the winch line to a tie down point on the body or pedestal and apply tension.
4. Disengage the PTO pump and idle speed control.
5. Unplug the control pendant and store in a body compartment or the cab.

### MAINTENANCE

The crane requires only periodic lubrication. As a standard procedure, this can be done at the time the vehicle is serviced.

The winch planetary gearbox lube should be maintained at the level plug.

To ensure optimal winch performance, the following lube schedule and lube specifications should be followed:

Initial Change - after 6 weeks or 10 hours of operation.

Periodic Change - on an annual basis or every 50 hours of operation.

<u>Temp Range (°F)</u>	<u>Winch Hydraulic Oil</u>
120 to 10	SAE 50
40 to -25	75W90
30 to -50	Conoco DN600 or equivalent

Service grease fittings and rotation gear with molybdenum-disulfide graphite-filled lithium-based extreme pressure grease.

Grease fitting locations:

- Boom pivot at rear of boom (two grease fittings)
- Upper quill bearing
- Elevation cylinder tail clevis
- Rotation worm shaft - each side of lower part of crane housing
- Rotation shaft bearing - near elevation cylinder lower pivot

The rotation drive chain should be oiled lightly (DO NOT GREASE).

The lower quill bearing is self lubricating.

Remove rear cover and check all hydraulic tube and hose fittings for tightness.

Check electrical connections for looseness and corrosion.



TITLE	DATE	SECTION
INSTALLATION DWG	3-12-03C	C200
HT40KX, HT50KX	<small>SUPERCEDES</small> 8-12-99B	<b>22345c</b>



## EXPLANATION OF HYDRAULIC VALVE SYSTEM

### OVERVIEW

Venturo's hydraulic cranes are available in two general configurations: Proportional and Non-proportional. The **Non-proportional** configuration utilizes a safety shutoff valve which, when **not** actuated, allows hydraulic fluid to bypass the valve bank and return to tank; the crane will not function when the safety shutoff valve is not actuated. When the safety shutoff valve is actuated (control pendant energizes the coil or the coil is manually overridden), hydraulic fluid cycles through the valve bank and allows the crane to function. The **Proportional** configuration utilizes a proportional valve which in its fully closed and fully opened positions functions similarly to the safety shutoff valve, but adds the ability to operate the crane at any speed in between these two extremes.

In both the Non-proportional and Proportional configurations, the four crane functions (winch, rotation, boom elevation, and boom extension) are controlled by four separate valve sections. Each valve section has two solenoid coils (and two manual overrides) which control the direction that the function operates (e.g. winch up vs. winch down). For a given crane function and direction (e.g. winch up) the solenoid coil and the associated manual override lie on the same side of the valve bank (both "push").

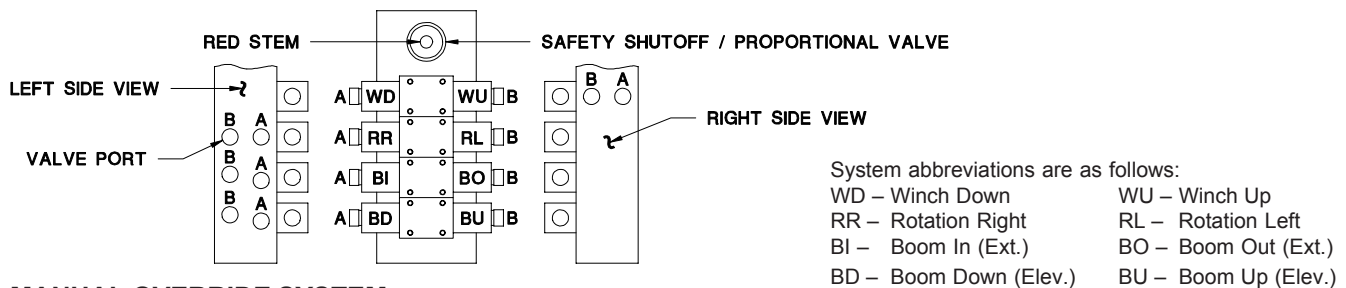

### MANUAL OVERRIDE SYSTEM

Should an electrical failure occur, your Venturo crane can be operated manually. **The manual overrides are intended for emergency use only and should not be used for normal operation.**

#### To operate in manual override mode:

- Override the safety shutoff or proportional valve by turning the red stem on the valve as stated below.

#### Non-proportional system:

For override operation, press stem in and rotate counterclockwise until it stops.

To return to normal operation, press stem in and rotate clockwise until it stops.

#### Proportional system:

For override operation, rotate stem clockwise (the farther the stem is turned the faster the crane will operate).

To return to normal operation, rotate the stem counterclockwise until it stops.

- Determine the coil/override associated with the function you wish to operate, then insert a small diameter object (an allen wrench works well) into the detent on the end of the valve stem and press firmly inward. For example, pushing the stem labeled A on the first bank (refer to the illustration) will actuate winch down.

**WARNING!** For normal crane operation, the safety shutoff or proportional valve must be in the "normal" position (as described above). Test the crane before each use by placing the power toggle switch or trigger in the "OFF" position and testing each crane function *using the manual overrides*. If any crane function operates, verify that the red stem on the safety shutoff or proportional valve is in the normal position then retest.

### EMERGENCY STOP

In the unlikely event that a function of the crane does not stop once the function's toggle switch is released, the **Non-proportional** crane can be stopped by simply toggling the power switch to the off (emergency stop) position and the **Proportional** crane can be stopped by releasing the trigger.



MFG., INC.  
CINCINNATI, OHIO

TITLE  
**HYDRAULIC SYSTEM**

▲HT18, HT25, HT40/50

DATE  
**9-24-03B**

SUPERCEDES  
**5-1-98A**

SECTION  
**C200**

**22328**



**CAUTION: THE RETURN LINE FROM THE CRANE MUST HAVE AN UNRESTRICTED PATH TO TANK/RESERVOIR.**

FOR INFORMATION ON OUR PTO PACKAGES REFERENCE 22448

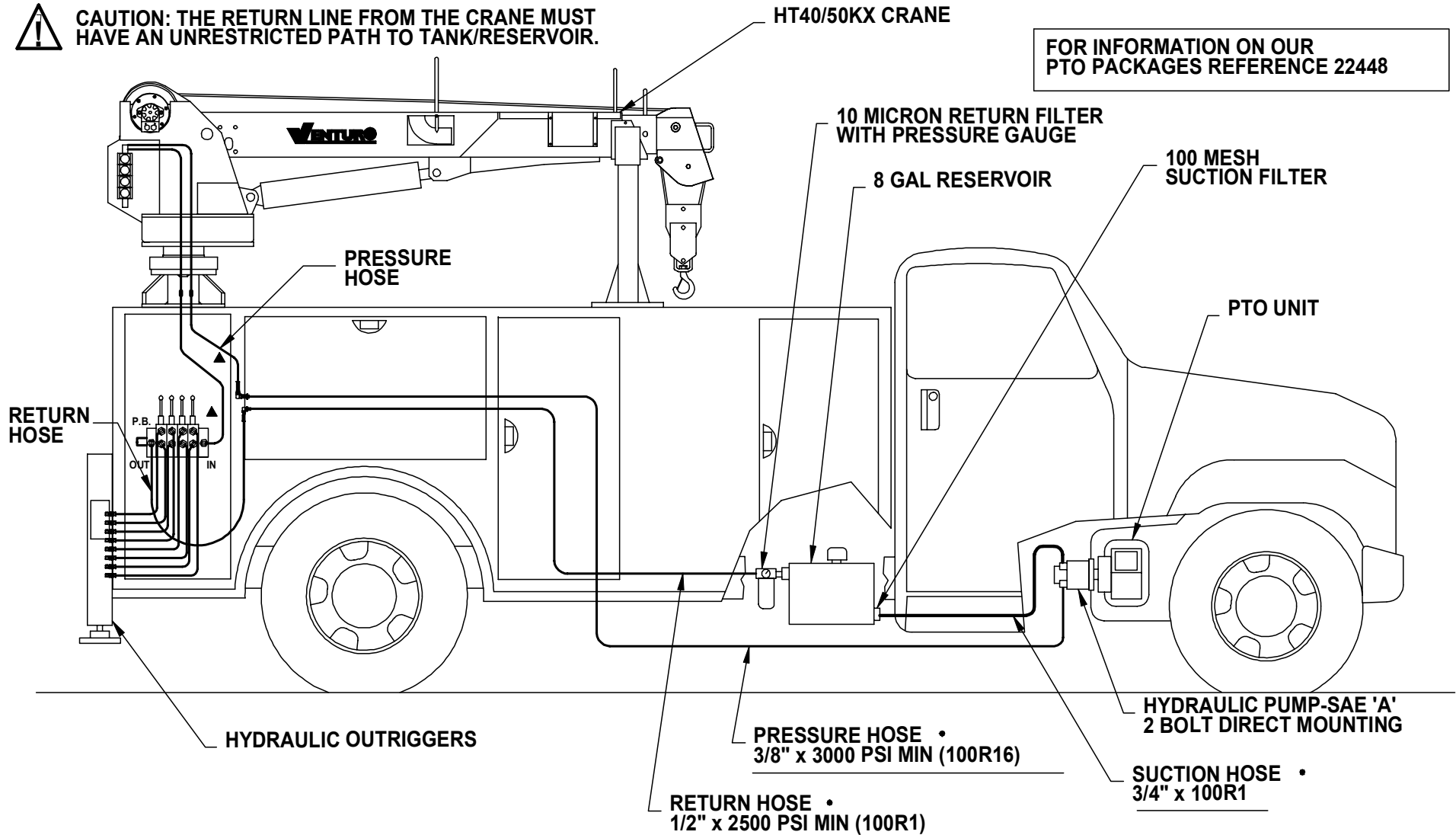

**HYDRAULIC REQUIREMENTS :**

- HT40KX STANDARD - 2.6 GPM @ 3000 PSI (19294-2.64 PTO PACKAGE)
- HT50KX STANDARD - 3.0 GPM @ 3000 PSI (19294-2.64 PTO PACKAGE)
- HT40KX PROPORTIONAL - 5.0 GPM @ 3000 PSI (19294-5.00 PTO PACKAGE)
- HT50KX PROPORTIONAL - 6.0 GPM @ 3000 PSI (19294-5.00 PTO PACKAGE)

SEE INSTALLATION INSTRUCTIONS 22344 (2 PAGES).

\*HOSES OR FITTINGS BETWEEN PUMP, RESERVOIR, AND CRANE NOT INCLUDED.



MANUFACTURING, INC.  
CINCINNATI, OHIO

TITLE  
**INSTALLATION DWG**

**PTO INST - HT40/50**

DATE  
**4-23-04C**

SUPERSEDES  
**11-22-02B**

SECTION  
**C200**

**22335**

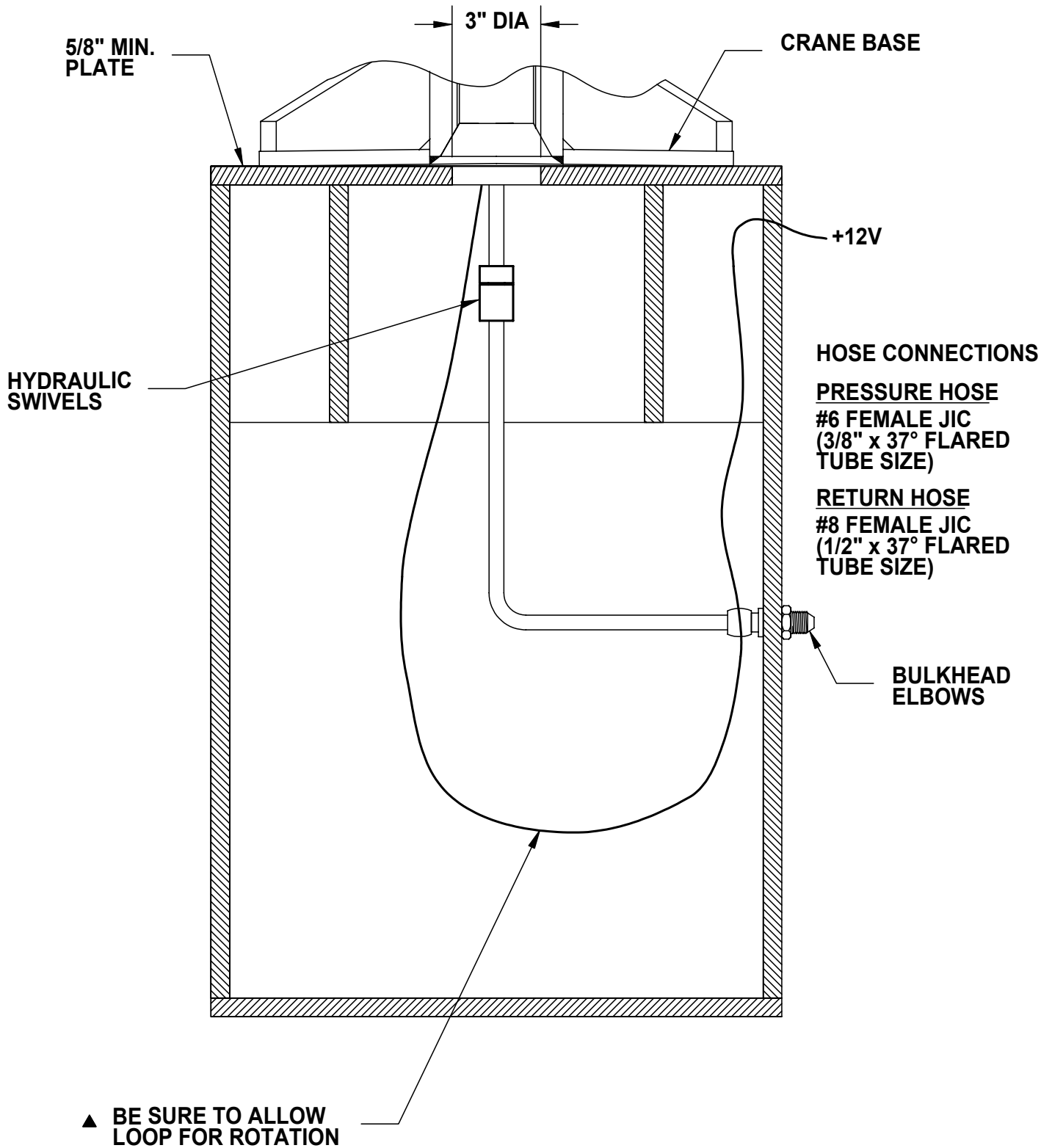

# 17830-XX PEDESTAL

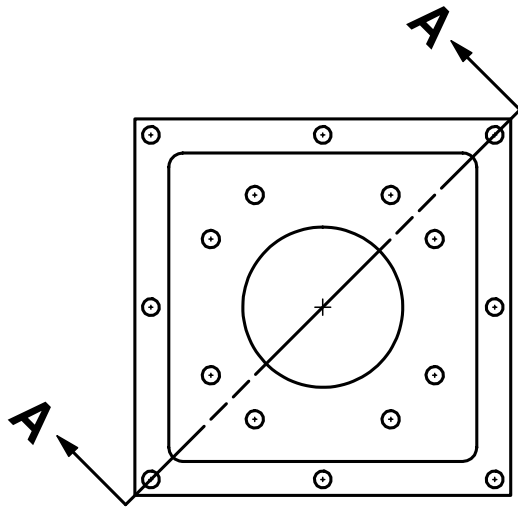

INSERT BULKHEAD FITTINGS (FURNISHED WITH HT40/50 CRANE) INTO THIS BRACKET AND ATTACH HOSES

19 1/4" (SQUARE)

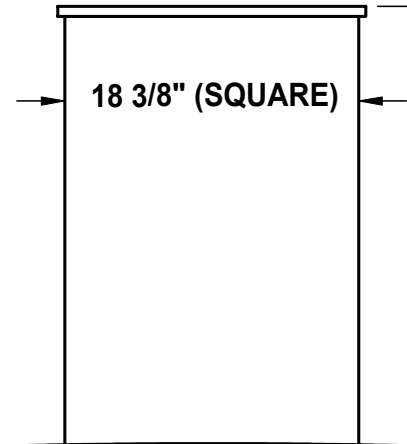

18 3/8" (SQUARE)

DASH NUMBER SPECIFIES HEIGHT

23 1/2"

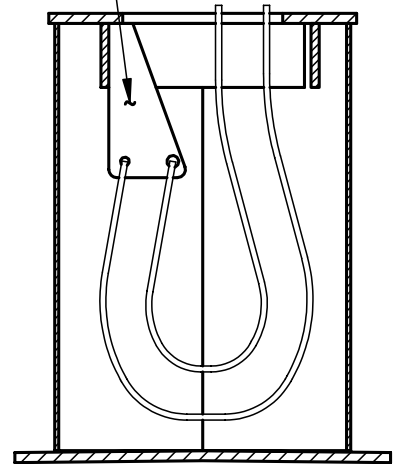

**SECTION A-A**

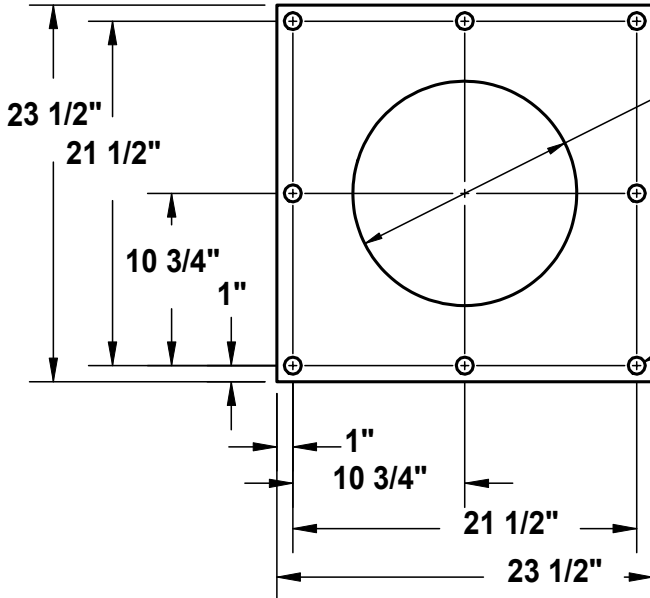

14" DIA

1 1/16" DIA HOLES FOR 1" GRADE 5 BOLTS -8 PLC



TITLE  
**MOUNTING DIMENSIONS**

DATE  
1-30-98B

SECTION  
C200

HT40/50KX CRANES

SUPERSEDES  
12-18-97A

**17831**

# WIRE ROPE INSTALLATION

STEP 1: INSERT WIRE ROPE END THROUGH ANTI-TWO-BLOCKWEIGHT.

STEP 2: INSERT WIRE ROPE END INTO POCKET OPENING AND THROUGH WEDGE POCKET.

CAUTION: IF THE WIRE ROPE IS NOT INSTALLED FOR THE CORRECT DRUM ROTATION, THE WINCH BRAKE VALVE WILL NOT HOLD THE LOAD.

NOTE: ON THE ET25K(X) A 7/16" HEX NUT WILL BE USED IN LIEU OF A WEDGE.

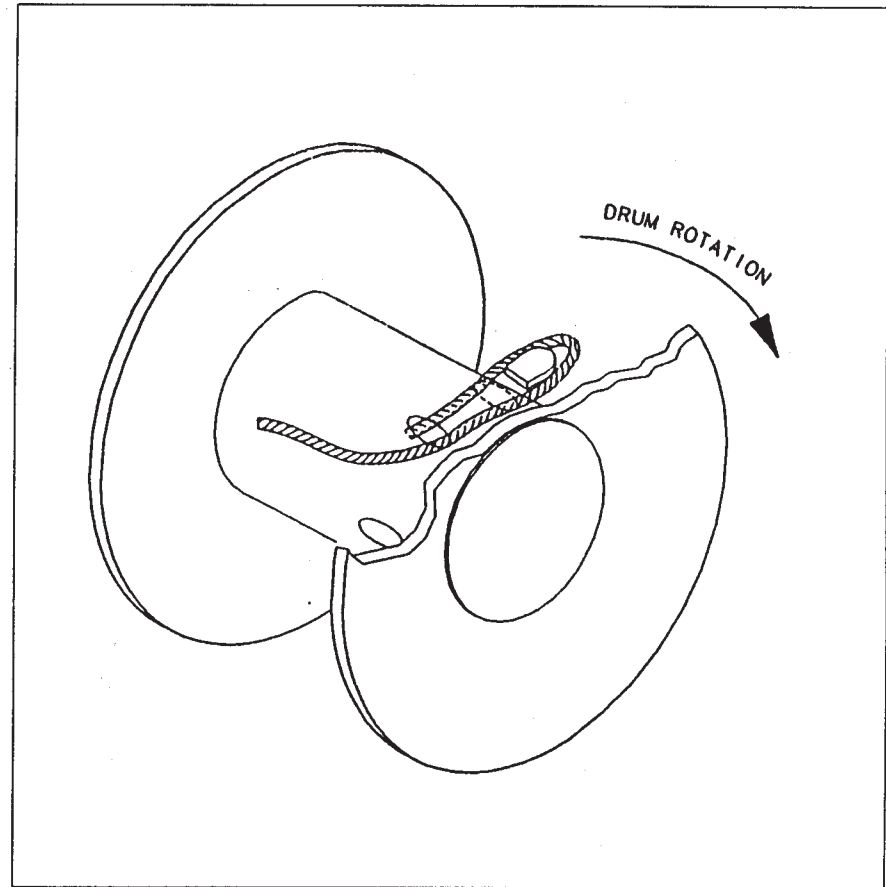

MANUFACTURING, INC.  
CINCINNATI, OHIO

TITLE  
WIRE ROPE INSTALLATION DRAWING

DATE  
11-22-02D

SECTION  
C200

ET/HT25K(X), HT40KX, HT50KX

SUPPERCEDES  
4-19-02C

22245

# ▲ REMTRON RADIO REMOTE CONTROL

▲ (20410, 20412 & 20414)

## INSTALLATION

### Mounting locations:

#### **On-crane mounting:**

For cranes without the "In-Compartment Controls" option, where the pendent/receiver connector plugs into a connector mounted on the crane housing, the receiver must be mounted directly on the crane as follows.

The **ET10KX** model without "In-Compartment Controls" requires the radio to be mounted on the rear of the crane housing with the cable and antenna facing downward as shown. Mounting the radio in this location will obscure several decals. Replacement decals (decals 15390A instructions, 15391B warning, 15392 warning) have been included in the retrofit kit and should be installed as close to the original locations as possible.

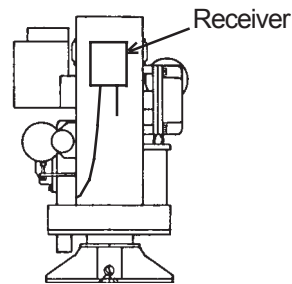

The **HT40/50KX** model without "In-Compartment Controls" requires the radio to be mounted on the right side of the crane's rear cover with the cable and antenna facing downward as shown.

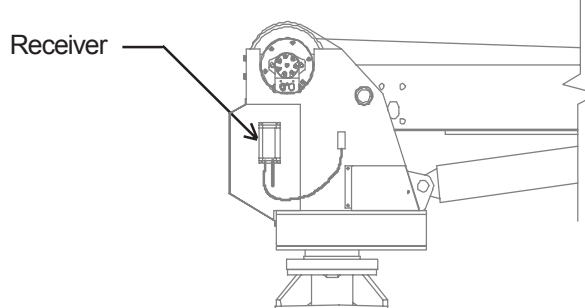

## **WARNING**

- The master disconnect (power) switch must be turned off when the crane is not in use! Leaving the power on when not in use may result in dangerous, unintentional activation of the crane functions.

**VENTURO**

MFG., INC.  
CINCINNATI, OHIO

TITLE  
**INSTALLATION DWG**

**RADIO REMOTE CONTROL**

DATE  
**7-25-03A**

SUPERCEDES  
**2-10-03**

SECTION  
**C200**

**20415A**

# ▲ REMTRON RADIO REMOTE CONTROL

## Remote antenna location:

Some applications may not provide adequate radio reception and therefore may require mounting the antenna in a remote location from the receiver. A remote antenna mounting kit (part number 20965) includes an extension cable and antenna mounting bracket. Note that a replacement antenna, part number 20966, is available but is not included in the remote antenna mounting kit.

- ▲ It is suggested that in applications requiring remote mounting of the antenna, that a high location be chosen such as on top of the truck body but in a location which is not vulnerable to damage. The remote antenna mounting location must provide line of sight access between the transmitter and receiver.

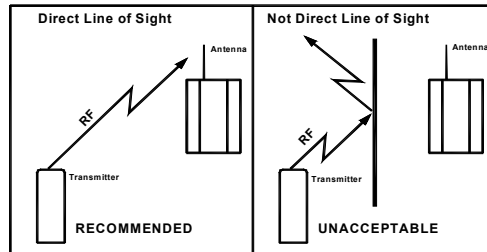

## In-compartment mounting:

For cranes with the “In-Compartment Controls” option the radio will be mounted inside the body compartment where the pendant/receiver connector is located. In order to provide full radio range the receiver must be mounted such that a line of sight path to the transmitter is provided, Note that the compartment door must remain open during operation to minimize interference with radio transmissions.

## Mounting instructions for all locations:

Locate the radio as described above and mark for mounting hardware making sure that both drilling and installation of the mounting hardware will not cause damage or interference with other components. Drill four .25 inch diameter clearance holes for the mounting hardware. Install the four #10x.75 long screws with flat washers through the mounting flanges on the receiver and through the mounting surface. Secure with the flat washers, lock washers and nuts provided. Note that one mounting flange has a metal ground tab. Star washers should be installed between the metal tab and hardware as well as between the mounting surface and hardware as shown. Install antenna and plug receiver connector into the socket to operate the crane.

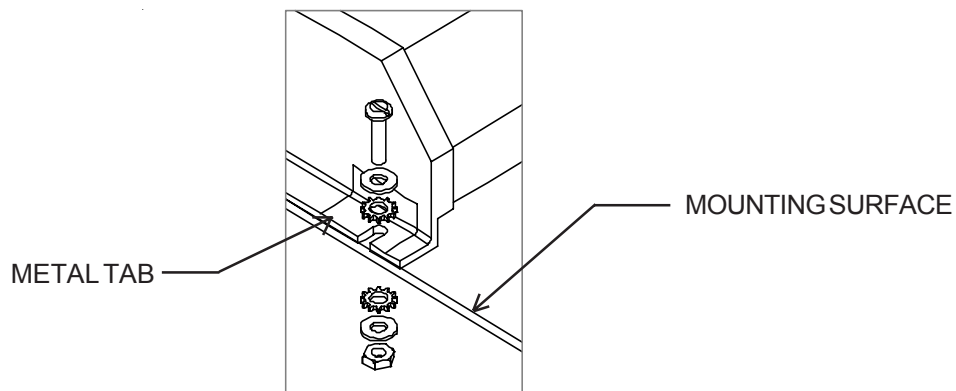

The transmitter is powered by a single 9V alkaline battery which may be replaced by removing the 4 screws from the transmitter housing and separating the 2 halves. Be sure to carefully align the two housing halves when reassembling the transmitter.



MFG., INC.  
CINCINNATI, OHIO

TITLE	INSTALLATION DWG
RADIO REMOTE CONTROL	

DATE	7-25-03A
SUPERCEDES	2-10-03

SECTION	C200
	20415B

# ▲ REMTRON RADIO REMOTE CONTROL

▲ (20410, 20412 & 20414)

## OPERATION

To operate the crane the receiver plug must be plugged into the socket and power must be switched on. The indicator on the receiver will light when it is powered and ready. The indicator will flash when the receiver is receiving a properly coded signal from the transmitter. The receiver requires "line of sight" access to the transmitter for full range operation. For cranes with in-compartment controls the compartment door must be left open during operation of the crane in order to avoid obstructing the radio signal.



## **WARNING**

- **The receiver connector must be unplugged from the socket and the master disconnect (power) switch must be turned off when the crane is not in use! Leaving the receiver connected and the power on when not in use may result in dangerous, unintentional activation of the crane functions.**

For safety reasons the receiver will only function when it recognizes coded transmissions which match that of the intended transmitter. In the event that the receiver fails to recognize commands from the intended transmitter or when initially using a replacement transmitter the receiver must "learn" the transmission code of the transmitter. "Learning" a new transmission code is accomplished by depressing any button on the transmitter then depressing the "learn" button on the receiver, next to the antenna, until the light on the receiver begins to flash. Once the receiver light begins to flash release the learn button and then the transmitter button. The receiver will now recognize transmissions from the "learned" transmitter.

The transmitter is powered by a single 9V alkaline battery which may be replaced by removing the 4 screws from the transmitter housing and separating the 2 halves. Be sure to carefully align the two housing halves when reassembling the transmitter.



MFG., INC.  
CINCINNATI, OHIO

TITLE

INSTALLATION DWG.

DATE

7-25-03A

SECTION

C200

RADIO REMOTE CONTROL

SUPERCEDES

2-11-03

**20416**



# **SECTION 300**

**MAINTENANCE**

**&**

**SERVICE**

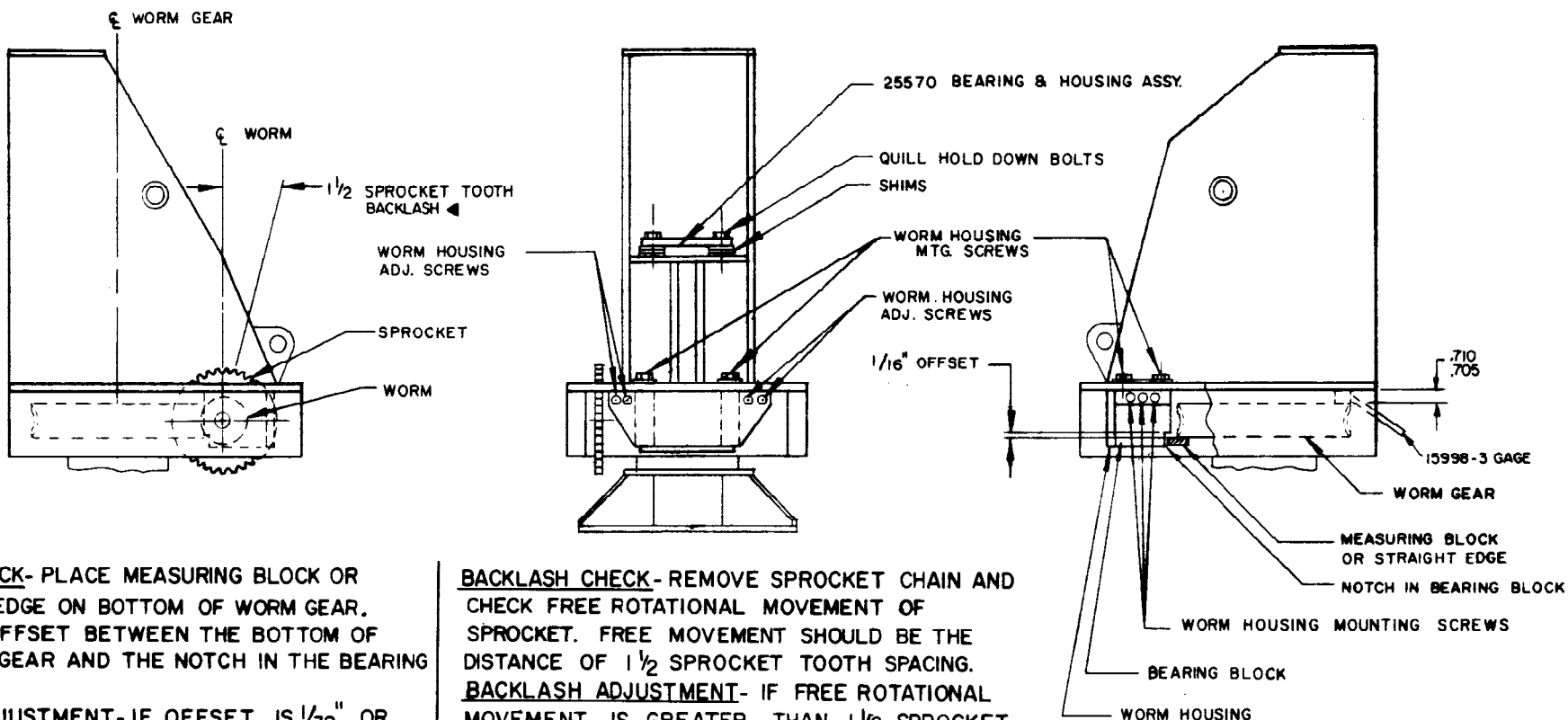

**HEIGHT CHECK-** PLACE MEASURING BLOCK OR STRAIGHT EDGE ON BOTTOM OF WORM GEAR. MEASURE OFFSET BETWEEN THE BOTTOM OF THE WORM GEAR AND THE NOTCH IN THE BEARING BLOCK.

**HEIGHT ADJUSTMENT-** IF OFFSET IS  $\frac{1}{32}$ " OR LESS, THEN HEIGHT ADJUSTMENT IS REQUIRED. **ADJUSTMENT METHOD-** LOOSEN QUILL HOLD DOWN BOLTS (2 PLACES). REMOVE SHIMS TO INCREASE OFFSET TO  $\frac{1}{16}$ ".

**ALTERNATE HEIGHT ADJUSTMENT METHOD**  
USE 15998-3 GAGE TO SET DISTANCE BETWEEN GEAR & HOUSING TO  $\frac{.710}{.705}$ .

**NOTE:** BEFORE CHECKING BACKLASH, CHECK WORM END PLAY AS DESCRIBED ON DRAWING 14553 AND ADJUST END PLAY IF NECESSARY.

**BACKLASH CHECK-** REMOVE SPROCKET CHAIN AND CHECK FREE ROTATIONAL MOVEMENT OF SPROCKET. FREE MOVEMENT SHOULD BE THE DISTANCE OF  $\frac{1}{2}$  SPROCKET TOOTH SPACING.

**BACKLASH ADJUSTMENT-** IF FREE ROTATIONAL MOVEMENT IS GREATER THAN  $\frac{1}{2}$  SPROCKET TOOTH, THEN THE DISTANCE BETWEEN THE CENTERLINES OF THE WORM GEAR AND THE WORM SHOULD BE DECREASED. IF THE FREE MOVEMENT IS LESS THAN  $\frac{1}{2}$  TOOTH, THEN CENTERLINE DISTANCE SHOULD BE INCREASED.

**ADJUSTMENT METHOD-** LOOSEN WORM HOUSING MOUNTING SCREWS (7 PLACES). MOVE WORM HOUSING TOWARDS, OR AWAY FROM CENTERLINE OF WORM GEAR WITH THE WORM HOUSING ADJUSTMENT SCREWS. TIGHTEN WORM HOUSING, AND RECHECK BACKLASH. THE FREE MOVEMENT SHOULD BE EQUAL TO  $\frac{1}{2}$  SPROCKET TOOTH SPACING.

**ADJUSTMENT OF WORM HEIGHT AND BACKLASH**



TITLE	DATE	SECTION
ASSEMBLY & SERVICE INST.	1-19-00D	C320
ET 20,000, ET20K(X), ET25K(X), HT25K(X), HT40/50KX ▲	SUPERCEDES 8-10-98C	14544

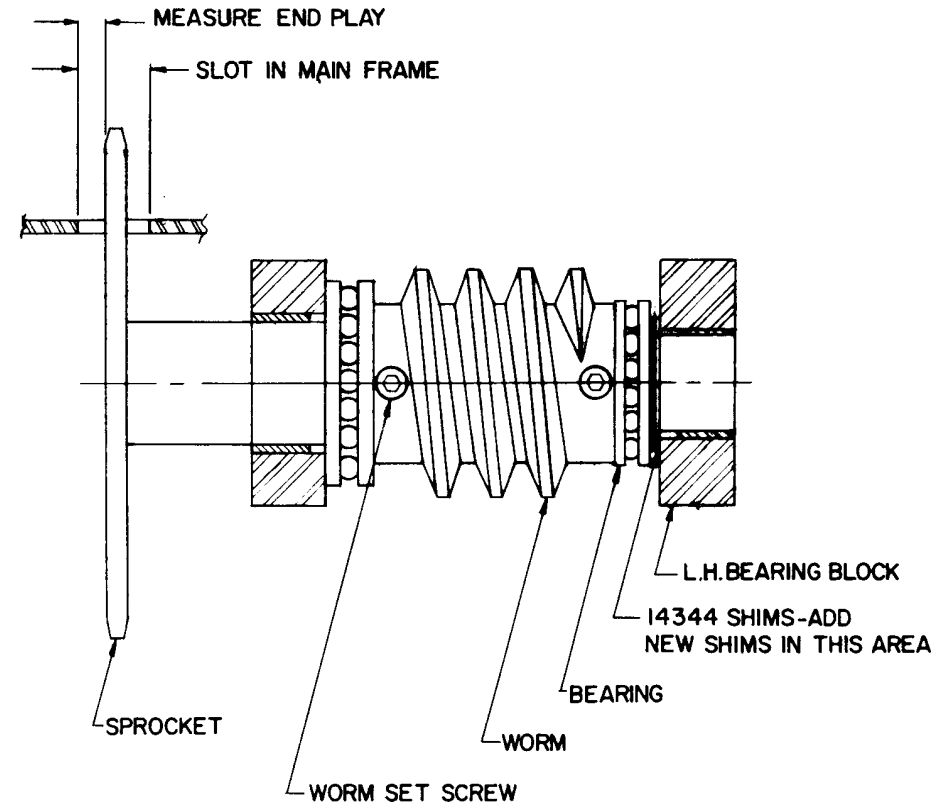

**END PLAY CHECK** - REMOVE LOWER COVER & SIDE COVER. TO CHECK WORM END PLAY, APPLY TORQUE TO CRANE BY PUSHING IN OPPOSITE DIRECTIONS ON BOOM. IF END PLAY IS MORE THAN .005" THEN ADJUSTMENT IS REQUIRED. MEASURE END PLAY WITH CALIPERS BETWEEN OUTSIDE FACE OF SPROCKET & SPROCKET SLOT IN MAIN FRAME.

**END PLAY ADJUSTMENT** - REMOVE DRIVE CHAIN, THEN REMOVE WORM & WORM HOUSING AS ONE UNIT. LOOSEN WORM SET SCREWS & PUSH WORM SHAFT OUT OF L.H. BEARING BLOCK. PLACE ADDITIONAL SHIMS (P/N 14344) AS DETERMINED BY END PLAY CHECK. (NOTE: THE SHIM ARE .005" THK.) PUSH WORM SHAFT BACK IN L.H. BEARING BLOCK & TIGHTEN WORM SET SCREWS. INSTALL WORM HOUSING ASSEMBLY TO MAIN FRAME. ADJUST BACKLASH PER DWG. 14544. REPLACE DRIVE CHAIN & COVERS.

ADJUSTMENT OF ROTATION WORM END PLAY



MANUFACTURING, INC.  
CINCINNATI, OHIO

TITLE  
**ASSEMBLY & SERVICE INST.**

**ET 20,000 CRANE**

DATE  
**8-10-98B**

SUPERCEDES  
**3-10-82A**

SECTION  
**C320**

**14553**

# SECTION 400

## PARTS



REPLACEMENT PARTS LIST - REF 22517 ▲  
 REPLACEMENT PARTS LIST - FULL POWER BOOM 22572  
 REPLACEMENT FASTENERS LIST REF 22518 ▲

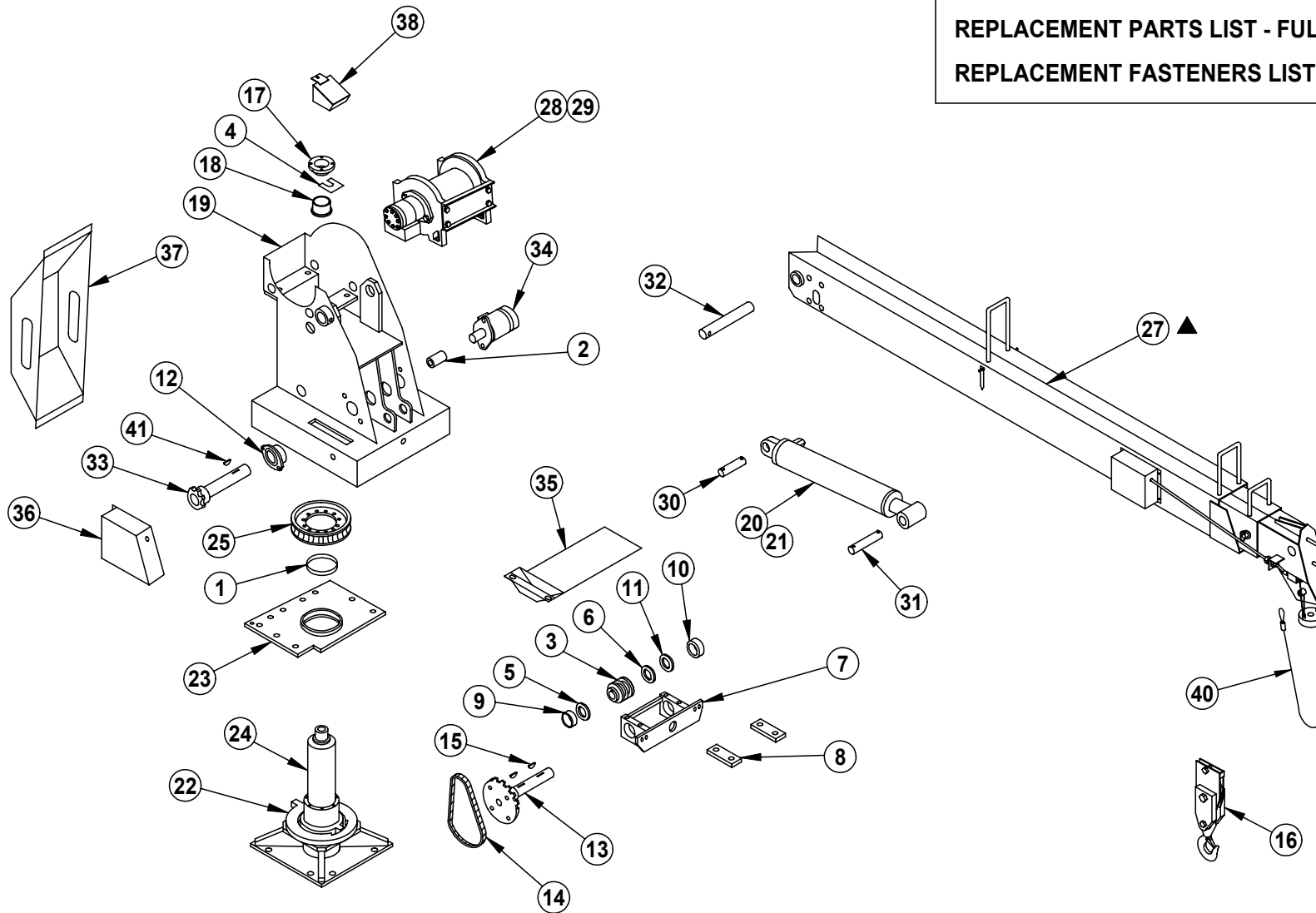

ITEM #	PART #	DESCRIPTION	ITEM #	PART #	DESCRIPTION
1	22017	LOWER BEARING - 8" OD x 1.5" LONG	41	26404	WOODRUFF KEY - 1/4" x 1" (MODIFIED)
2	14084	COUPLING	42	-	-
3	14142-4	WORM - SINGLE THREAD RH	43	-	-
4	14159	SHIM - 1-1/2" SQ x .015", .042", .105"	44	-	-
5	14191-1	BALL THRUST BEARING - 2" ID x 3-11/32" OD	45	-	-
6	14191-2	BALL THRUST BEARING - 1-1/2" ID x 2-19/32" OD	46	-	-
7	14242	HOUSING, WORM GEAR	47	-	-
8	14245	WASHER PLATE	48	-	-
9	14341-1	BUSHING - 2.003" ID x 2.252" OD x 15/16" LONG	49	-	-
10	14341-2	BUSHING - 1.503" ID x 1.752" OD x 1" LONG	50	-	-
11	14344	SHIM WASHER - 1-1/2" ID x 2-1/8" OD x .005", .015", .031" THK	51	22494	FIELD SERVICE LABEL KIT - HT40KX NON-PROP.
12	22468	HD STEEL FLANGE MOUNTED BALL BEARING - 1" BORE	52	22494-1	FIELD SERVICE LABEL KIT - HT40KX PROPORTIONAL
13	14384	SPROCKET AND SHAFT ASSEMBLY (40T SPROCKET)	53	22495	FIELD SERVICE LABEL KIT - HT50KX NON-PROP.
14	14481	ROTATION DRIVE CHAIN	54	22495-1	FIELD SERVICE LABEL KIT - HT50KX PROPORTIONAL
15	15245	WOODRUFF KEY - 5/16" x 1-1/8" (MODIFIED)	55	-	-
16	17770	HEADACHE BALL ASSEMBLY	56	-	-
17	18068	BEARING HOUSING - 1-1/8" LONG	57	-	-
18	18069	FLANGED BEARING - 2" BORE x 3" OD FLANGE	58	-	-
19	22006	WELDED HOUSING ASSEMBLY	59	-	-
20	22021-1	ELEV. CYL. 4.5" BORE x 2" ROD x 19.63" STROKE	60	-	-
21	22022-1	ELEV. CYL. 5" BORE x 2" ROD x 19.63" STROKE	61	-	-
22	22024	STOPRING - ROTATION	62	-	-
23	22026	LOWER BEARING PLATE ASSEMBLY	63	-	-
24	22030	QUILL ASSEMBLY	64	-	-
25	22041	WORM GEAR - ROTATION	65	-	-
26	24524	BOOM ASSEMBLY - HT40/50KX	66	-	-
27	▲ 24550	FULL POWER BOOM ASSEMBLY - HT40/50KXX	67	-	-
28	22266	WINCH - 3000 LB (SINGLE LINE) - HT40KX	68	-	-
29	22268	WINCH - 4000 LB (SINGLE LINE) - HT50KX	69	-	-
30	22274	PIVOT PIN, CYL TAIL - 1-1/2" OD x 2-13/16" LONG	70	-	-
31	22275	PIVOT PIN, CYL ROD - 1-1/2" OD x 6-7/8" LONG	71	-	-
32	22290	PIVOT PIN, BOOM - 1-3/4" OD x 12-1/2" LONG	72	-	-
33	22291	SPROCKET AND SHAFT ASSEMBLY (10T SPROCKET)	73	-	-
34	22294	HYDRAULIC MOTOR - ROTATION	74	-	-
35	22298	LOWER COVER	75	-	-
36	22303	CHAIN COVER	76	-	-
37	22322	VALVE COVER ASSEMBLY	77	-	-
38	22387	RAIN COVER - QUILL	78	-	-
39	-	-	79	-	-
40	17094-3/8-100	WIRE ROPE ASSEMBLY - 3/8" x 100 FT	80	-	-
		 ITEM NOT SHOWN ON REPLACEMENT PARTS DRAWING  REPLACEMENT PARTS DWG REF 22346			



MANUFACTURING, INC.  
CINCINNATI, OHIO

TITLE  
**REPLACEMENT PARTS**

DATE  
**3-4-03C**

SECTION  
**C400**

**HT40KX, HT50KX**

SUPERCEDES  
**10-29-01B**

**22517**

## FASTENER LIST FOR HT40/50KX

PART NUMBER	DESCRIPTION	QTY	LOCATION/FUNCTION
14353 ▲ !HHCS05013150 !LWSH-050 18927 !LWSH-050-HC	COIL PIN - 1/2" x 1-1/2" HHCS - 1/2"-13 x 1-1/2" LOCK WASHER - 1/2" CAPSCREW - MODIFIED LOCK WASHER - 1/2" HI COLLAR	10 10 10 12 12	BASE PLATE BASE PLATE BASE PLATE BULL GEAR BULL GEAR
!HHCS06311175 !LWSH-063 !SHCS05020125 25593 !HHCS02520063-5	HHCS - 5/8"-11 x 1-3/4" LOCK WASHER - 5/8" SHCS - 1/2"-20 x 1-1/4" SET SCREW - FLAT FACE 1/2"-20 x 1" HHCS 1/4"-20 x 5/8"	4 4 2 5 7	WORMHOUSING WORMHOUSING WORMHOUSING WORMHOUSING LOWERCHAIN COVER
!LWSH-025 !UNUT15195-1420 !HHCS02520063-5 !HHCS02520375 !HNUT-02520	LOCK WASHER - 1/4" FASTENER, U-NUT, 1/4"-20 HHCS 1/4"-20 x 5/8" HHCS - 1/4"-20 x 3-3/4" HEX NUT - 1/4"-20	7 7 2 1 1	LOWERCHAIN COVER LOWERCHAIN COVER SIDE CHAIN COVER SIDE CHAIN COVER SIDE CHAIN COVER
!LWSH-025 !HHCS02520063-5 !LWSH-025 !SHCS03816350 !HNUT-03816	LOCK WASHER - 1/4" HHCS - 1/4"-20 x 5/8" LOCK WASHER - 1/4" SHCS - 3/8"-16 x 3-1/2" HEX NUT - 3/8"-16	3 4 4 2 2	SIDE CHAIN COVER VALVE BACK COVER VALVE BACK COVER VALVE BANK VALVE BANK
!LWSH-038-HC 12534-4 !RPIN-025200 !HHCS03816125 !HWSH-038SAE	LOCK WASHER - 3/8" HI COLLAR BUSHING - 1/2" I.D. x 7/8" O.D. x 14 GA ROLL PIN - 1/4" DIA x 2" LONG HHCS - 3/8"-16 x 1-1/4" HEX WASHER - SAE 3/8"	2 4 4 2 2	VALVE BANK VALVE BANK ELEVATION CYLINDER PINS ROTATION SHAFT BEARING ROTATION SHAFT BEARING
!LWSH-038 !HNUT-03816 !HHCS03118100-5 !HNUT-03118 !HHCS05013175	LOCK WASHER - 3/8" HEX NUT - 3/8"-16 HHCS - 5/16"-18 x 1-1/2" HEX NUT - 5/16"-18 HHCS - 1/2"-13 x 1-3/4"	2 2 1 1 2	ROTATION SHAFT BEARING ROTATION SHAFT BEARING SUPPORT-ROTATION BEARING SUPPORT-ROTATION BEARING ROTATION MOTOR
!LWSH-050-STAR !LWSH-050 !HNUT-05013 !HHCS05013225 !LWSH-050	LOCK WASHER - 1/2" STAR LOCK WASHER - 1/2" HEX NUT - 1/2"-13 HHCS - 1/2"-13 x 2-1/4" LOCK WASHER - 1/2"	2 2 2 4 4	ROTATION MOTOR ROTATION MOTOR ROTATION MOTOR WINCH WINCH
!FWSH-050 !HNUT-05013 19269 !HHCS02520063-5 !LWSH-025	FLAT WASHER - 1/2" HEX NUT - 1/2"-13 CLAMP, CABLE - 1/4" HHCS - 1/4"-20 x 5/8" LOCK WASHER - 1/4"	4 4 1 1 1	WINCH WINCH PRESSURE SWITCH HARNESS PRESSURE SWITCH HARNESS PRESSURE SWITCH HARNESS
!HHCS05013125-5 !LWSH-050 !HHCS03816100 !FWSH-038 !LWSH-038	HHCS - 1/2"-13 x 1-1/4" LOCK WASHER - 1/2" HHCS - 3/8"-16 x 1" FLAT WASHER - 3/8" LOCK WASHER - 3/8"	4 4 4 4 4	UPPER BEARING UPPER BEARING WINCH (BACK SIDE) WINCH (BACK SIDE) WINCH (BACK SIDE)
19271-2 !HHCS05013300 RL-644 !LNUT-05013 !HHCS02520075-5	PLASTIC PLUG - 2-1/8" DIA HHCS - 1/2"-13 x 3" INSULATING PLUG - 1" LOCK NUT - 1/2"-13 NYLON INSERT HHCS - 1/4"-20 x 3/4"	2 1 4 1 1	WINCH ACCESS HOLES BOOM PIVOT PIN LOWER HOUSING BOOM PIVOT PIN GROUND SCREW
!PHCS#1024050 !LWSH-#10 !PHCS#0632100 !PHCS03816050 -	PHCS - #10-24 x 1/2" LOCK WASHER - #10 PHCS - 6-32 x 1" PHCS - 3/8"-16 x 1/2" -	2 2 2 1 -	CIRCUIT BREAKER CIRCUIT BREAKER TERMINAL BLOCK COUPLING FOR MASTER BYPASS VALVE -

REPLACEMENT PARTS DWG REF 22346

SERIAL NO. 84030 & UP  
SERIAL NO. 85030 & UP



MFG., INC.  
CINCINNATI, OHIO

TITLE	DATE	SECTION
REPL. FASTENERS LIST	7-17-00B	C400
HT40KX, HT50KX	SUPPERCEDES 6-8-98A	22518

# 24550 BOOM PARTS DRAWING

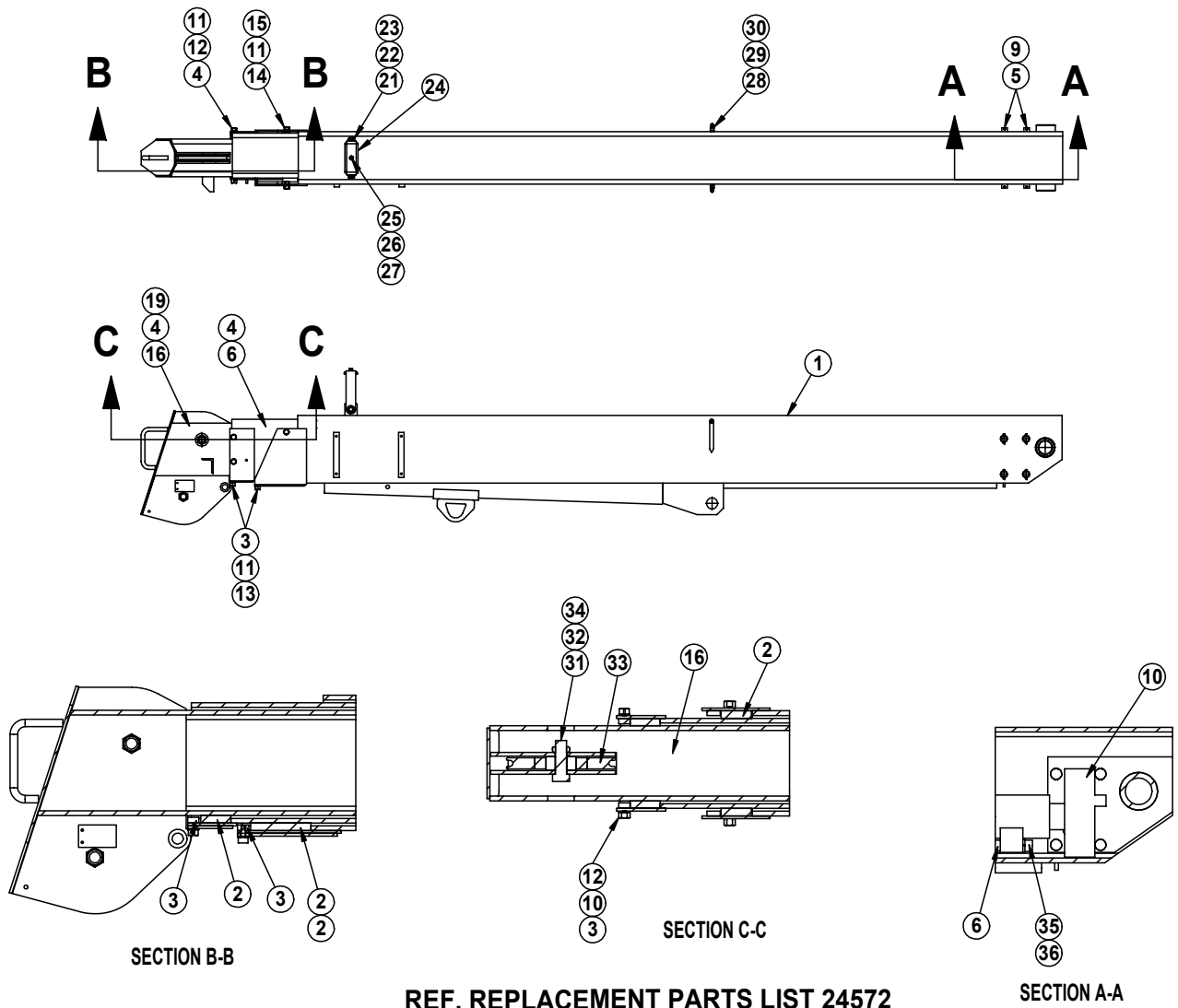

REF. REPLACEMENT PARTS LIST 24572

<b>VENTURO</b> MANUFACTURING, INC. CINCINNATI, OHIO	TITLE	DATE	SECTION
	24550 BOOM PARTS DRAWING	3-4-03	C400
HT40/50KXX	SUPERSEDES	24571	
	-		



ITEM	QTY	MANUAL EXTENSION		PART NO.	DESCRIPTION	ITEM	QTY	MANUAL EXTENSION		PART NO.	DESCRIPTION
		+	+					+	+		
19	2	+	+	18957	BEARING PAD - SIDE FRONT	-	-				
18	1	+	+	24568	PIN - CYLINDER	38	1	+	+	24566	* EXTENSION CYLINDER
17	2		+	24558	PIN BLOCK	38	1	+	+	22032-2	* EXTENSION CYLINDER
16	1		+	24556-2	TERTIARY BOOM TUBE ASSEMBLY	37	8	+	+	!CAC06318100	COUNTERSUNK ALLEN HEAD CAP SCREW 5/8-18 X 1" LONG
16	1	+		24556-1	TERTIARY BOOM TUBE ASSEMBLY	36	2	+	+	!LOWSH-050	LOCK WASHER - 1/2-13
15	2	+	+	!HNUT-03816	HEX NUT - 3/8-16	35	2	+	+	!SHCS05013250	SOCKET HEAD CAP SCREW - 1/2-13 X 2-1/2" LONG
14	2	+	+	!HHCS03816038	NEX HEAD CAP SCREW - 3/8-16 X 3/8" LONG	34	2	+	+	!JNUT-07510N	NYLON LOCK - JAMNUT - 3/4-10
13	4	+	+	!HHCS03816075	HEX HEAD CAP SCREW - 3/8-16 X 3/4" LONG	33	2	+	+	23928	BOOM SHEAVE WITH BUSHING
12	4	+	+	!HHCS03816063	HEX HEAD CAP SCREW - 3/8-16 X 5/8" LONG	32	2	+	+	17059-1	SHEAVE AXLE
11	10	+	+	!LWSH-038	LOCK WASHER - 3/8"	31	1	+	+	23929	SPACER - 23927 & 23928 POLY SHEAVES
10	1	+	+	24566	EXTENSION CYLINDER	30	2	+	+	!ANUT-02520S	ACORN NUT - 1/4-20 STAINLESS
9	8	+	+	!RPIN-019125	ROLL PIN 3/16" DIA X 1-1/4" LONG	29	2	+	+	13459-2	BOOM ARROW 4-7/16" LONG
8	4	+	+	24519	SIDE, REAR BEARING	28	2	+	+	22490	SPACER, BOOM ARROW 1/2" O.D.
7	1	+	+	24559	NUT BAR	27	1	+	+	!HNUT-02520	HEX NUT 1/4-20
6	1		+	24554-2	SECONDARY BOOM TUBE ASSEMBLY	26	1	+	+	!LWSH-025	LOCK WASHER - 1/4"
6	1	+		24554-1	SECONDARY BOOM TUBE ASSEMBLY	25	1	+	+	!HHCS02520075	HEX HEAD CAP SCREW - 1/4-20 X 3/4" LONG
5	4	+	+	22239	THRUST PIN - 3/4 X 8	24	1	+	+	19881	CABLE GUIDE WEAR STRIP
4	-	+	+	-	-	23	2	+	+	!JNUT-05013N	1/2-13 NYLON INSERT JAM NUT
3	4	+	+	24522	LOWER FRONT NUTBAR	22	1	+	+	!FWSH-050	FLAT WASHER - 1/2"
2	9	+	+	24562	BEARING	21	2	+	+	!HHCS05013100	HEX HEAD CAP SCREW - 1/2-13NC X 1" LONG
1	1	+	+	24552	PRIMARY BOOM FINAL ASSEMBLY	20	1	+	+	19880	CABLE GUIDE STRUCTURE

\* ITEMS NOT SHOWN ON DWG. 24571

REF. REPLACEMENT DRAWING NO. 24571



MANUFACTURING, INC.  
CINCINNATI, OHIO

TITLE

24550 BOOM REPLACEMENT PARTS LIST

DATE

1-29-04A

SECTION

C400

HT40/50KXX

SUPERSEDES

3-4-03

24572

REPLACEMENT PARTS LIST REF 22361

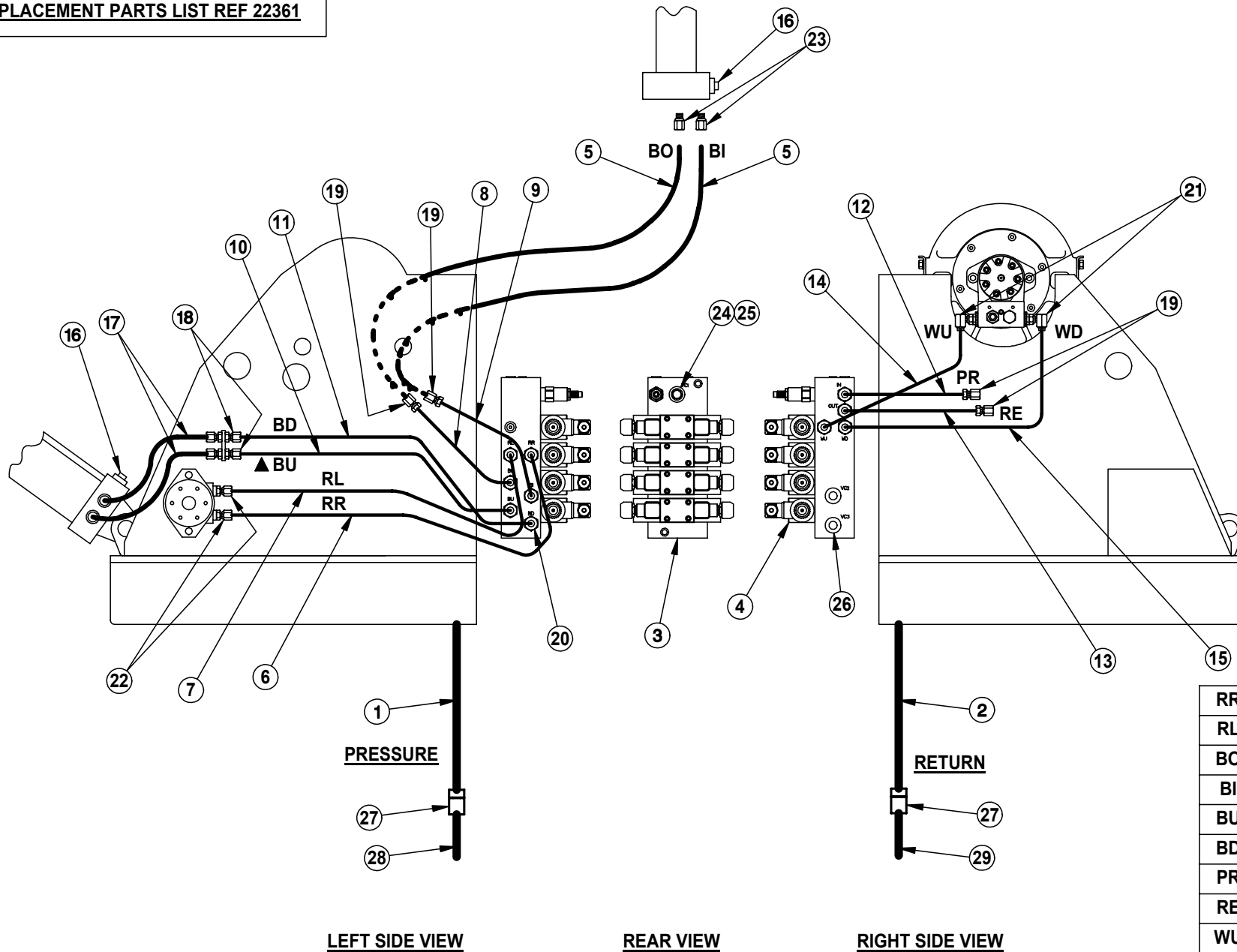

## HYDRAULIC SYSTEM COMPONENTS - HT40/50KX CRANES REPLACEMENT PARTS LIST

ITEM	PART NUMBER	DESCRIPTION
1	20685	PRESSURE HOSE - HOUSING SIDE
2	20686	RETURN HOSE - HOUSING SIDE
3	22501	VALVE BANK - HT40KX, HT50KX
4	22523	VALVE ASSEMBLY (VALVE BLOCK, VALVE, COIL, & HARDWARE)
	22362	COIL ONLY
5	22363	EXTENSION CYLINDER HOSE
6	22505	HYD TUBING - ROTATION RIGHT
7	22506	HYD TUBING - ROTATION LEFT
8	22507	HYD TUBING - BOOM OUT
9	22508	HYD TUBING - BOOM IN
10	22509	HYD TUBING - BOOM UP
11	22510	HYD TUBING - BOOM DOWN
12	22511	HYD TUBING - PRESSURE
13	22512	HYD TUBING - RETURN
14	22513	HYD TUBING - WINCH UP
15	22514	HYD TUBING - WINCH DOWN
16	19247	COUNTERBALANCE VALVE (ELEVATION & EXTENSION CYLINDERS)
17	22382	ELEV CYLINDER HOSE - 22" x 6MBX x 6FJX
18	HBLK6MJ-6MJ	HYD BULKHEAD
19	HBLK6MJ-6MJ-90	HYD BULKHEAD UNION ELBOW WITH LOCK NUT - 6MJ x 90°
20	HNPL6MJ-6MO	HYD NIPPLE
21	HELB8MO-6MJ-90	HYD ELBOW
22	HNPL10MO-6MJ	HYD NIPPLE
23	HRDB6MO-4FP	HYDRAULIC BUSHING - 6MO-4FP
24	22502	PROPORTIONAL VALVE
25	22503	MASTER BYPASS VALVE AND COIL
26	22312-X.XX	PRIORITY FLOW CART (X.XX REFER TO CHART BELOW)
27	20684	LIVE CONTINUOUS HYDRAULIC SWIVEL
28	20687	PRESSURE HOSE - COMPARTMENT SIDE
30	20688	RETURN HOSE - COMPARTMENT SIDE

REPLACEMENT PARTS DWG REF 20699

STANDARD  
(NON-PROP)

PROPORTIONAL

HT40	EXTENSION	1.25	2.25
	ELEVATION	1.75	4.00
HT50	EXTENSION	1.25	2.25
	ELEVATION	2.25	4.00

SERIAL NO. 84030 & UP  
SERIAL NO. 85030 & UP



MFG., INC.  
CINCINNATI, OHIO

TITLE  
**REPL. PARTS LIST**

**HT40/50KX**

DATE  
**10-10-02**

SUPERCEDES  
-

SECTION  
**C400**

**20930**

01025-14\*25FT  
FROM BATTERY  
+12VDC

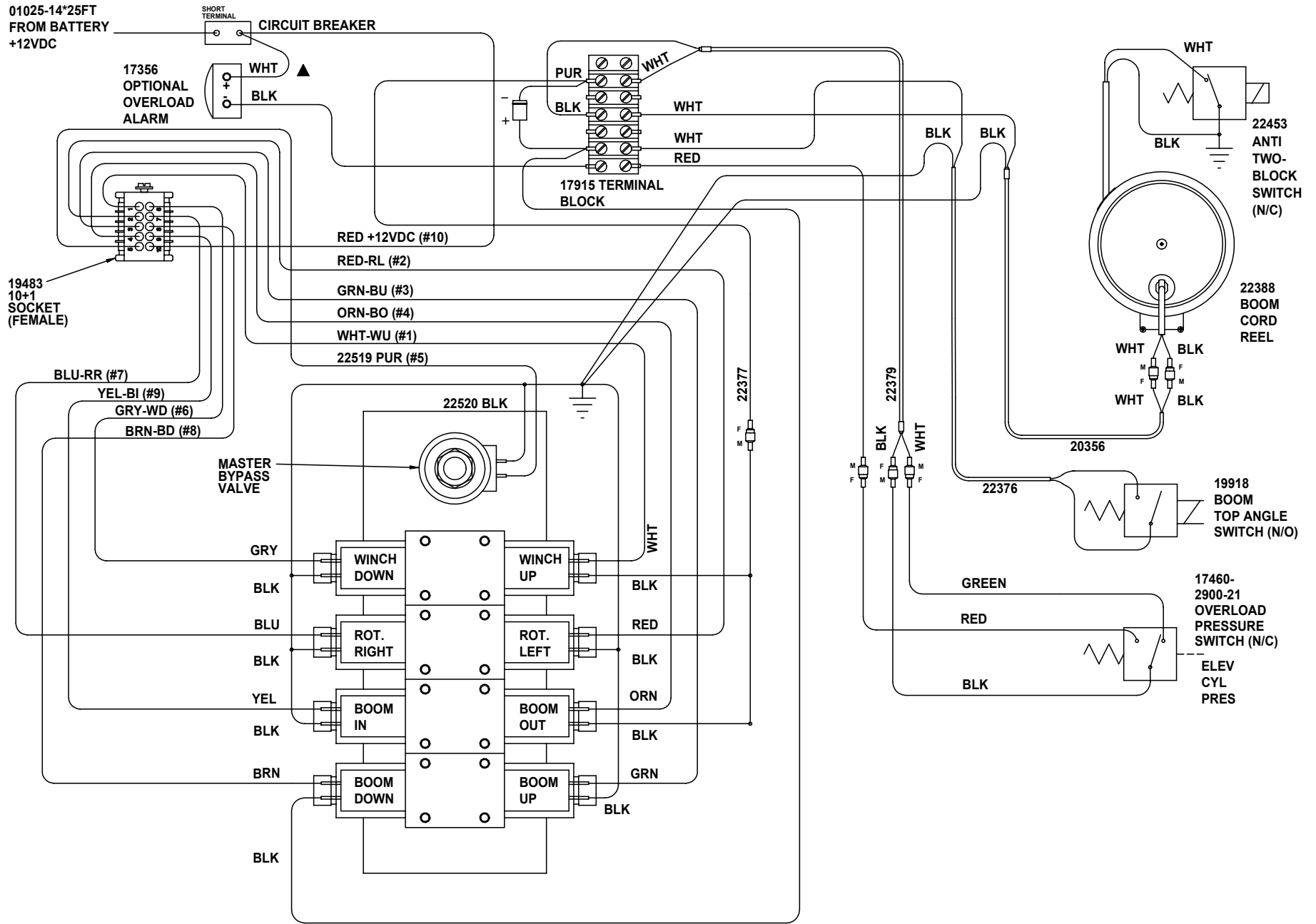

TITLE  
**WIRING DIAGRAM - MANUAL BYPASS**

DATE  
**10-7-03G**

SECTION  
**C400**

**HT40KX, HT50KX - 4 FUNCTION STD**

SUPERSEDES  
**12-17-02F**

**22484**

# NON-PROPORTIONAL IN-COMPARTMENT CONTROLS

FROM "IN COMPARTMENT"  
SOCKET

20074

THESE WIRES CONNECTED  
TO VALVE BANK

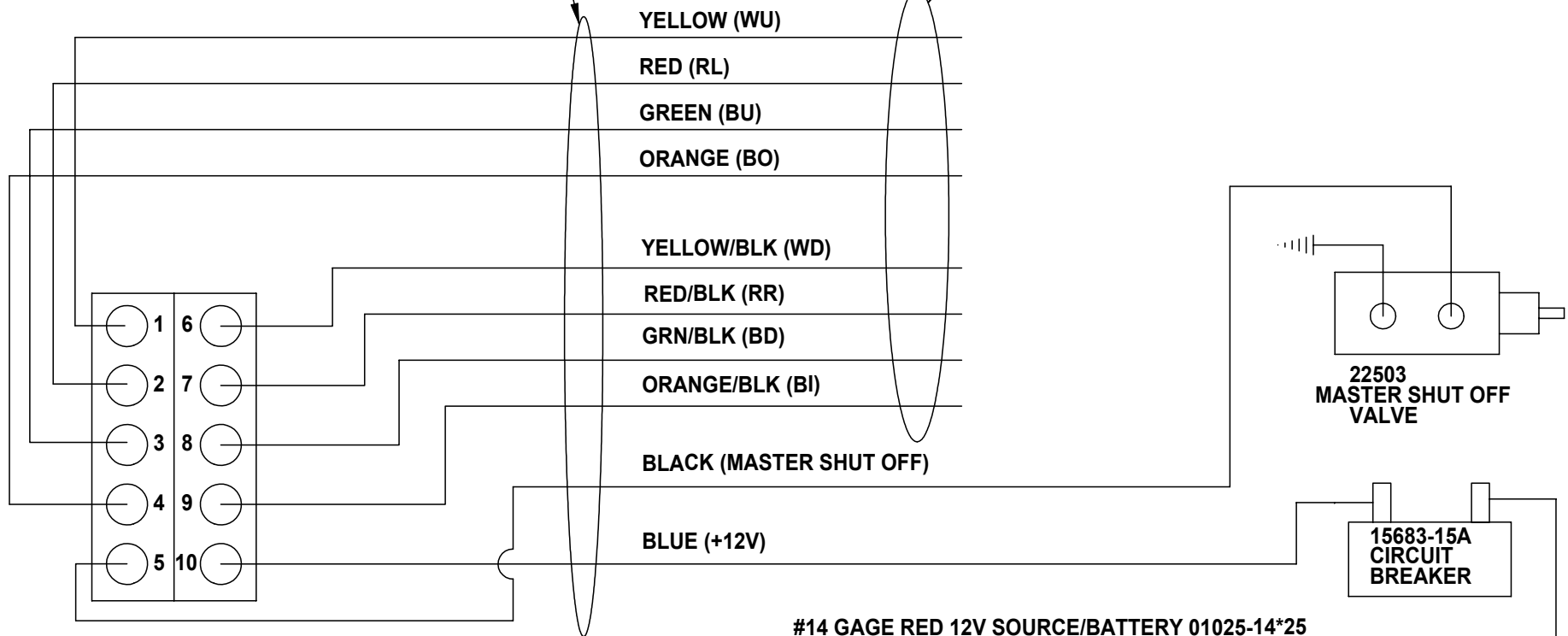

19483  
10+1 SOCKET

CUT RED WIRE AND INSTALL  
MASTER TOGGLE SWITCH  
AT SWITCH BRACKET

#14 GAGE RED 12V SOURCE/BATTERY 01025-14\*25

INSTALL TWO #10 RING TERMS

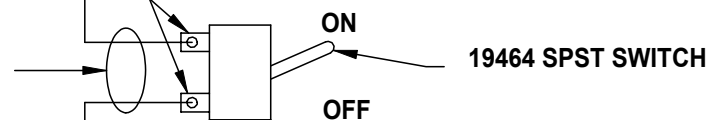

#14 GAGE RED 12V SOURCE/BATTERY 01025-14\*25

TO BATTERY →

NOTE: BLUE/BLK WIRE OF  
20074 HARNESS NOT USED



MANUFACTURING, INC.  
CINCINNATI, OHIO

TITLE

NON-PROP W/ IN-COMPARTMENT CTRLS

DATE

9-26-03D

SECTION

-

HT18/25/40/50 CRANES▲

SUPERSEDES

3-8-02C

20350

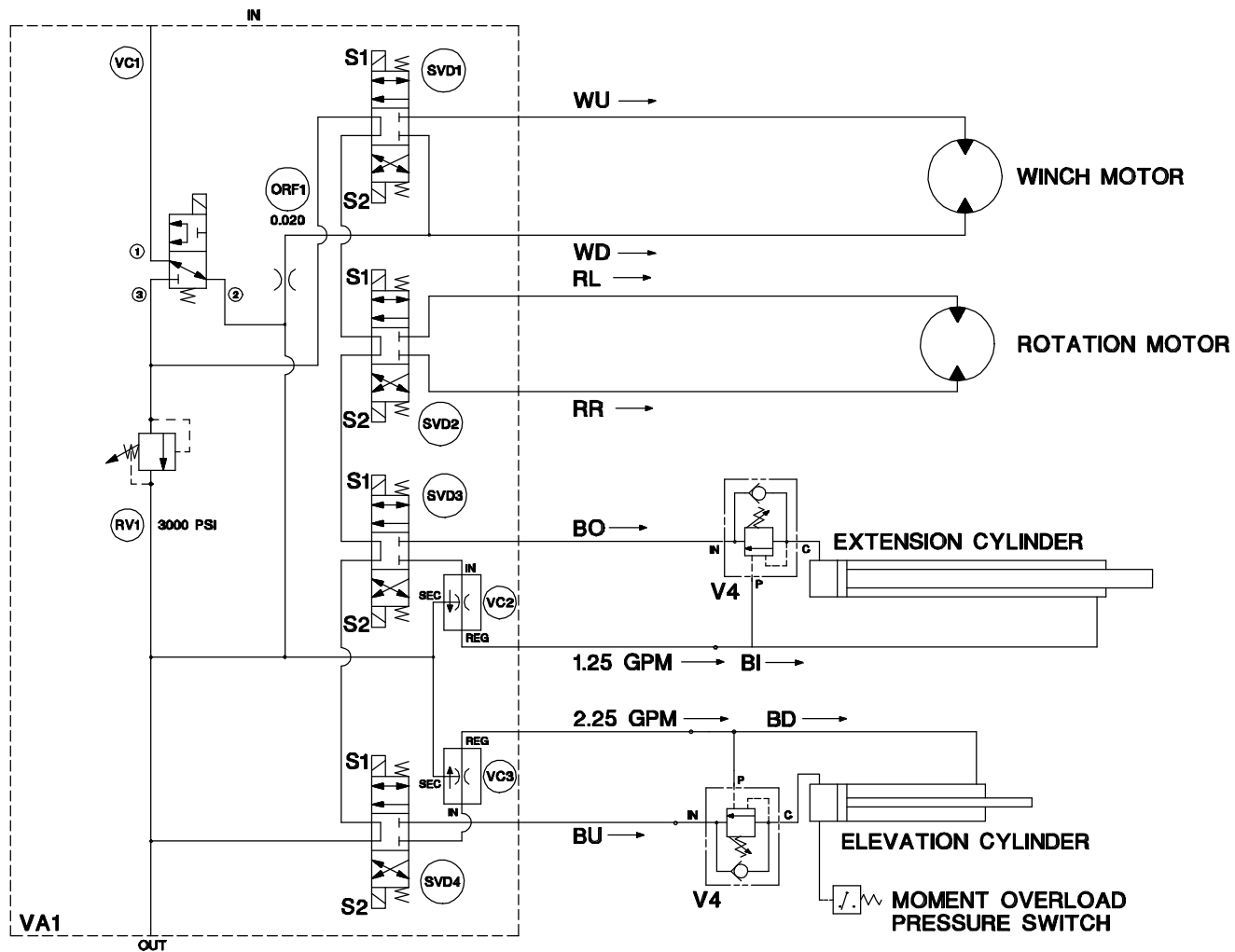

- |      |  |
|------|--|
| VA1  | CONTROL VALVE ASSY                             |
| RV1  | INLET RELIEF VALVE (3000 PSI)                  |
| SVD1 | 3 POSITION-4 WAY VALVE                         |
| SVD2 | 3 POSITION-4 WAY VALVE                         |
| SVD3 | 3 POSITION-4 WAY VALVE                         |
| SVD4 | 3 POSITION-4 WAY VALVE                         |
| V4   | COUNTERBALANCE CARTRIDGE VALVE                 |
| VC1  | PRIORITY FLOW REGULATOR VALVE (SIMPLIFIED REP) |
| VC2  | PRIORITY FLOW REGULATOR VALVE                  |
| VC3  | PRIORITY FLOW REGULATOR VALVE                  |

SERIAL NO. 84030 & UP  
 SERIAL NO. 85030 & UP



TITLE  
 HYDRAULIC SYSTEM DIAGRAM

DATE  
 2-27-98

SECTION  
 C400

HT50KX WITH MANUAL SHUTOFF

SUPERSEDES  
 -

22487

# 20172 PENDANT

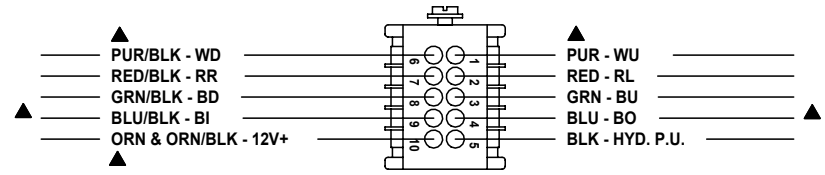
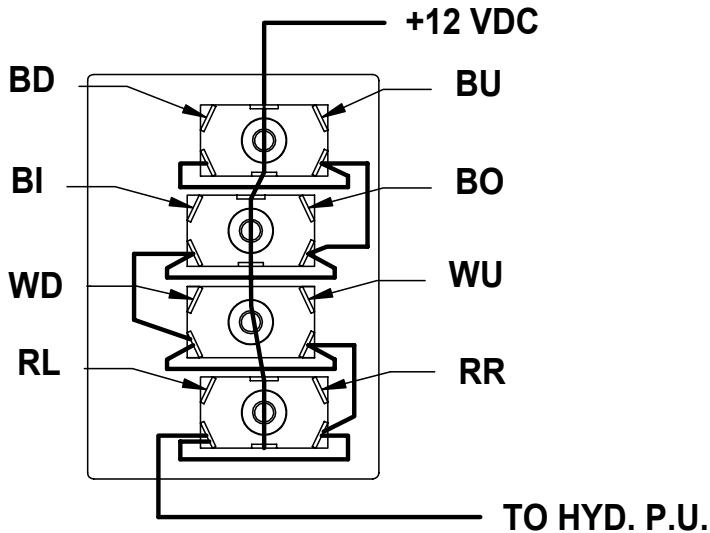
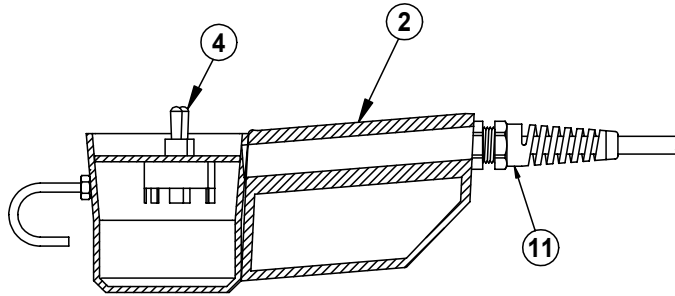
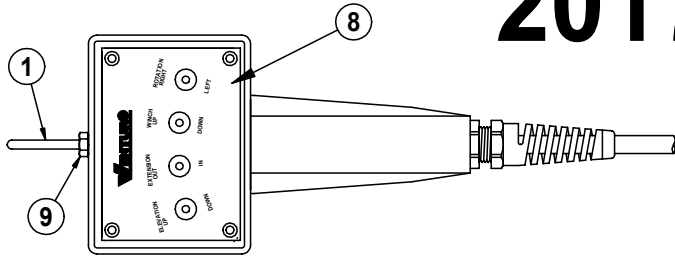

PLUG - BACKSIDE VIEW

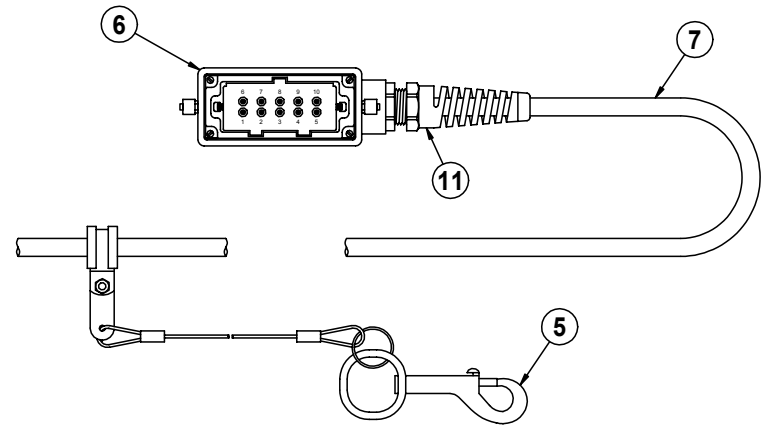

ITEM	QTY	PART NO.	DESCRIPTION
12	-	-	-
11	1	20975	STRAIN RELIEF - M20
10	4	IFHPS#10150A	FLAT HEAD PHILLIPS SCREW - #10 x 1 1/2" LG
9	1	IHNUT-02520	HEX NUT - 1/4-20
8	1	20475	LOGO PLATE, PENDANT CONTROL
7	1	19505-xx	CORD ASSEMBLY (xx = LENGTH IN FT.)
6	1	19482	PLUG ASSEMBLY - 10 + 1 POLE
5	1	15913-2	PHAN., CLAMP AND TETHER ASSEMBLY
4	4	20137	TOGGLE SWITCH
3	1	20199	JUMPER - 3-1/2" LONG - 7 JUMPS
2	1	20154	PENDANT HOUSING
1	1	11557	PENDANT HOOK

**VENTURO** MANUFACTURING, INC.  
CINCINNATI, OHIO

TITLE  
**REPLACEMENT PARTS DRAWING**

HT25KX, HT40KX, HT50KX NON-PROP

DATE  
**1-12-04C**

SUPERSEDES  
**10-1-03B**

SECTION  
-  
**20278**

# 20410 RADIO REMOTE FOR NON-PROPORTIONAL HYDRAULIC CRANES

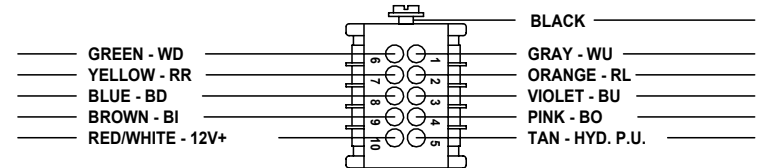
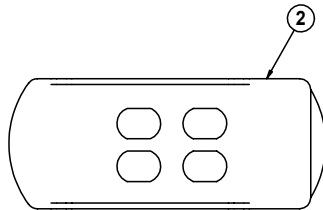

PLUG - BACKSIDE VIEW

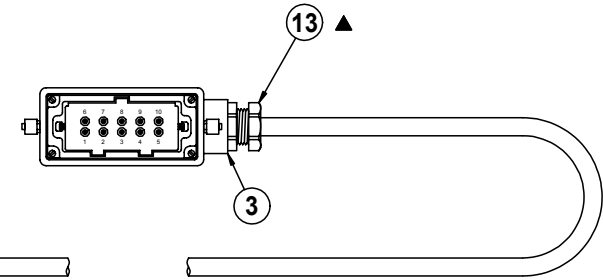
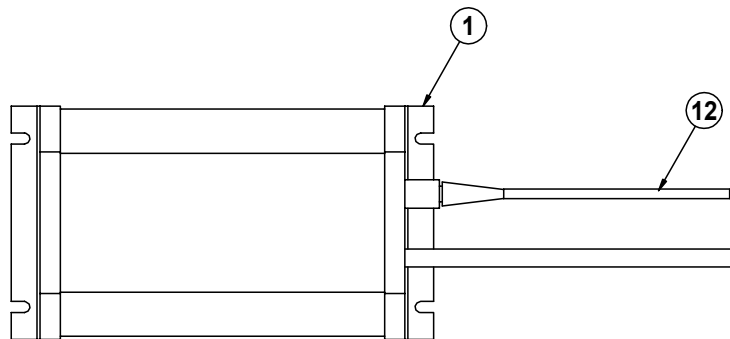

LENGTH = 48" (IN-COMPARTMENT CONTROL)  
LENGTH = 20" (CRANE MOUNTED RECEIVER)

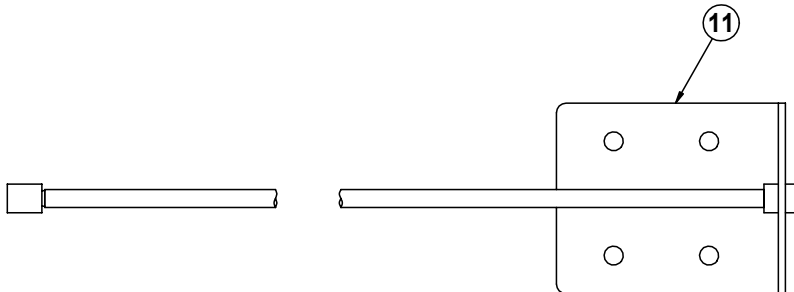

NOTE: ANTENNA IS SUPPLIED WITH RADIO, ALSO AVAILABLE AS A REPLACEMENT PART

ITEM	QTY	PART NO.	DESCRIPTION
13	1	20405	CABLE GLAND - M20
12	1	20966	ANTENNA (SEE NOTE)
11	1	20965	REMOTE ANTENNA ASSEMBLY (OPTIONAL)
10	1	ITERM16G#10RG	16GA #10 RING TERMINAL (NOT SHOWN)
9	10	ITERM16G-PIN	16 GA PIN TERMINAL (NOT SHOWN)
8	4	IHNUT-#1024	HEX NUT - #10-24 (NOT SHOWN)
7	2	ILWSH-#10-STAR	LOCK WASHERS - STAR (NOT SHOWN)
6	3	ILWSH-#10	#10 LOCK WASHERS (NOT SHOWN)
5	8	IFWSH-#10	#10 FLAT WASHERS (NOT SHOWN)
4	4	IPHCS-#10075	PAN HEAD CAP SCREWS - #10-24 - (NOT SHOWN)
3	1	19482	10 PIN CONNECTOR
2	1	20411-TX	REMTRON RADIO TRANSMITTER
1	1	20411-RX	REMTRON RADIO RECEIVER



MANUFACTURING, INC.  
CINCINNATI, OHIO

TITLE

REPLACEMENT PARTS DRAWING

DATE

10-8-03C

SECTION

C400

HT25KX, HT40KX, HT50KX - NON-PROP.

SUPERSEDES

7-2-03B

20417



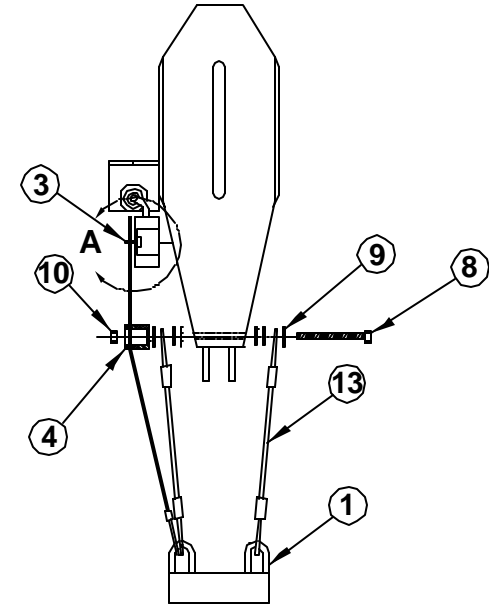
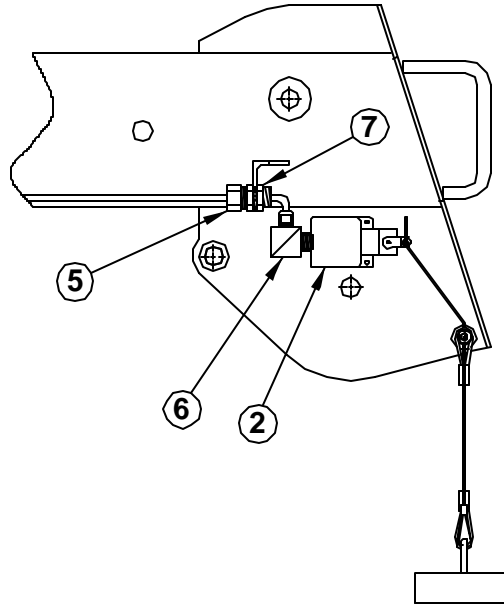
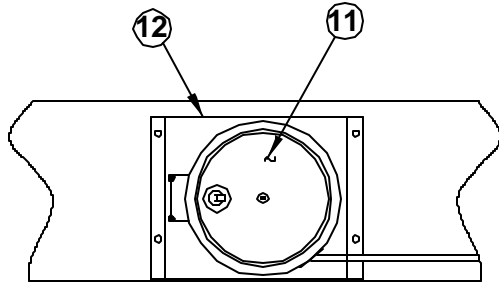

NOTE: FOR OPTIONAL RIGHT HAND CORD REEL.

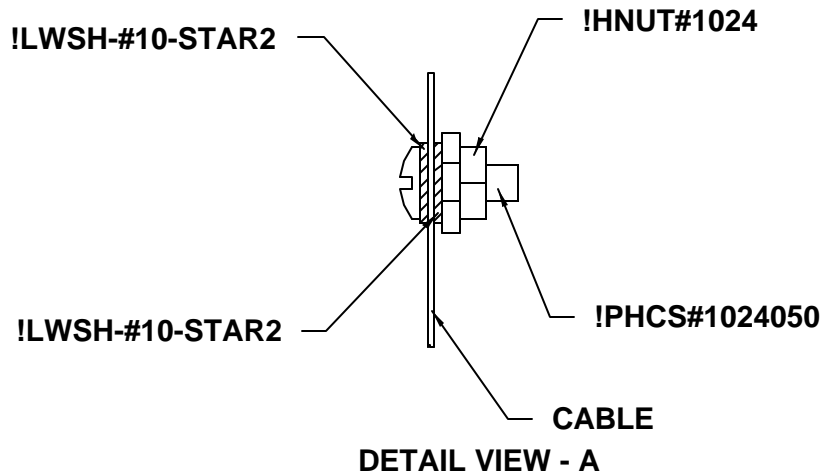

13	2	20951-3	HANGER CABLE
12	1	19058	COVER - CORD REEL
11	1	22388	CORD REEL ASSEMBLY - RH
10	1	!LNUT-02520	LOCK NUT, NYLON 1/4-20
9	6	!FWSH-025	FLAT WASHER 1/4
8	1	!HHCS02520275-5	HHCS 1/4-20 x 2-3/4" GR. 5
7	1	PL-20-469	LOCKNUT (1/2" PIPE)
6	1	19060	STRAIN RELIEF - 90DEG
5	1	22455	STRAIN RELIEF - STRAIGHT (1/2" PIPE)
4	1	22454	CABLE GUIDE - BLACK DELRIN
3	1	22456	CONNECTOR / SET-COLLAR ASSEMBLY
2	1	22453	MICROSWITCH
1	1	19377-3	WEIGHT ASSY.
ITEM	QTY	PART NO.	DESCRIPTION



MANUFACTURING, INC.  
CINCINNATI, OHIO

TITLE  
**REPLACEMENT PARTS DWG - RH CORD REEL**

HT40KX, HT50KX

DATE  
5-21-04D

SUPERSEDES  
7-3-03C

SECTION  
C400

**22449**

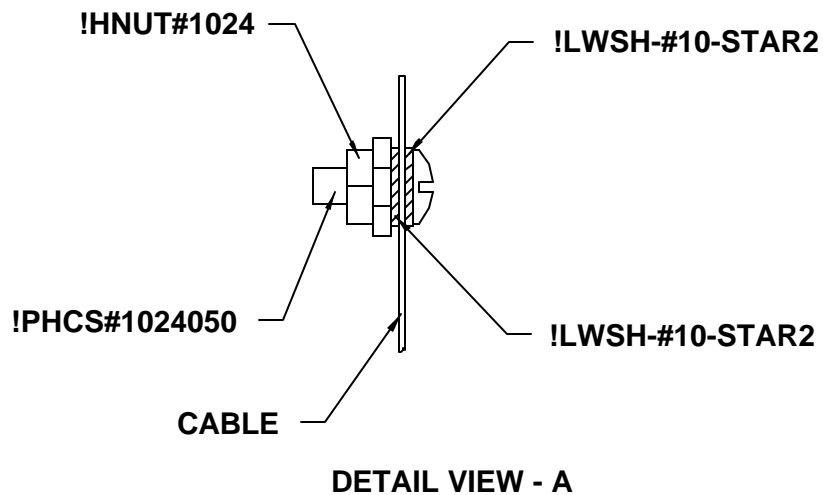
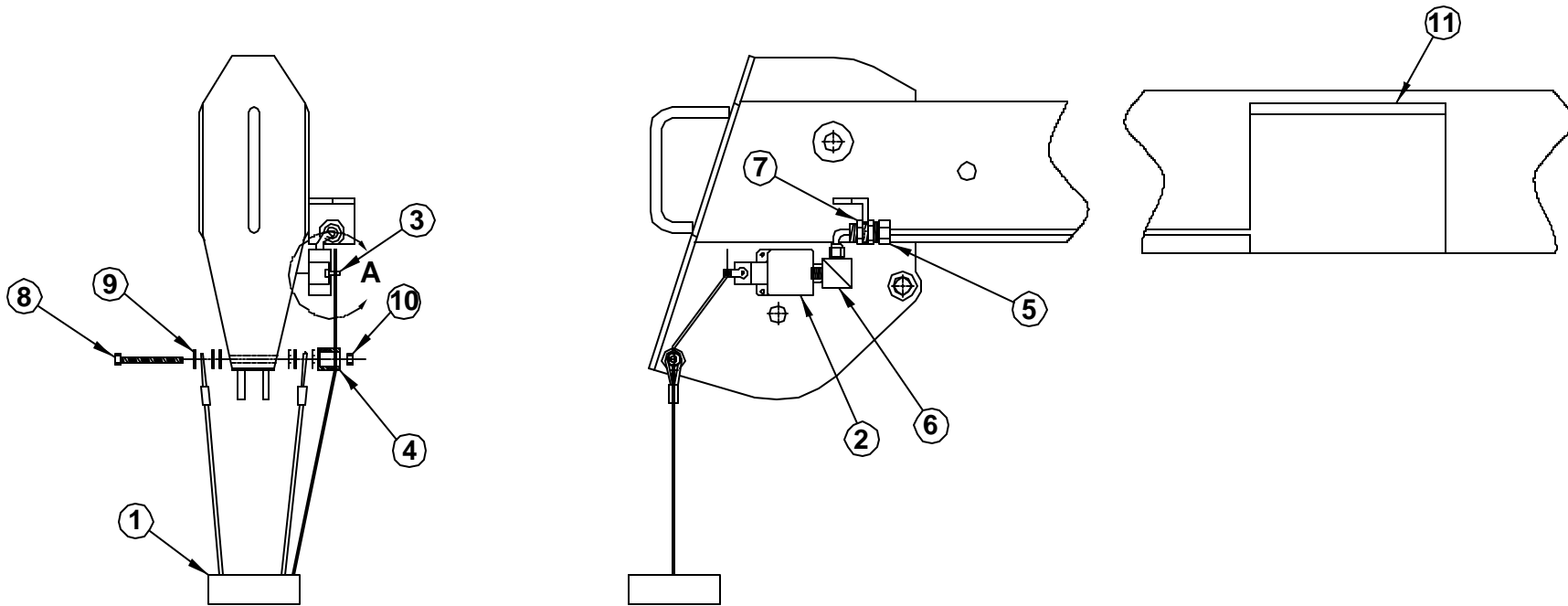

▲  
NOTE: FOR STANDARD LEFT HAND CORD REEL

12	1	20951-3	HANGER CABLE
11	1	22683	CORD REEL ASSEMBLY - LEFT HAND
10	1	!LNUT-02520	LOCK NUT, NYLON 1/4-20
9	6	!FWSH-025	FLAT WASHER 1/4
8	1	!HHCS02520275	HHCS 1/4-20 x 2-3/4" GR. 5
7	1	PL-20-469	LOCKNUT (1/2" PIPE)
6	1	19060	STRAIN RELIEF - 90DEG
5	1	22455	STRAIN RELIEF - STRAIGHT (1/2" PIPE)
4	1	22454	CABLE GUIDE - BLACK DELRIN
3	1	22456	CONNECTOR / SET-COLLAR ASSEMBLY
2	1	22453	MICROSWITCH
1	1	19377-3	WEIGHT ASSY.
ITEM	QTY	PART NO.	DESCRIPTION



MANUFACTURING, INC.  
CINCINNATI, OHIO

TITLE  
REPLACEMENT PARTS DWG - LH CORD REEL

DATE  
5-21-04C

SECTION  
C400

22685 ANTI-TWO BLOCK SYSTEM

SUPERSEDES  
9-23-03B

**22684**

# 19294 PTO PACKAGES

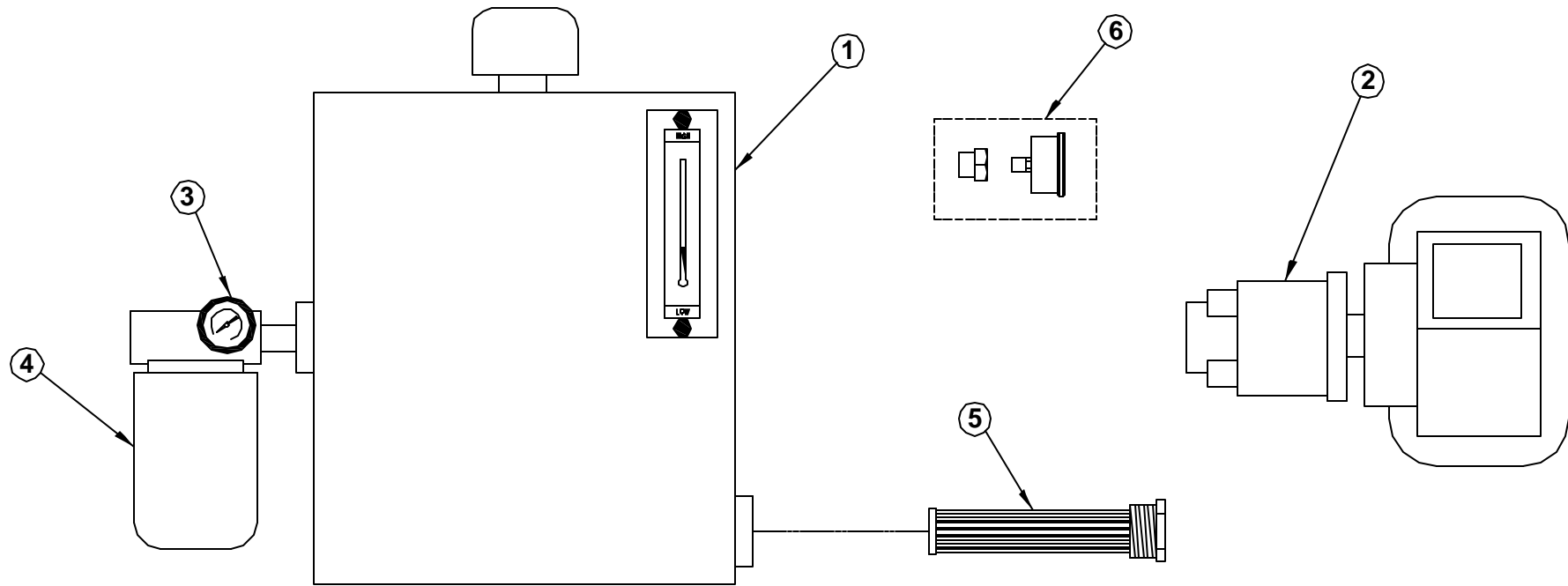

PUMP	MOUNTING	RECOMMENDED GPM (RPM)
19296-1.60	SAE "A" 9 TOOTH	HT18 - STD. - 1.75 GPM (1110 RPM)
		HT25 - STD. - 2.00 GPM (1250 RPM)
19296-2.64	SPLINED SHAFT	HT40 - STD. - 2.6 GPM (1000 RPM)
		HT50 - STD. - 3.0 GPM (1150 RPM)
19296-4.00 ▲		HT18 - PROP. - 3.5 GPM (875 RPM)
		HT25 - PROP. - 4.0 GPM (1000 RPM)
19296-5.00		HT40 - PROP. - 5.0 GPM (1000 RPM)
		HT50 - PROP. - 6.0 GPM (1200 RPM)

6	1	22263	PRESSURE GAUGE ASSEMBLY
5	1	19300	SUCTION SCREEN - 100 MESH
4	1	19298	FILTER ASSY, RETURN - 10 MICRON
3	1	19297	PRESSURE GAUGE - RETURN
2	1	SEE CHART	PTO PUMP - HT18/25/40/50KX
1	1	19295	RESERVOIR TANK - 10 GALLON
ITEM	QTY	PART NO.	DESCRIPTION



MANUFACTURING, INC.  
CINCINNATI, OHIO

TITLE  
**REPLACEMENT PARTS DWG**

**PTO KIT - HT18/25/40/50KX**

DATE  
**7-13-04F**

SUPERSEDES  
**3-4-04E**

SECTION  
**C400**

**22448**