

PARTS & INSTALLATION MANUAL

24962-CD/PH(E)(-LC)

Included in this manual:

24962-CD/PH(E)(-LC)

- Stabilizer with Manual Pullout and Crank-Down/Hydraulic Legs
- Available in “Less Crosstube” (-LC) configuration

24962-CD/PH(E)(-LC)

INST-24860 - 3/14/2024 (Rev: A0)

7607200A	SECTION 200: INSTALLATION
25480	INSTALLATION GUIDELINES
24875	ISOMETRIC VIEW
24876	OVERALL DIMENSIONS - 24962-CD
24877	OVERALL DIMENSIONS - 24962-PH
24878	RECOMMENDED MOUNTING TO TRUCK FRAME
24867	SMALL PARTS IMAGE
25447-1	SELECTOR VALVE OVERVIEW
24872	HYDRAULIC MAPPING - 1 OF 3
24873	HYDRAULIC MAPPING - 2 OF 3
24874	HYDRAULIC MAPPING - 3 OF 3
15660-2	BATTERY CABLES & COMPONENTS
25485	RECOMMENDED DEPARTURE ANGLE
24871	MOUNTING OUTRIGGER LEGS
24868	LESS-CROSSTUBE ASSY - 1 OF 3
24869	LESS-CROSSTUBE ASSY - 2 OF 3
24870	LESS-CROSSTUBE ASSY - 3 OF 3
24879	WELD DETAIL, HYDRAULIC BULKHEADS

7607400A	SECTION 400: REPLACEMENT PARTS
24861	24962-CD REPLACEMENT PARTS LIST
24862	24962-CD REPLACEMENT PARTS DRAWING
24863	24962-PH REPLACEMENT PARTS LIST
24864	24962-PH REPLACEMENT PARTS DRAWING
24865	LEG REPLACEMENT PARTS LIST
24866	LEG REPLACEMENT PARTS DRAWING
25465-1	19401 H.P.U. REPLACEMENT PARTS LIST
25466-1	19401 H.P.U. REPLACEMENT PARTS DWG
25476-1	25477 H.P.U. REPLACEMENT PARTS LIST
25475-1	25477 H.P.U. REPLACEMENT PARTS DWG
12-00073_VNT1	WARRANTY PAGE

SECTION 200

INSTALLATION



VENCO VENTURO INDUSTRIES LLC
CINCINNATI, OHIO

STABILIZER INSTALLATION GUIDELINES

Read instructions completely prior to starting installation. If this unit is to be installed on a Venturo crane body, continue to the stabilizer assembly section of this manual.

Prior to mounting the stabilizer crosstube, orient the stabilizer so the longer pullout is on the crane side of the truck.

REAR MOUNTED

Crosstube should be centered at the rear of the truck and tied into the truck frame, body longills, and crane support. Installer is responsible for proper mounting brackets and hardware that will be needed during this process. If unit is to be mounted on a service body, do not attach crosstube to body sheet metal unless otherwise specified. Allow clearance between crosstube and body for the stabilizer legs to be fully retracted. Consult chassis up-fitter guide prior to installation for proper welding and bolting procedures to chassis.

See the 'RECOMMENDED MOUNTING TO TRUCK FRAME' page

Leg installation (refer to assembly section of manual) legs are adjustable to maintain proper ground penetration of 4" to 6". The stabilizer is designed to level the truck and not lift the chassis off of the ground. They are designed to work in conjunction with the chassis suspension to stabilize the unit with the bulk of the load being supported by the chassis suspension and tires. Tires must be set at the proper pressure according to the chassis manufacture, stabilizers fully extended, and legs deployed on firm, level ground prior to crane use.

IMPORTANT - When legs are fully retracted in the stowed position, a 15° degree departure angle between the bottom of the rear tire and the lowest point of the stabilizer is recommended.

See the 'DEPARTURE ANGLE' page

For hydraulic stabilizers, the control valve and selector valve are supplied in kit. It is the installer's responsibility to supply necessary hoses and fittings between these valves and stabilizer. Refer to proper hydraulic schematic for your particular stabilizer model.

IMPORTANT - The selector valve is designed to separate the crane and stabilizer hydraulic circuits. This will not allow stabilizer use while in crane mode.

FRONT MOUNTED

Front mounted crosstube will be located on top of the chassis frame and welded to body longills. Additional shear plates (installer supplied) to be welded to crosstube and bolted to chassis frame. Crosstube to be spaced away from body for leg clearance when fully retracted. See assembly section of manual for pullout and leg installation detail.



VENCO VENTURO INDUSTRIES LLC
CINCINNATI, OHIO

INSTALLATION GUIDELINES

DATE

12-08-23A

SECTION

C200

STABILIZERS

SUPERSEDES

01-17-17

25480

24962-CD

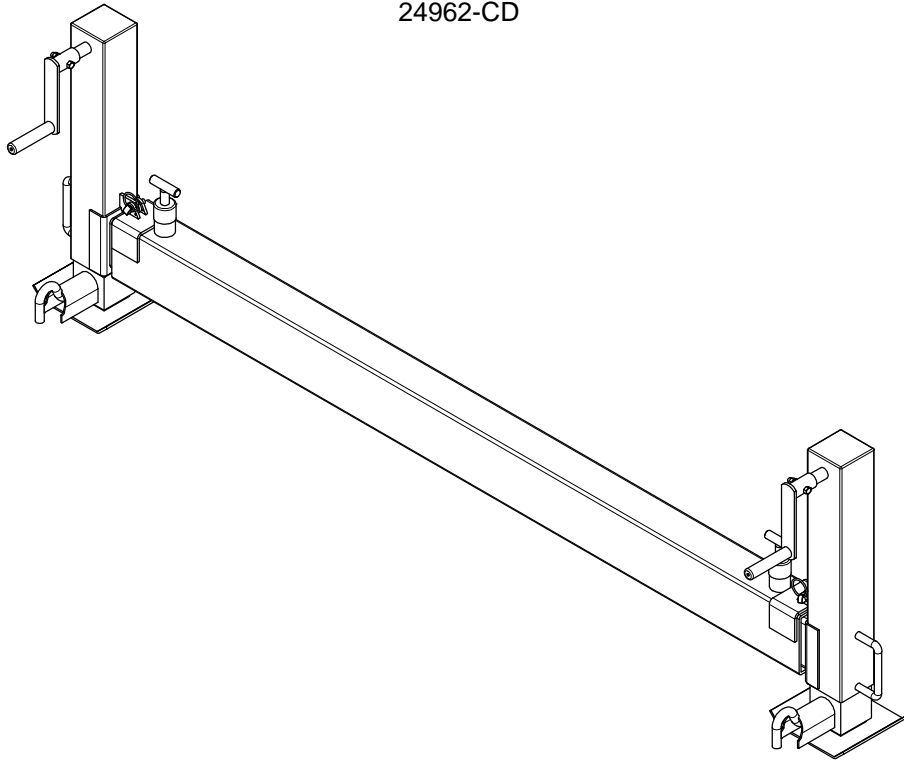

24962-PH

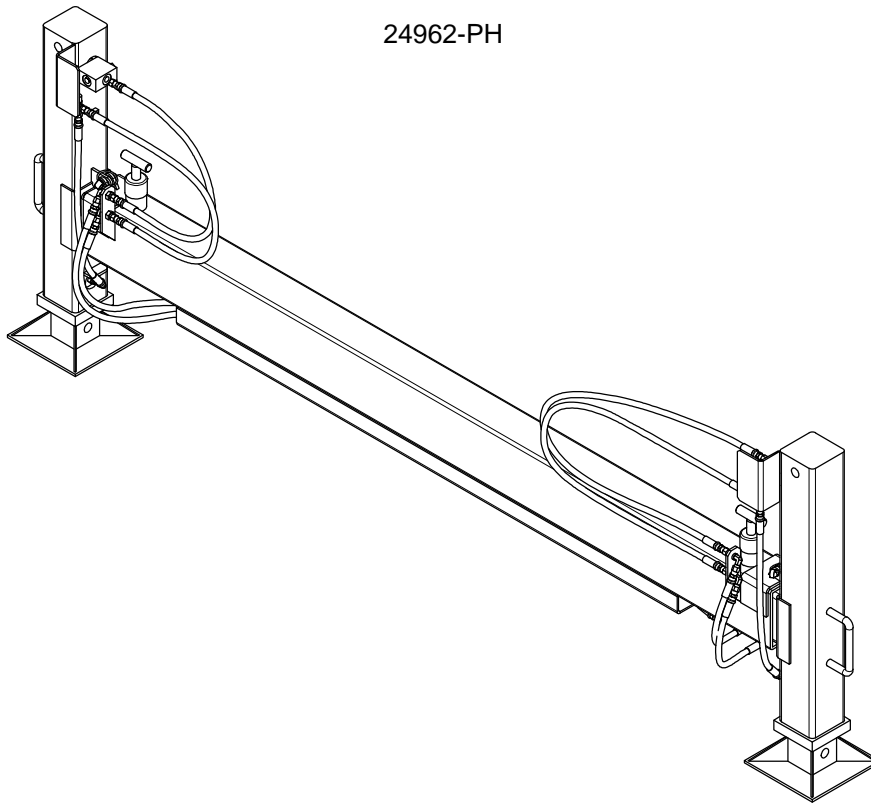

VENCO VENTURO INDUSTRIES LLC
CINCINNATI, OHIO

ISOMETRIC VIEWS

24962 SERIES OUTRIGGERS

DATE
01-31-17

SUPERSEDES
-

PAGE
02

24875

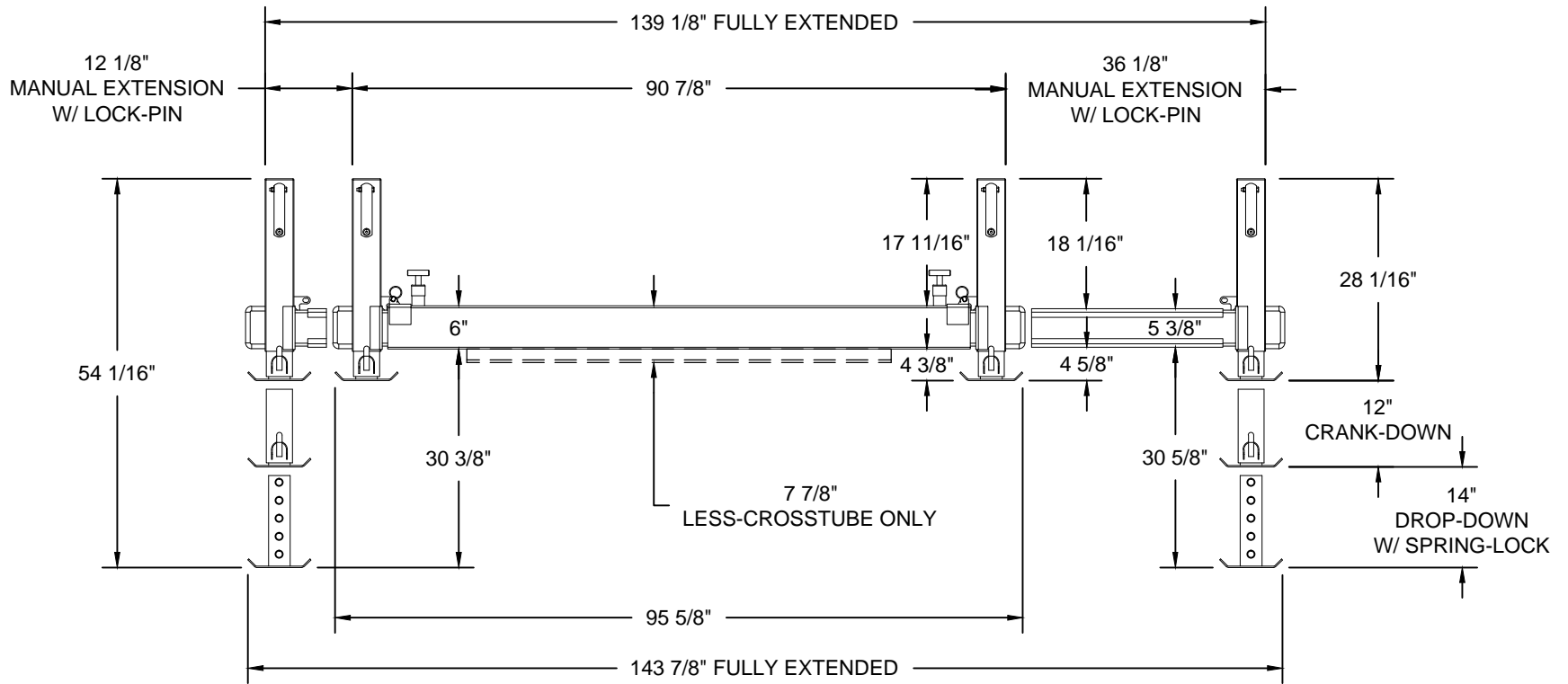
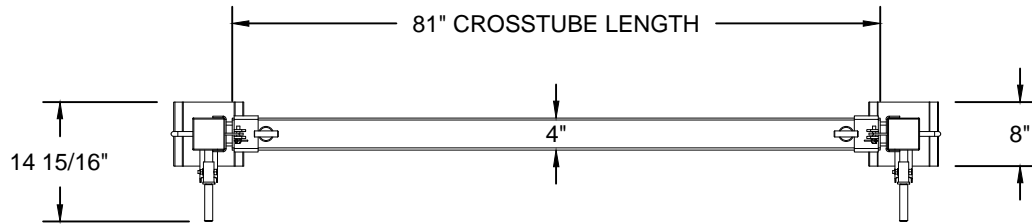

HIGHEST LEG MOUNT SHOWN

12" RANGE ADJUSTABLE
FOR LEG MOUNTING



VENCO VENTURO INDUSTRIES LLC
CINCINNATI, OHIO

OVERALL DIMENSIONS

24962-CD OUTRIGGER

DATE
01-31-17

SUPERSEDES
-

PAGE

03

24876

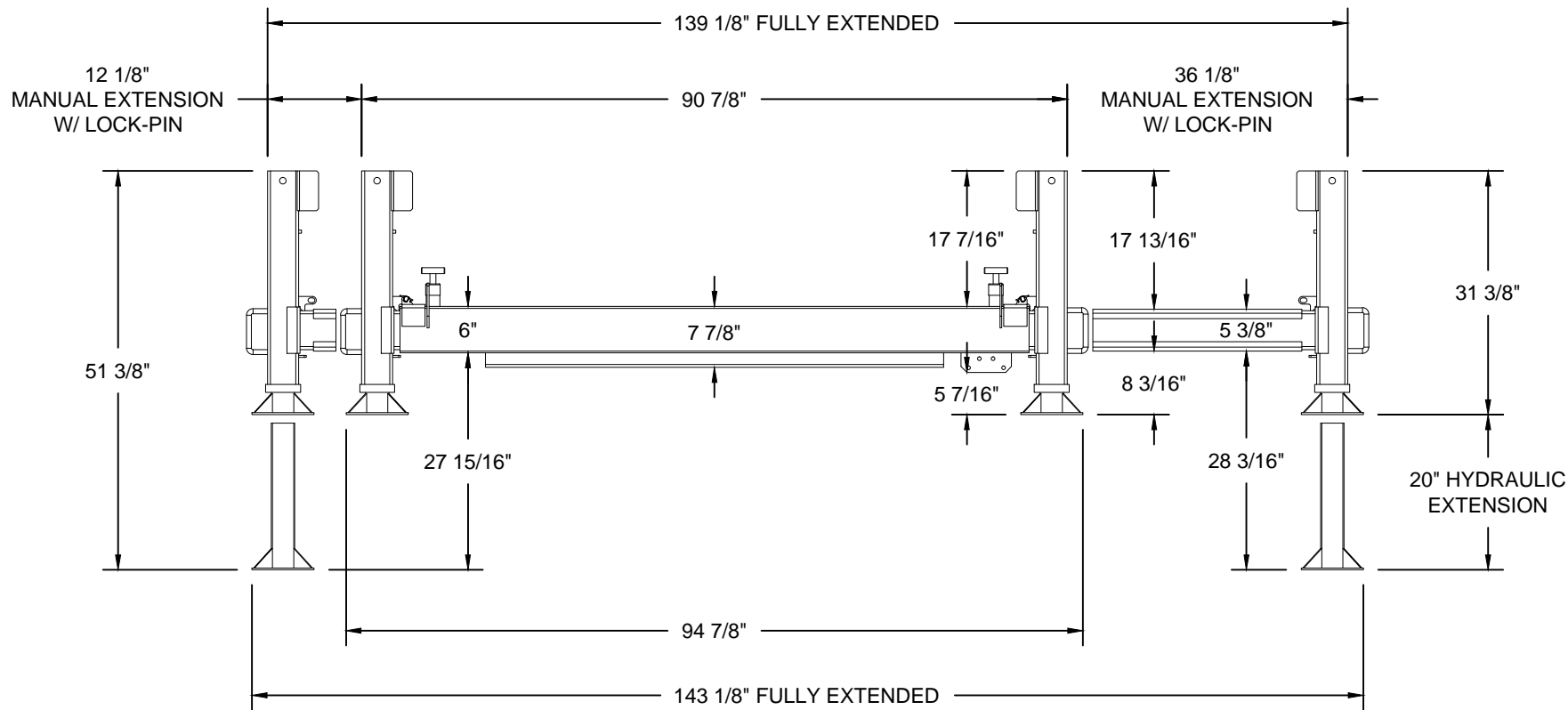
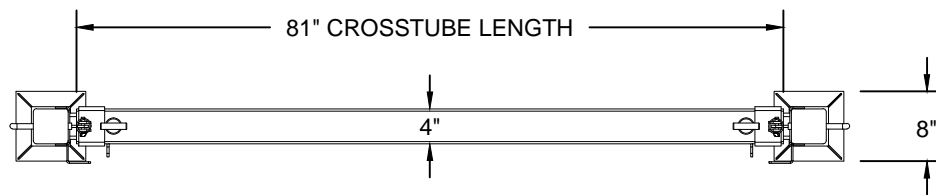

HIGHEST LEG MOUNT SHOWN

10" RANGE ADJUSTABLE FOR LEG MOUNTING



VENCO VENTURO INDUSTRIES LLC
CINCINNATI, OHIO

OVERALL DIMENSIONS

24962-PH OUTRIGGERS

DATE
01-31-17

SUPERSEDES
-

PAGE

04

24877

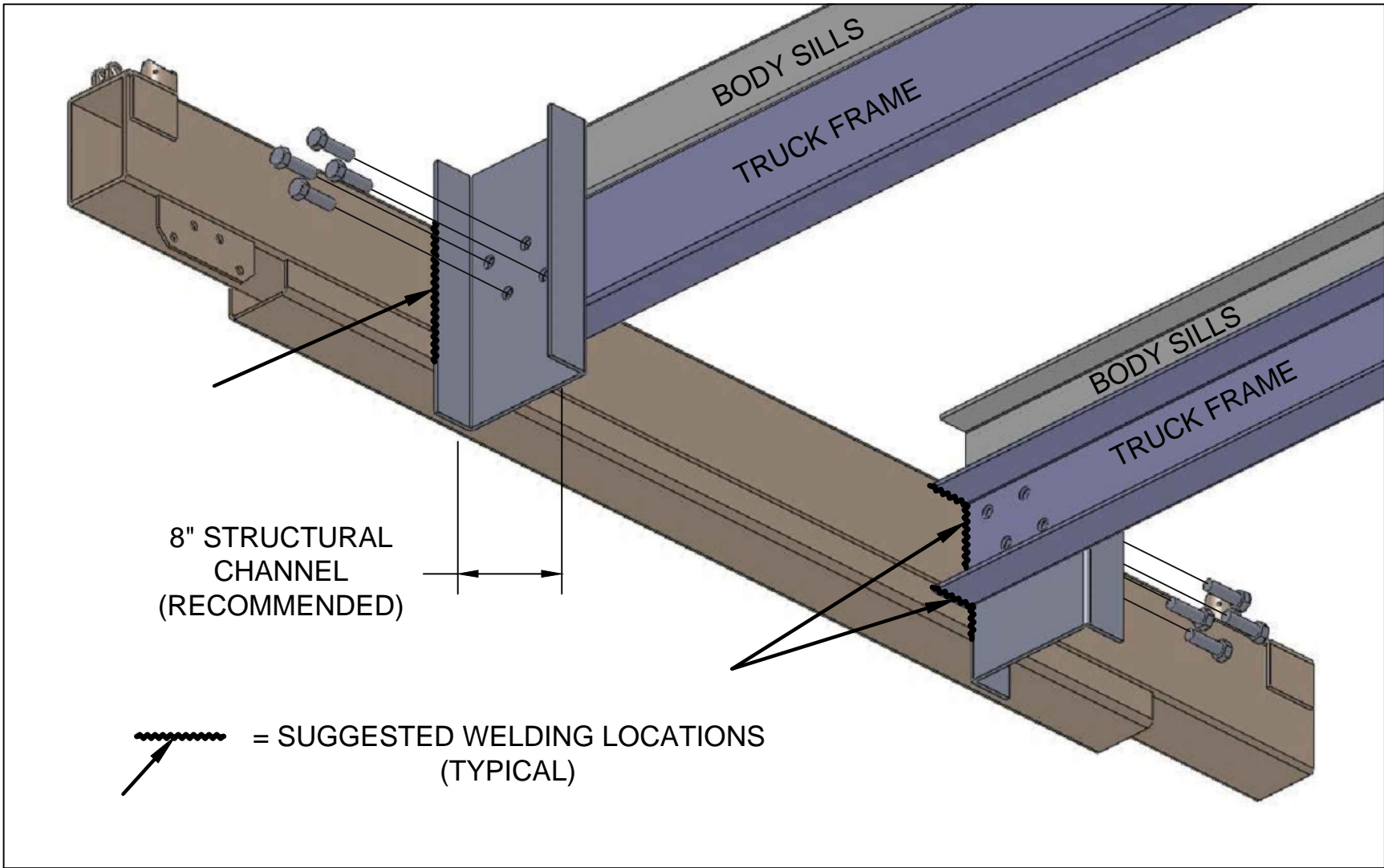

VENCO VENTURO INDUSTRIES LLC
CINCINNATI, OHIO

RECOMMENDED MOUNTING TO TRUCK FRAME

24962 SERIES OUTRIGGERS

DATE
01-31-17

SUPERSEDES
-

PAGE
05

24878

5

6

4

9

19

20

8

12

11

10

9

17

18

16

3

21

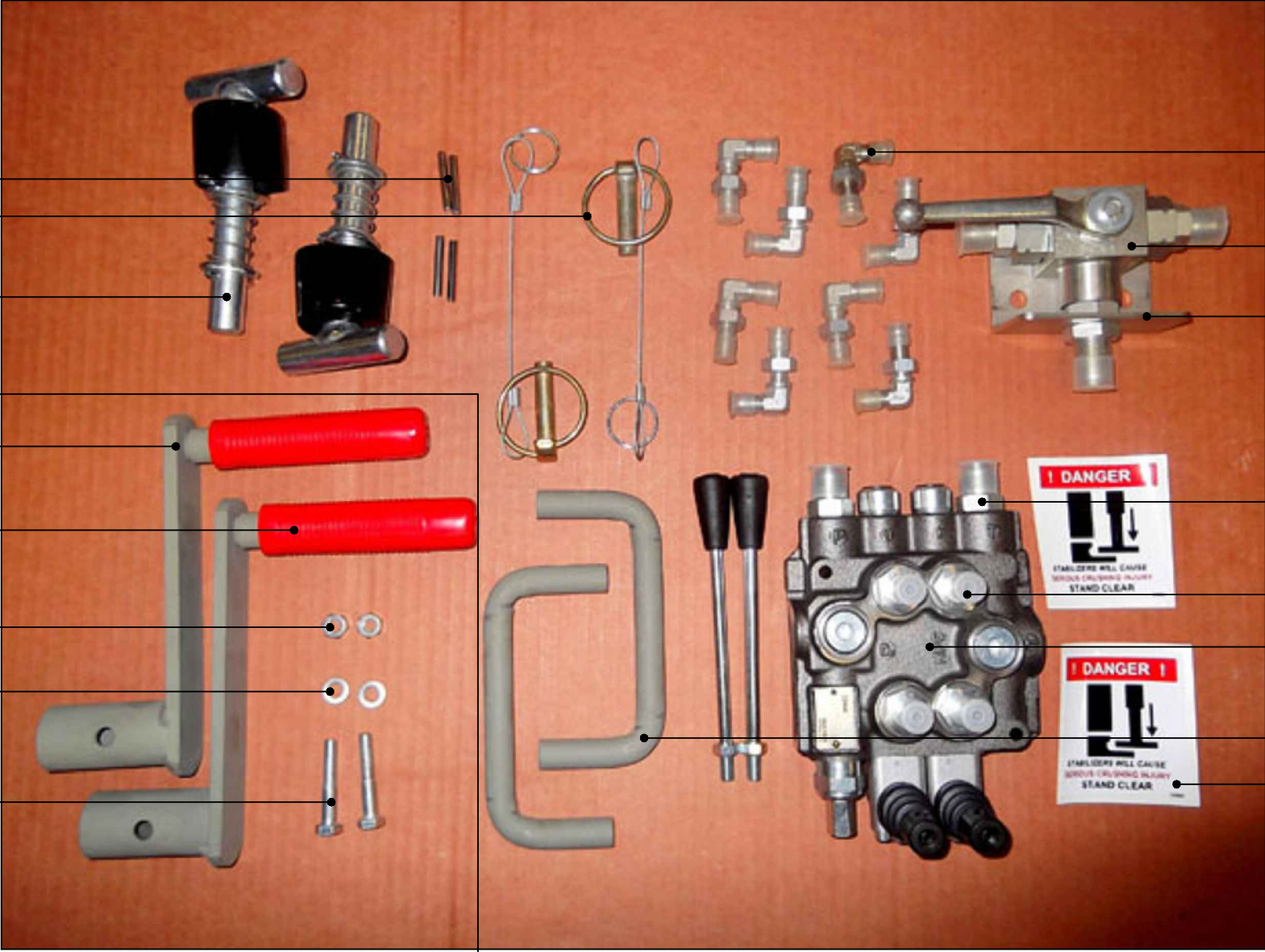

REFERENCE PAGE 17 FOR PART NUMBERS ▲

REFERENCE PAGE 19 FOR PART NUMBERS ▲



VENCO VENTURO INDUSTRIES LLC
CINCINNATI, OHIO

SMALL PARTS IMAGE

24962 SERIES OUTRIGGERS

▲ DATE
01-31-17A

▲ SUPERSEDES
06-06-16

PAGE
06

24867

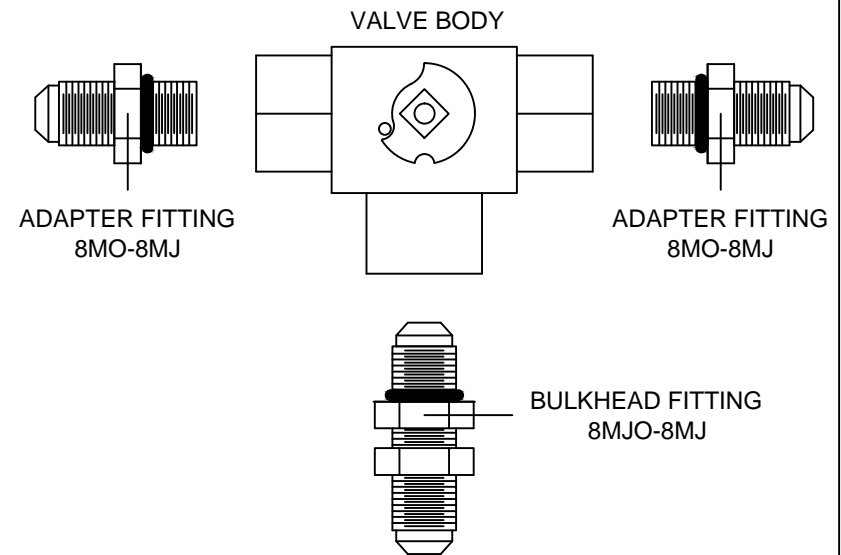
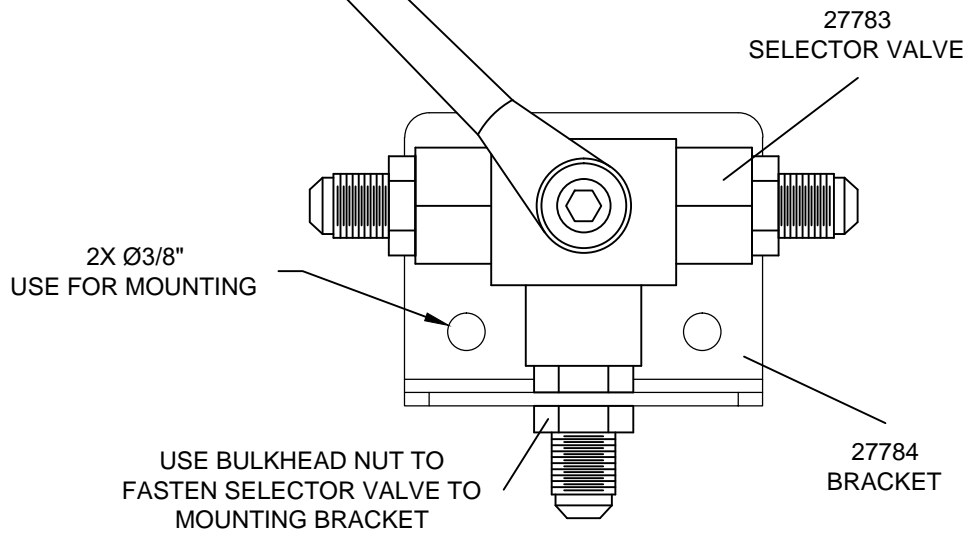
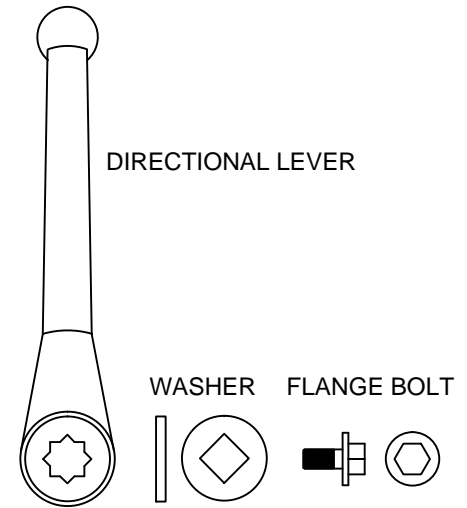
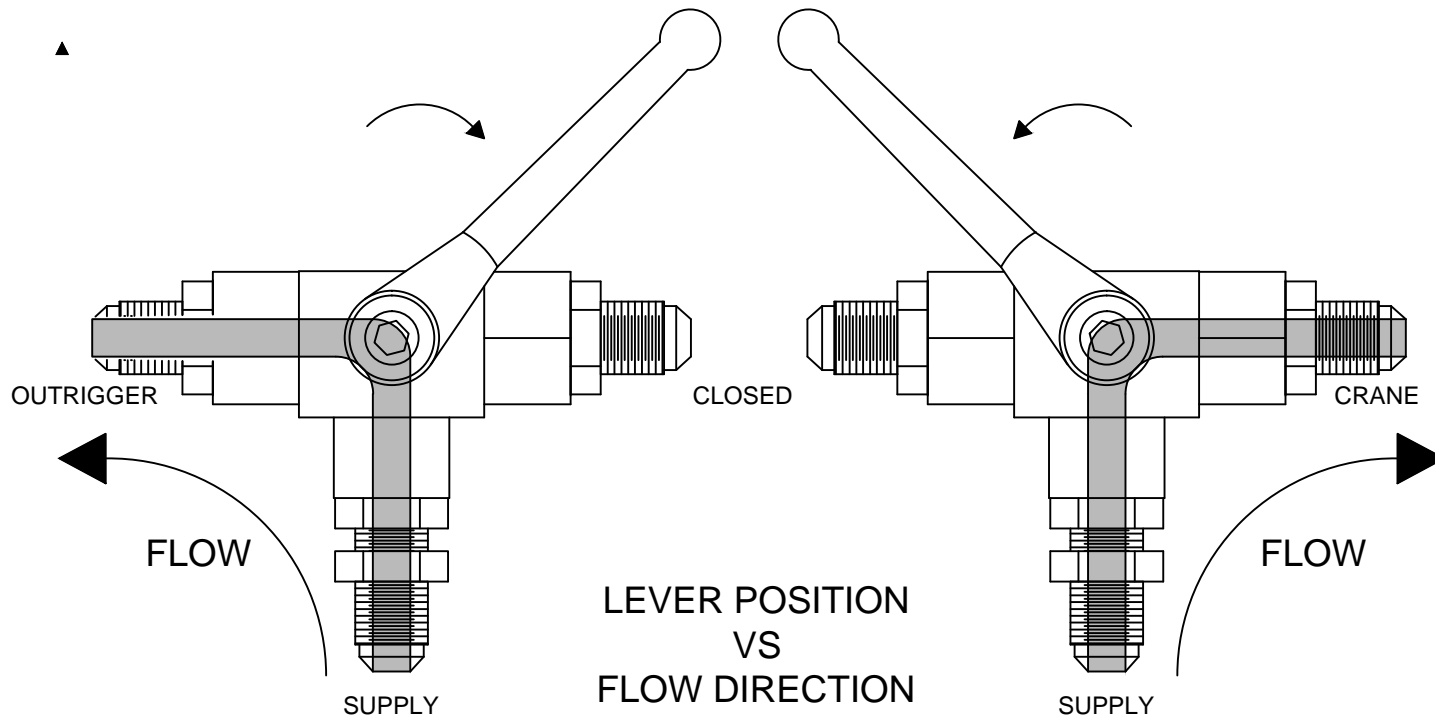

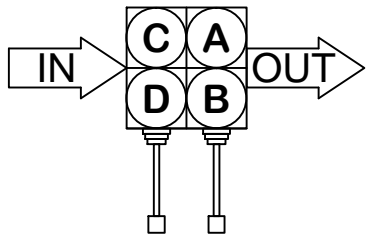
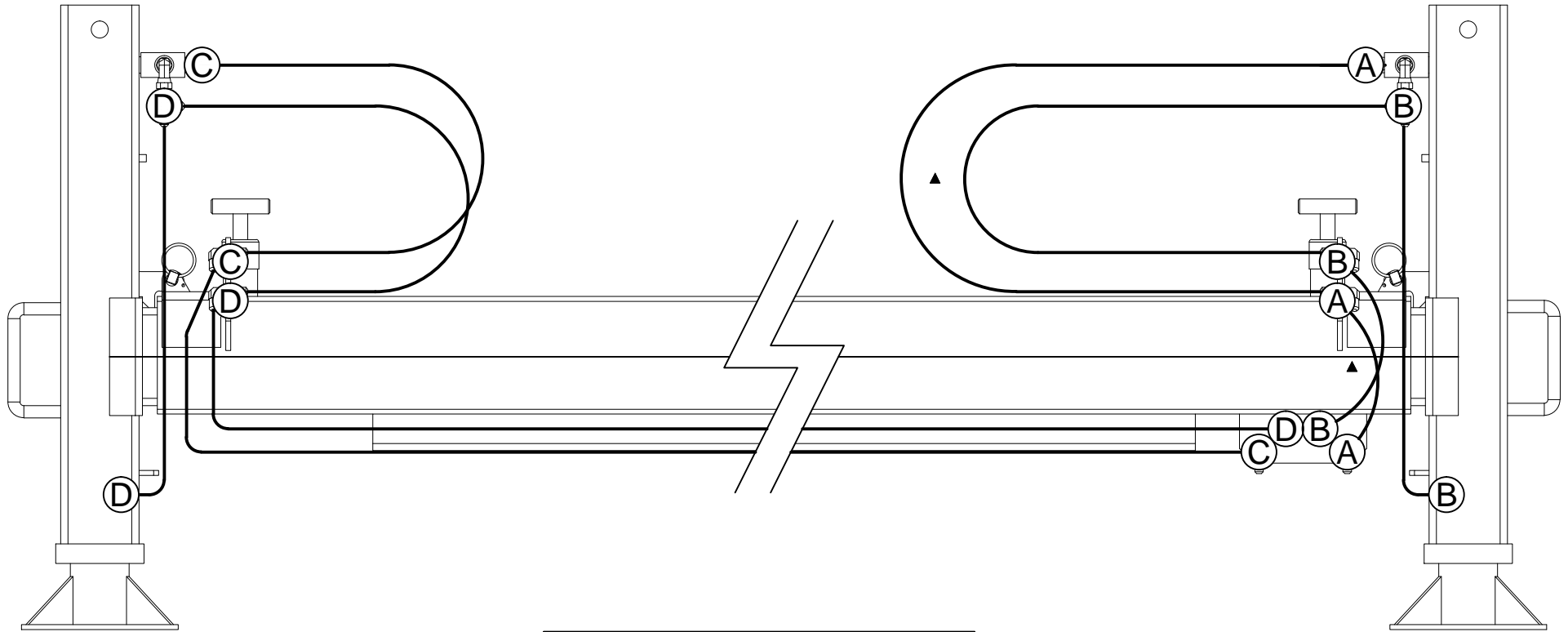

22444
VALVE BANK

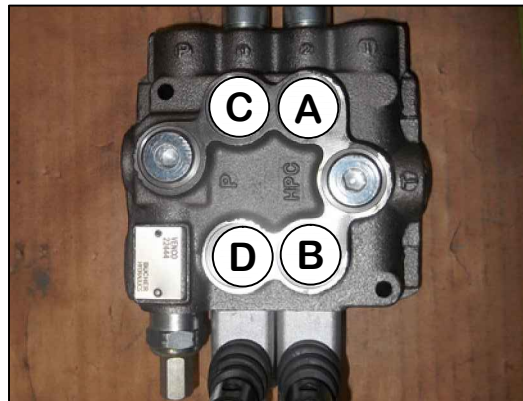

OUTRIGGER FUNCTIONS		
A =	RIGHT LEG	DOWN
B =	RIGHT LEG	UP
C =	LEFT LEG	DOWN
D =	LEFT LEG	UP



VENCO VENTURO INDUSTRIES LLC
CINCINNATI, OHIO

HYDRAULIC MAPPING, 1 OF 3

24962-PH(E) OUTRIGGERS

DATE
09-08-17B

SUPERSEDES
01-31-17A

PAGE
08

24872

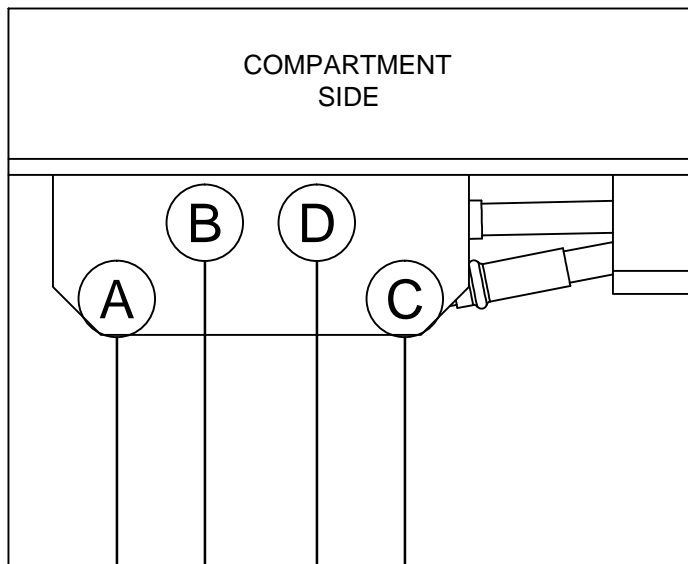

FUNCTIONS		
A =	RIGHT LEG	DOWN
B =	RIGHT LEG	UP
C =	LEFT LEG	DOWN
D =	LEFT LEG	UP
P =	PRESSURE SUPPLY	
T =	TANK RETURN	

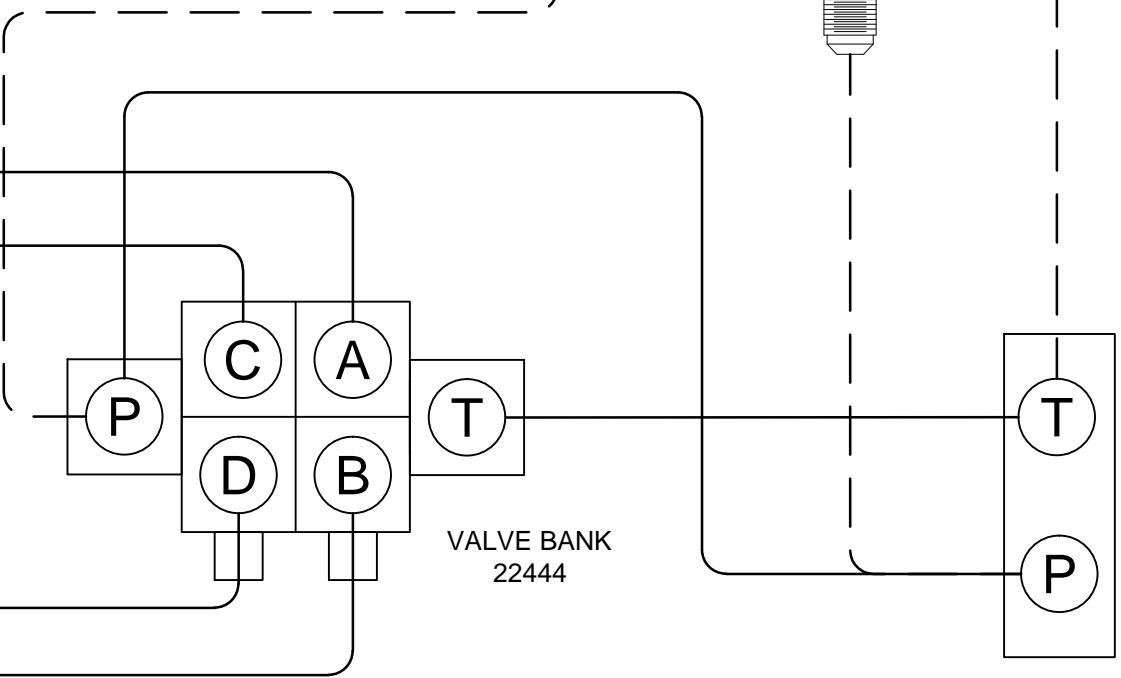
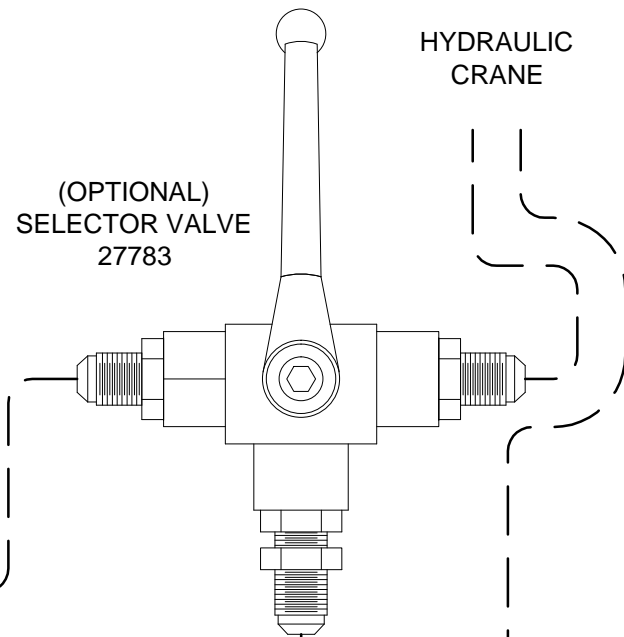

VENCO VENTURO INDUSTRIES LLC
CINCINNATI, OHIO

HYDRAULIC MAPPING, 2 OF 3

24962-PH OUTRIGGER

▲ DATE
01-31-17A

SUPERSEDES
06-06-16

PAGE
09

24873

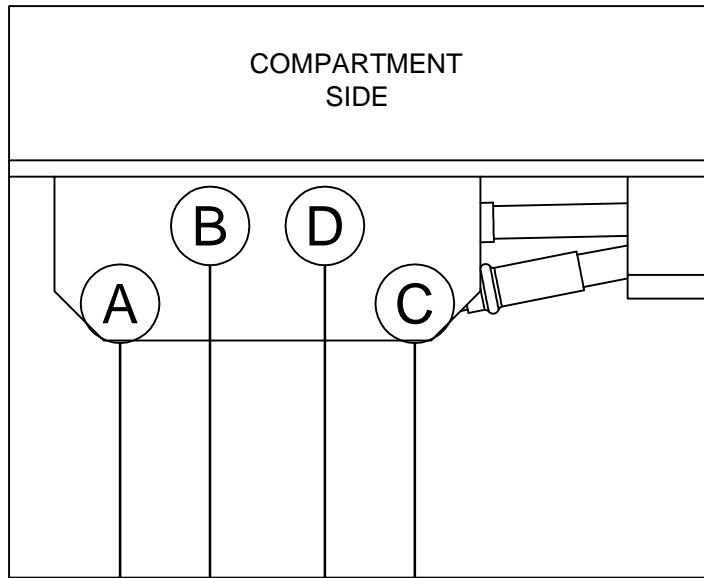

FUNCTIONS		
A =	RIGHT LEG	DOWN
B =	RIGHT LEG	UP
C =	LEFT LEG	DOWN
D =	LEFT LEG	UP
P =	PRESSURE SUPPLY	
T =	TANK RETURN	

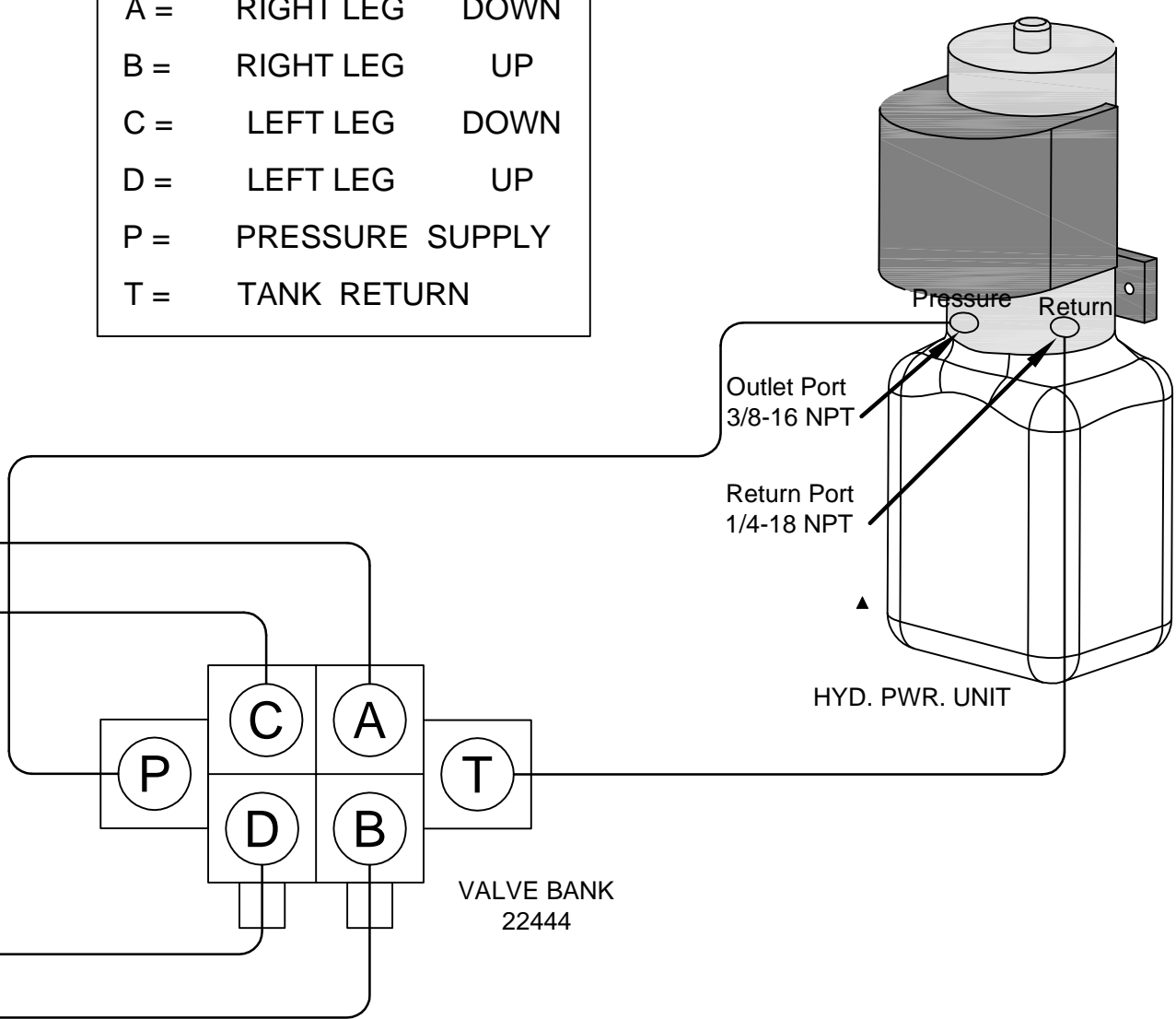

BATTERY REQUIREMENTS

- 12 VOLT *VEHICLE* BATTERY REQUIREMENTS
 - 625 COLD CRANKING AMPS (AT 0° F)
 - 160 MINUTES RESERVE CAPACITY
 - 102 PLATES, 105 AMP-HR
- 12 VOLT *AUXILIARY* BATTERY REQUIREMENTS
 - 450 COLD CRANKING AMPS (AT 0° F)
 - 100 MINUTES RESERVE CAPACITY
 - 78 PLATES, 70 AMP-HR

NOTE: OPERATING WITH THE VEHICLE BATTERY 'ONLY' IS PERMISSIBLE, BUT NOT RECOMMENDED.

RECOMMENDED BATTERY TERMINAL ATTACHMENT

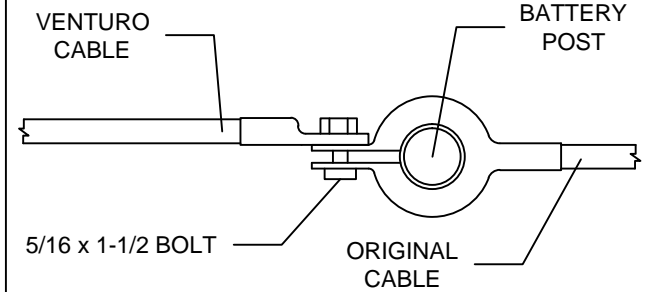

RECOMMENDED CIRCUIT BREAKER

HYDRAULIC POWER UNIT	DESCRIPTION	PART NUMBER
17260-1	250 AMP, MANUAL RESET	22946-250

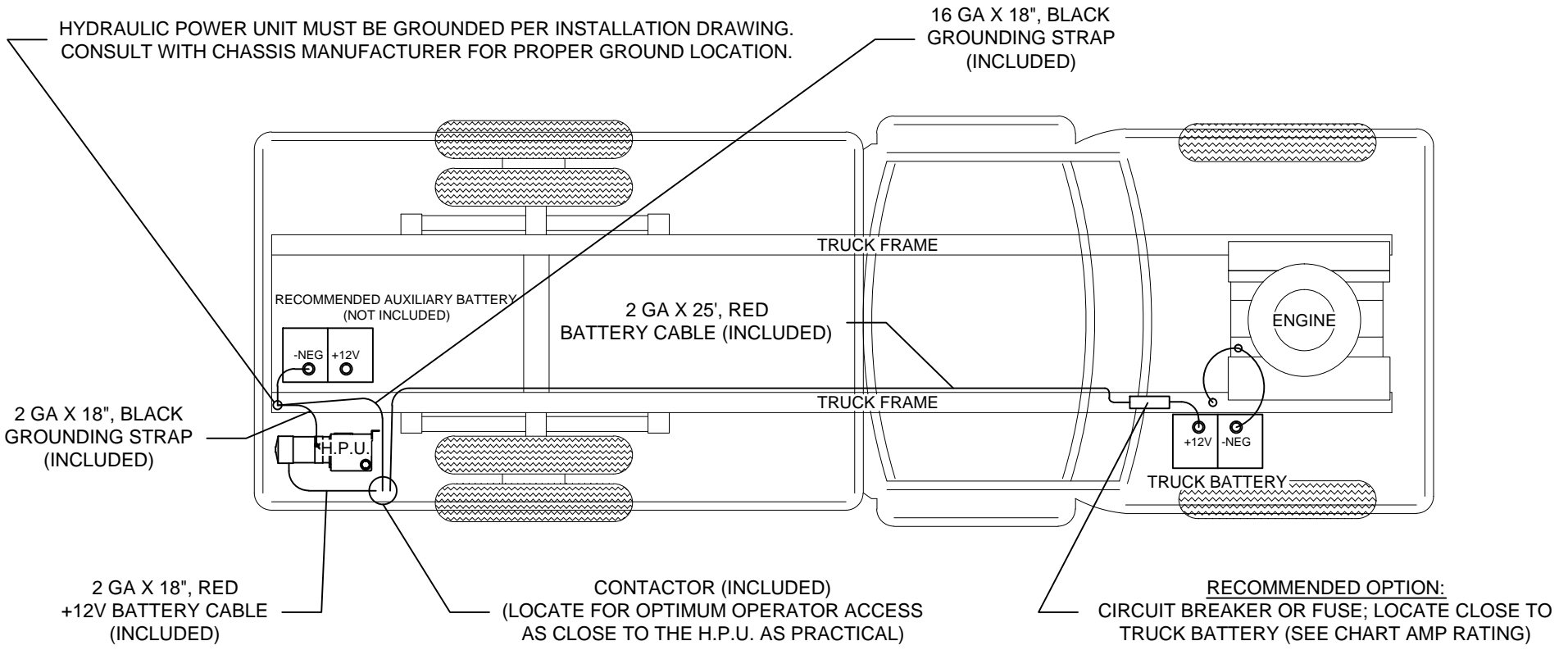

RECOMMENDED DEPARTURE ANGLE



VENCO VENTURO INDUSTRIES LLC
CINCINNATI, OHIO

RECOMMENDED DEPARTURE ANGLE

REAR MOUNTED OUTRIGGERS

DATE

08-25-22A

SUPERSEDES

01-18-17

PAGE

-

25485

FOLLOW INSTRUCTIONS FOR MOUNTING 24962 SERIES OUTRIGGER LEGS.

- ▲ 1. DETERMINE PLACEMENT OF OUTRIGGER LEGS. REFER TO MODEL SPECIFIC 'OVERALL DIMENSIONS' PAGE.
2. WELD A 3/16" BEAD ALL-AROUND EACH PULLOUT CHANNEL.
3. PLACE 24964 DANGER DECAL, [1] ON EACH LEG. SEE RIGHT.

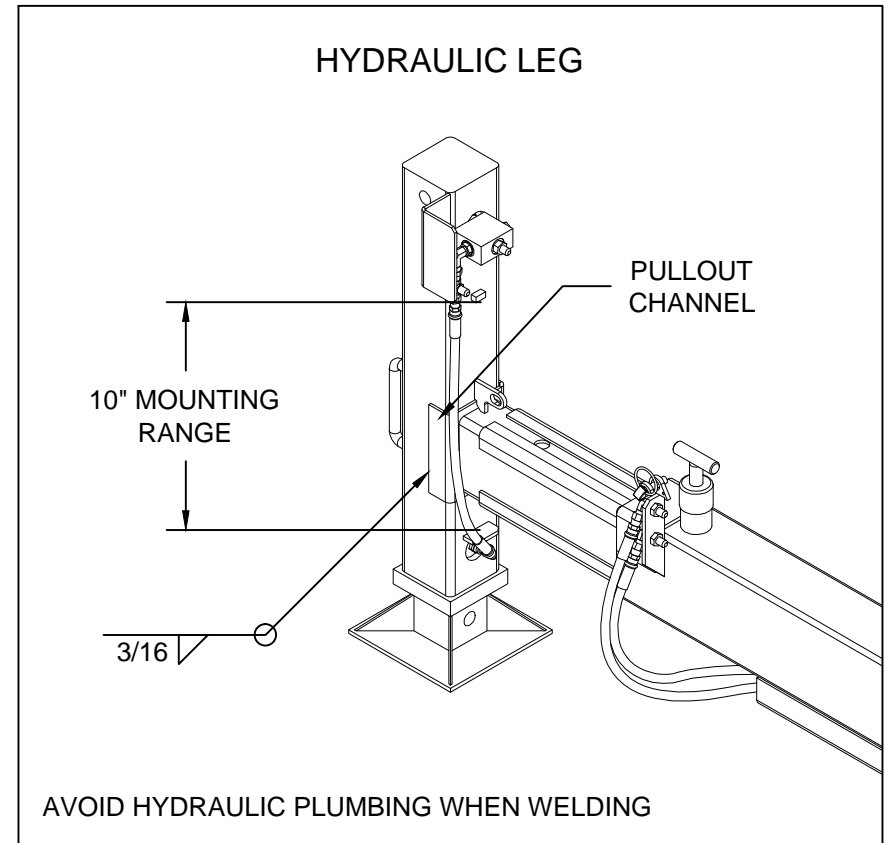
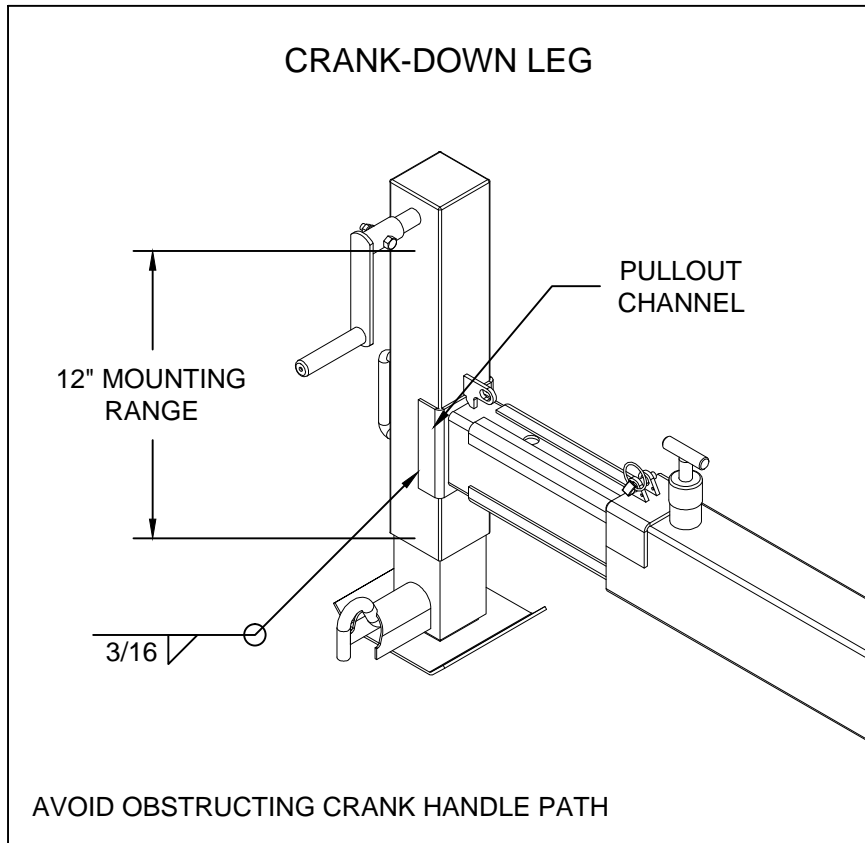
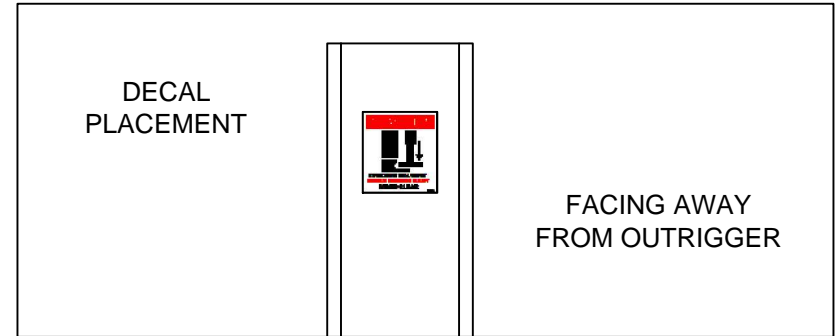

ASSEMBLY OF 24962-CD/PH OUTRIGGER WITH LESS-CROSSTUBE CONFIGURATION



1

SLIDE LONG, RIGHT-SIDE PULLOUT INTO CROSSTUBE
PAGE 17 - ITEM 1

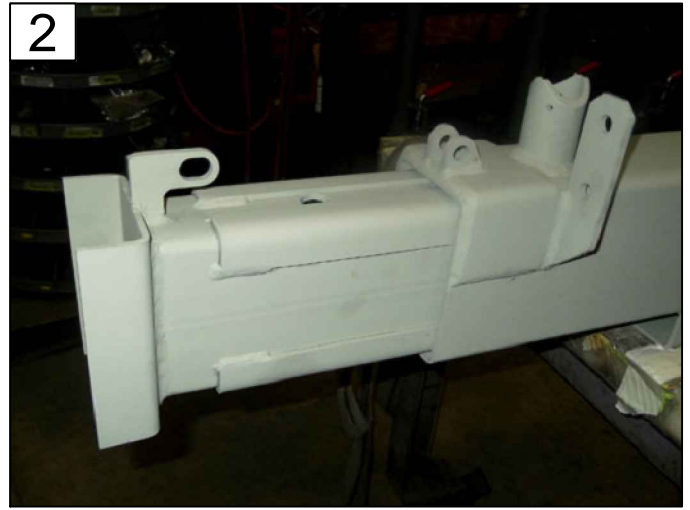

2

SLIDE SHORT, LEFT-SIDE PULLOUT INTO CROSSTUBE
PAGE 17 - ITEM 2



3

ATTACH SECURITY PIN'S KEY-RING ON EITHER TAB
PAGE 17 - ITEM 6



4

ENSURE PIN IS THROUGH ALL TABS & CLAMP MEETS END
REPEAT STEPS 3 & 4 FOR OPPOSITE END



5

GREASE BOTH LOCK PINS' SPRINGS
PAGE 17 - ITEM 4



6

PLACE LOCK PIN AS SHOWN, START ROLL PINS
PAGE 17 - ITEM 5



VENCO VENTURO INDUSTRIES LLC
CINCINNATI, OHIO

LESS-CROSSTUBE ASSY

24962-CD/PH OUTRIGGERS

DATE
01-31-17A

SUPERSEDES
06-06-16

PAGE
14

24868

ASSEMBLY OF 24962-CD/PH OUTRIGGER WITH LESS-CROSSTUBE CONFIGURATION



7

PUSH SPRING-LOADED WASHER DOWN
START DRIVING ROLL PINS THROUGH



8

GUIDE ROLL PINS UNTIL FLUSH ON BOTH ENDS



9

COVER WITH RUBBER BOOT
REPEAT STEPS 5 TO 9 FOR OPPOSITE END



10

FOR 24962-CD, FASTEN CRANK-HANDLE TO LEG SHAFT
▲ PAGE 17 - ITEMS 8, 9, 10, 11, & 12

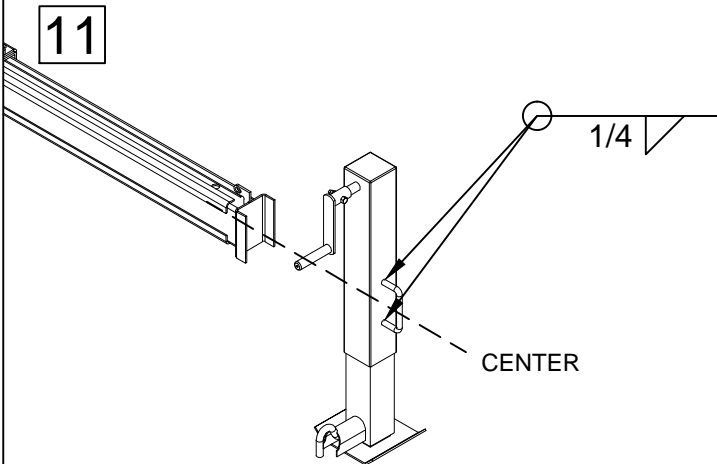

11

PROCEED TO 'MOUNTING THE OUTRIGGER LEGS'
WELD C-HANDLES CENTER TO PULLOUTS

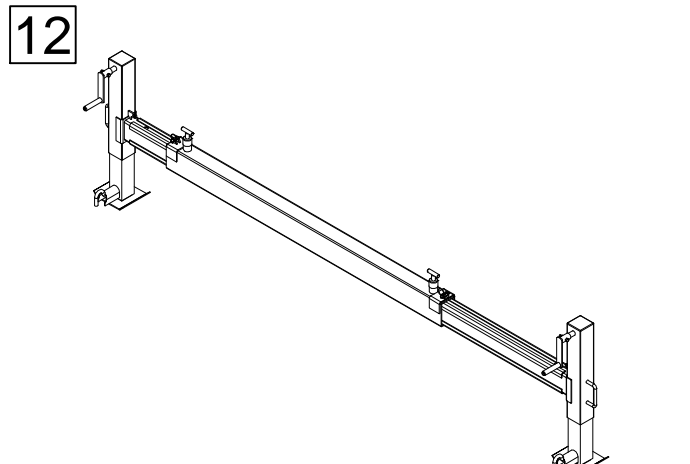

12

END OF 24962-CD-LC ASSEMBLY STEPS
PROCEED FOR ADDITIONAL 24962-PH-LC STEPS



VENCO VENTURO INDUSTRIES LLC
CINCINNATI, OHIO

LESS-CROSSTUBE ASSY ▲

24962-CD/PH OUTRIGGERS ▲

DATE
01-31-17A

SUPERSEDES
06-06-16

PAGE
15 ▲

24869

ASSEMBLY OF 24962-PH OUTRIGGER WITH LESS-CROSSTUBE CONFIGURATION



13

FASTEN BULKHEAD FITTINGS, EACH SIDE
PAGE 19 - ITEM 9



14

FASTEN REMAINING BULKHEADS, STRAIGHT ENDS INSIDE
▲ REFER TO 'HYDRAULIC MAPPING' FOR NEXT STEPS



15

INSTALL HOSES, ROUTE THROUGH UNDERCARRIAGE
PAGE 19 - ITEM 10



16

INSTALL HOSES, REFER TO 'HYDRAULIC MAPPING'
PAGE 19 - ITEMS 10 & 13



17

INSTALL HOSES FOR THE OTHER SIDE
PAGE 18 - ITEMS 11 & 12



18

INSTALL HOSES, REFER TO 'HYDRAULIC MAPPING'
PAGE 19 - ITEM 14



VENCO VENTURO INDUSTRIES LLC
CINCINNATI, OHIO

LESS-CROSSTUBE ASSY

24962-PH OUTRIGGERS

DATE
01-31-17A

SUPERSEDES
06-06-16

PAGE
16

24870

WELD DETAIL FOR HYDRAULIC BULKHEADS

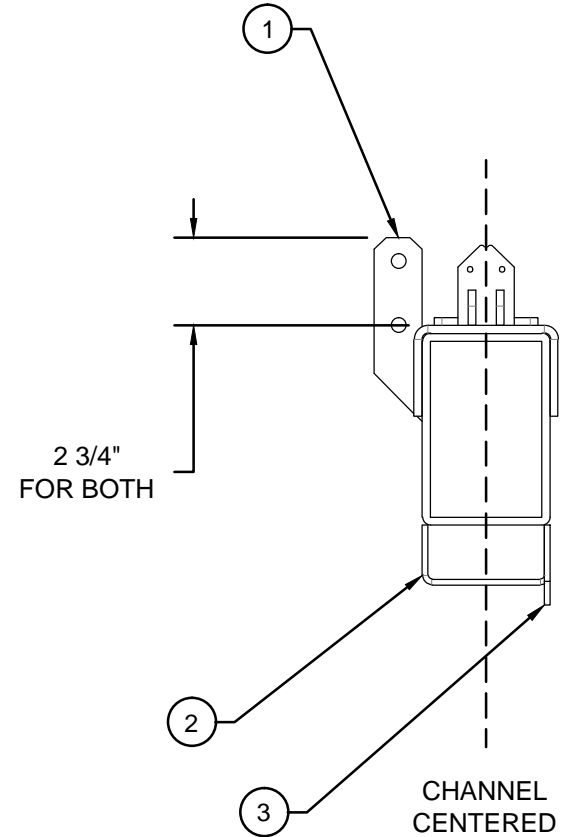
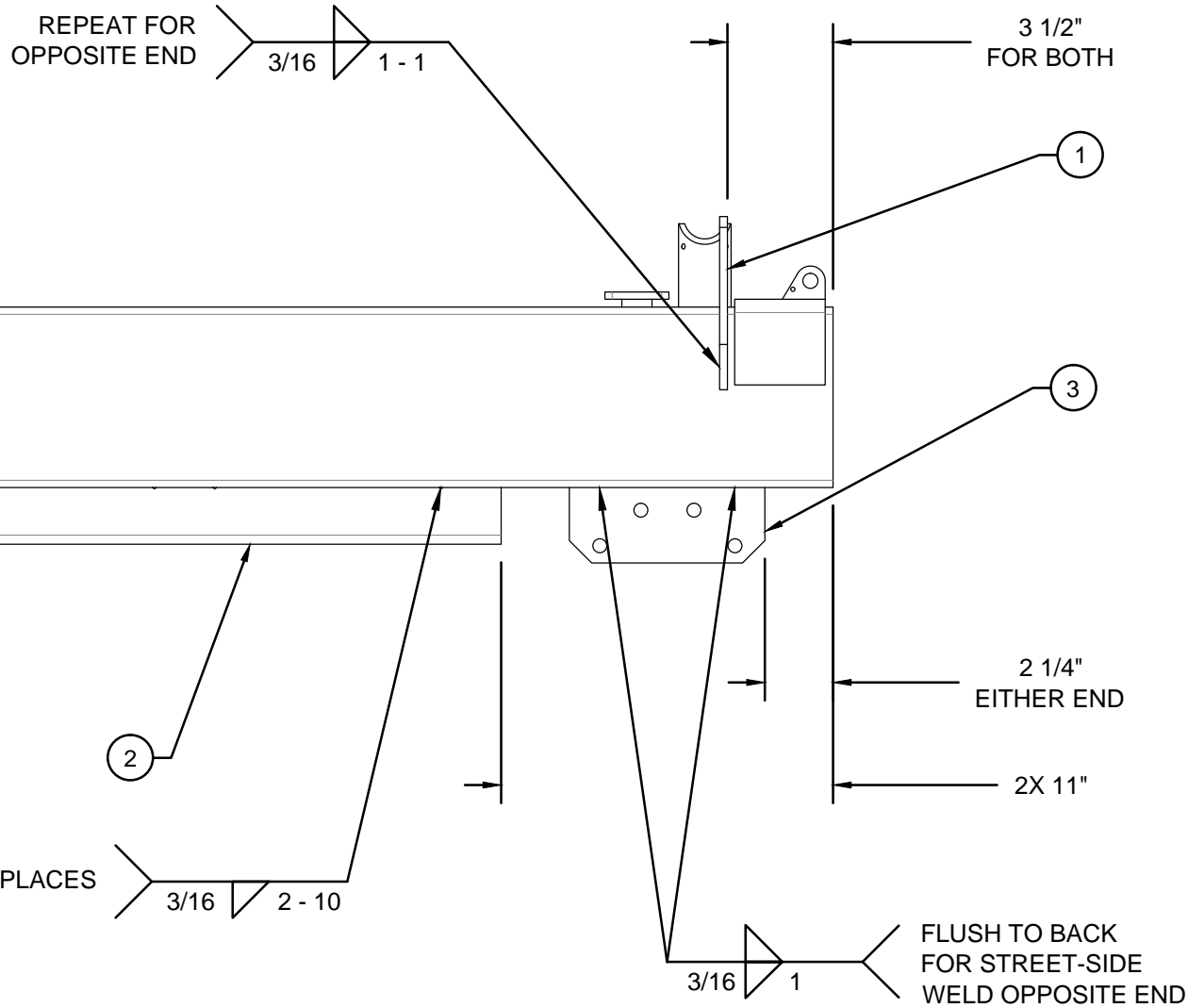

#	DESCRIPTION	QTY	PART #
1	SIDE BULKHEADS	2	22406
2	CHANNEL	1	22416
3	LOWER BULKHEAD	1	22405



VENCO VENTURO INDUSTRIES LLC
CINCINNATI, OHIO

TITLE
WELD DETAIL, HYDRAULIC BULKHEADS

24962-PH(E)-LC

DATE
03-12-21

SUPERSEDES
-

PAGE
25

24879

SECTION 400

REPLACEMENT PARTS



VENCO VENTURO INDUSTRIES LLC
CINCINNATI, OHIO

PARTS BREAKDOWN, 24962-CD OUTRIGGER (LESS-CROSSTUBE PARTS INCLUDED)

**24962-CD OUTRIGGER
PARTS BREAKDOWN
(LESS-CROSSTUBE PARTS INCLUDED)**

#	DESCRIPTION	QTY	PART #
1	PULLOUT; LONG, 3', RIGHT SIDE	1	22652
2	PULLOUT; SHORT, 1', LEFT SIDE	1	22422
3	C-HANDLE; MANUAL PULLOUT, LEG	2	19344
4	LOCK PIN; T-HANDLE, SPRING-LOADED	2	22668
5	ROLL PIN; 3/16 X 1-3/8, STAINLESS STEEL	4	!RPIN-019138-SS
6	SECURITY PIN; CLAMP RING, KEY-RING	2	24981
7	LEG; CRANK-DOWN, 24962 SERIES O.R.'S	2	25120
8	CRANK HANDLE; CRANK-DOWN, LEG	2	19009
9	HEX HEAD CAP SCREW; 5/16-18 X 1-3/4, GR. 5, ZINC	2	!HHCS03118175
10	LOCK WASHER; 5/16", GR. 5, ZINC	2	!LWSH-031
11	HEX NUT; 5/16-18, GR. 5, ZINC	2	!HNUT-03118
12	HANDLE GRIP; RED, RUBBER, CRANK-DOWN	2	16-00064
13	DECAL; DANGER, CRUSHING INJURY	2	24964
▲ 14	CROSSTUBE; 24962-CD OUTRIGGER	1	22425



VENCO VENTURO INDUSTRIES LLC
CINCINNATI, OHIO

PARTS BREAKDOWN ▲

24962-CD OUTRIGGER ▲

DATE
01-31-17A

SUPERSEDES
06-06-16

PAGE
17 ▲

24861

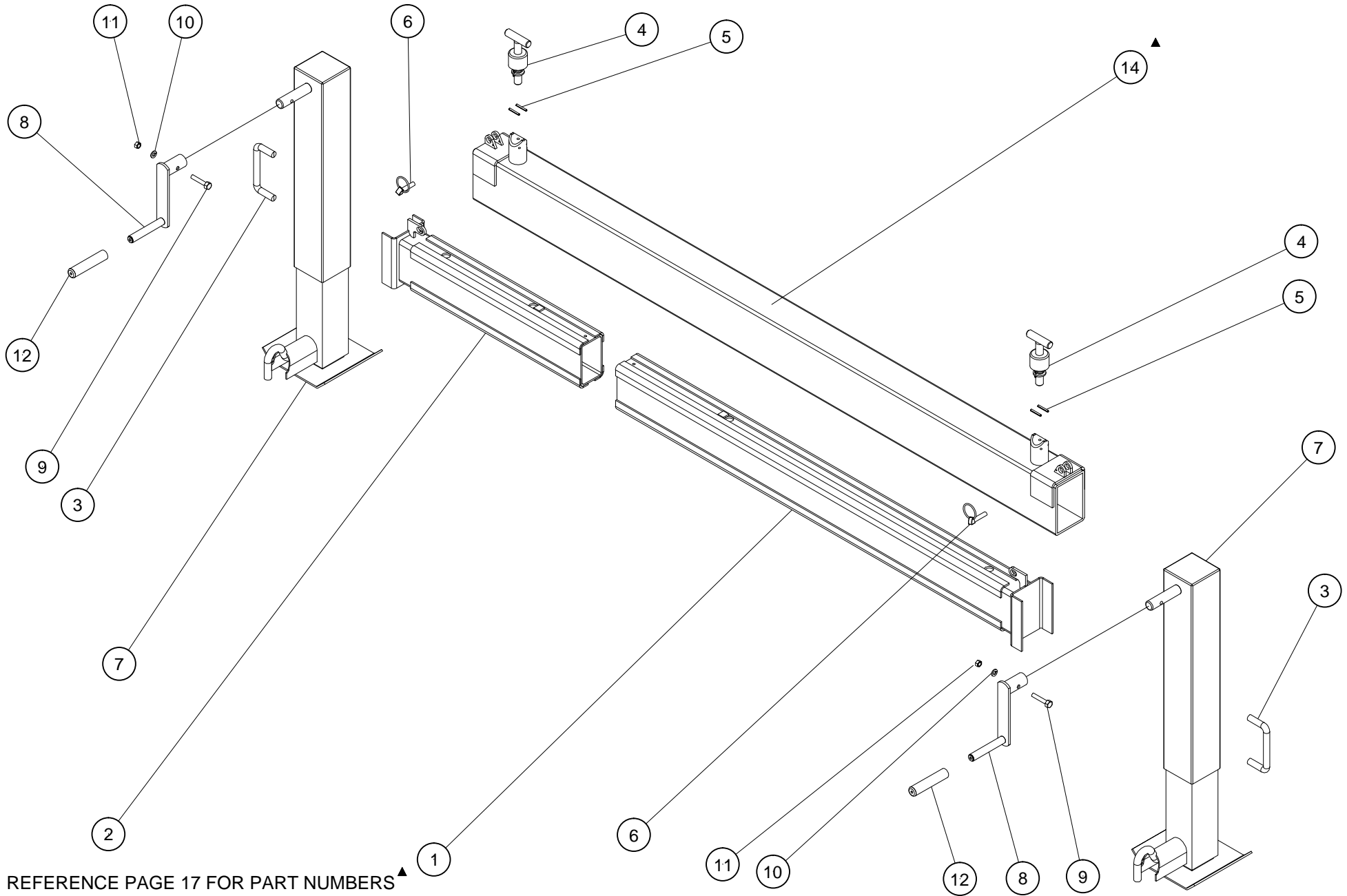

REFERENCE PAGE 17 FOR PART NUMBERS ▲



VENCO VENTURO INDUSTRIES LLC
CINCINNATI, OHIO

PARTS BREAKDOWN (LESS-CROSSTUBE PARTS INCLUDED)

24962-CD OUTRIGGER

▲ DATE
02-01-17A
▲ SUPERSEDES
06-06-16

PAGE
18
24862 ▲

PARTS BREAKDOWN, 24962-PH OUTRIGGERS (LESS-CROSSTUBE PARTS INCLUDED)

24962-PH OUTRIGGERS PARTS BREAKDOWN (LESS-CROSSTUBE PARTS INCLUDED)			
#	DESCRIPTION	QTY	PART #
1	PULLOUT; LONG, 3', RIGHT SIDE	1	22652
2	PULLOUT; SHORT, 1', LEFT SIDE	1	22422
3	C-HANDLE; MANUAL PULLOUT, LEG	2	19344
4	LOCK PIN; T-HANDLE, SPRING-LOADED	2	22668
5	ROLL PIN; 3/16 X 1-3/8, STAINLESS STEEL	4	IRPIN-019138-SS
6	SECURITY PIN; CLAMP RING, KEY-RING	2	24981
7	LEG; HYDRAULIC, LEFT SIDE	1	22465-1
8	LEG; HYDRAULIC, RIGHT SIDE	1	22465-2
9	FITTING; BULKHEAD, ELBOW, 90°, 4MJ-4MJ	8	H2701LN-0404
10	HOSE ASS'Y; CROSSOVER, LEFT LEG	2	22436
11	HOSE ASS'Y; CROSSOVER, RIGHT LEG	1	25018
12	HOSE ASS'Y; CROSSOVER, RIGHT LEG	1	22435
13	HOSE ASS'Y; PRESSURE/RETURN, LEFT LEG	2	22442
14	HOSE ASS'Y; PRESSURE/RETURN, RIGHT LEG	2	22443
15	HOSE ASS'Y; BULKHEAD TO VALVE BANK	4	22437
16	VALVE BANK; 2-SPOOL, FUNCTIONS	1	22444
17	FITTING; ADAPTER, STRAIGHT, 8MJ-8MO	2	H6400-0808
18	FITTING; ADAPTER, STRAIGHT, 4MJ-8MO	4	H6400-0408
19	SELECTOR VALVE; PRESSURE DIRECTION	1	27783
20	BRACKET; MOUNTING, SELECTOR VALVE	1	27784
21	DECAL; DANGER, CRUSHING INJURY	2	24964
22	CROSSTUBE; 24962-PH OUTRIGGERS	1	22637



VENCO VENTURO INDUSTRIES LLC
CINCINNATI, OHIO

PARTS BREAKDOWN

24962-PH OUTRIGGERS

DATE
02-01-17A

SUPERSEDES
06-06-16

PAGE

19

24863

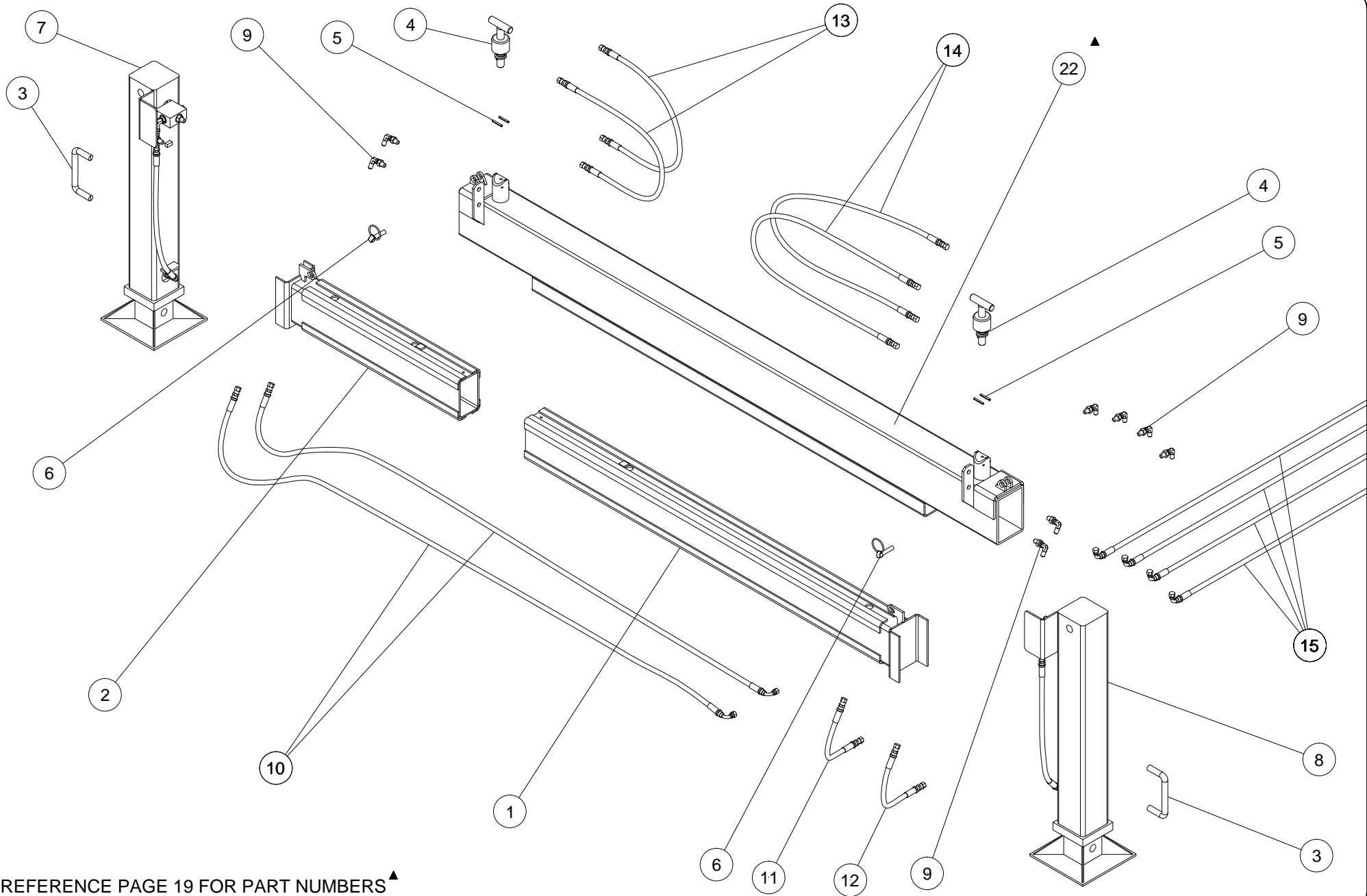

REFERENCE PAGE 19 FOR PART NUMBERS ▲



VENCO VENTURO INDUSTRIES LLC
CINCINNATI, OHIO

PARTS BREAKDOWN (LESS-CROSSTUBE PARTS INCLUDED)

24962-PH OUTRIGGERS

▲ DATE
02-01-17A
▲ SUPERSEDES
06-06-16

PAGE
20
24864 ▲

PARTS BREAKDOWN, 24962 SERIES HYDRAULIC LEGS ASSEMBLY

24962 SERIES HYDRAULIC LEGS ASSEMBLY PARTS BREAKDOWN		LEFT LEG	RIGHT LEG	LEFT LEG = 22465-1 RIGHT LEG = 22465-2
#	DESCRIPTION	QTY		PART #
1	LEG; LEFT SIDE, 24962 SERIES O.R.'S	1	-	22445-1
2	LEG; RIGHT SIDE, 24962 SERIES O.R.'S	-	1	22445-2
3	VALVE BLOCK; P.O. CHECK CARTRIDGE	1	1	22765-LF
4	FITTING; ADAPTER, STRAIGHT, 6MO-8MP	1	1	H6401-0608
5	FITTING; ADAPTER; STRAIGHT, 4MJ-6MO	1	1	H6400-0406
6	FITTING; ADAPTER, ELBOW, 90°, 6MO-4FX	1	1	HELB6MO-4FX-90
7	FITTING; ADAPTER, T-SHAPE, 4MJ-4MJ-4MP	1	1	HTEE4MJ-4MJ-4MP
8	HOSE ASS'Y; RETURN, LEG UP	1	1	24999
9	FITTING; ADAPTER, STRAIGHT, 4MO-4OFS	1	1	FF6400-0404



VENCO VENTURO INDUSTRIES LLC
CINCINNATI, OHIO

PARTS BREAKDOWN

24962 SERIES HYD. LEGS

DATE
02-01-17A

SUPERSEDES
06-06-16

PAGE
21

24865

LEFT HYDRAULIC LEG
22465-1

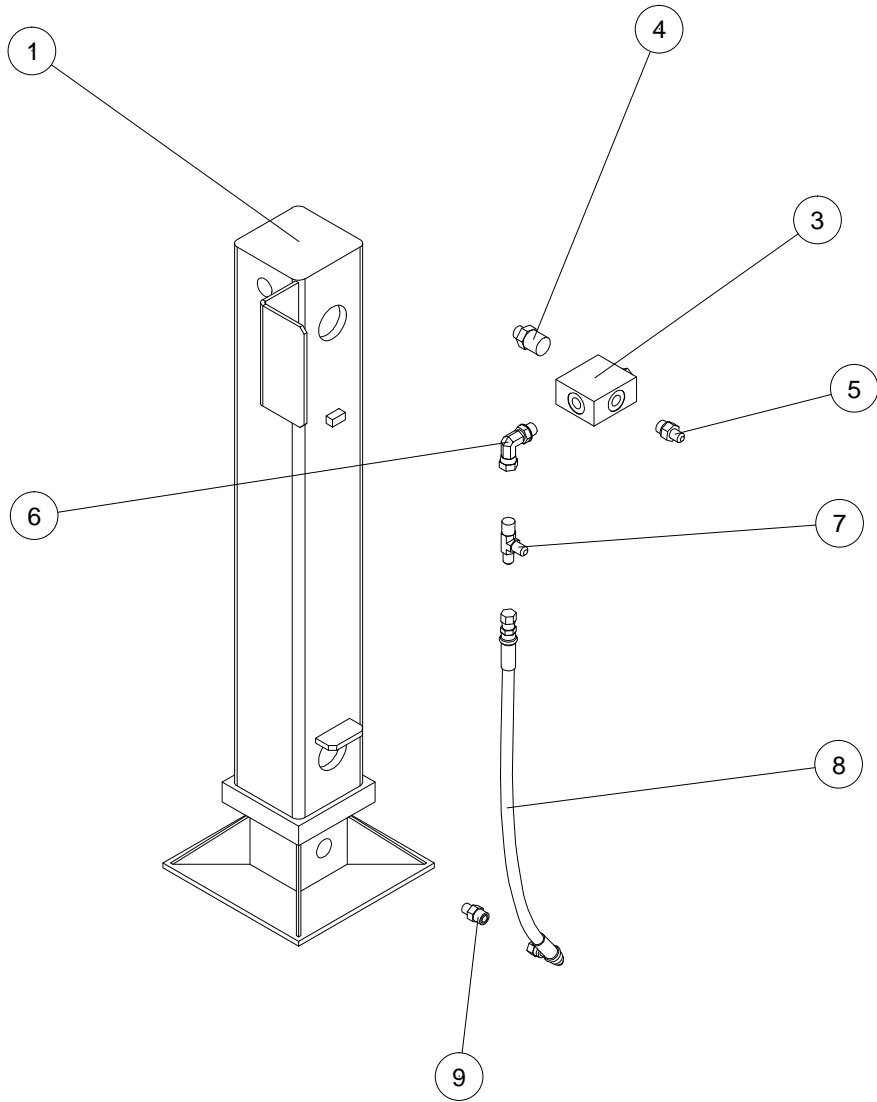

RIGHT HYDRAULIC LEG
22465-2

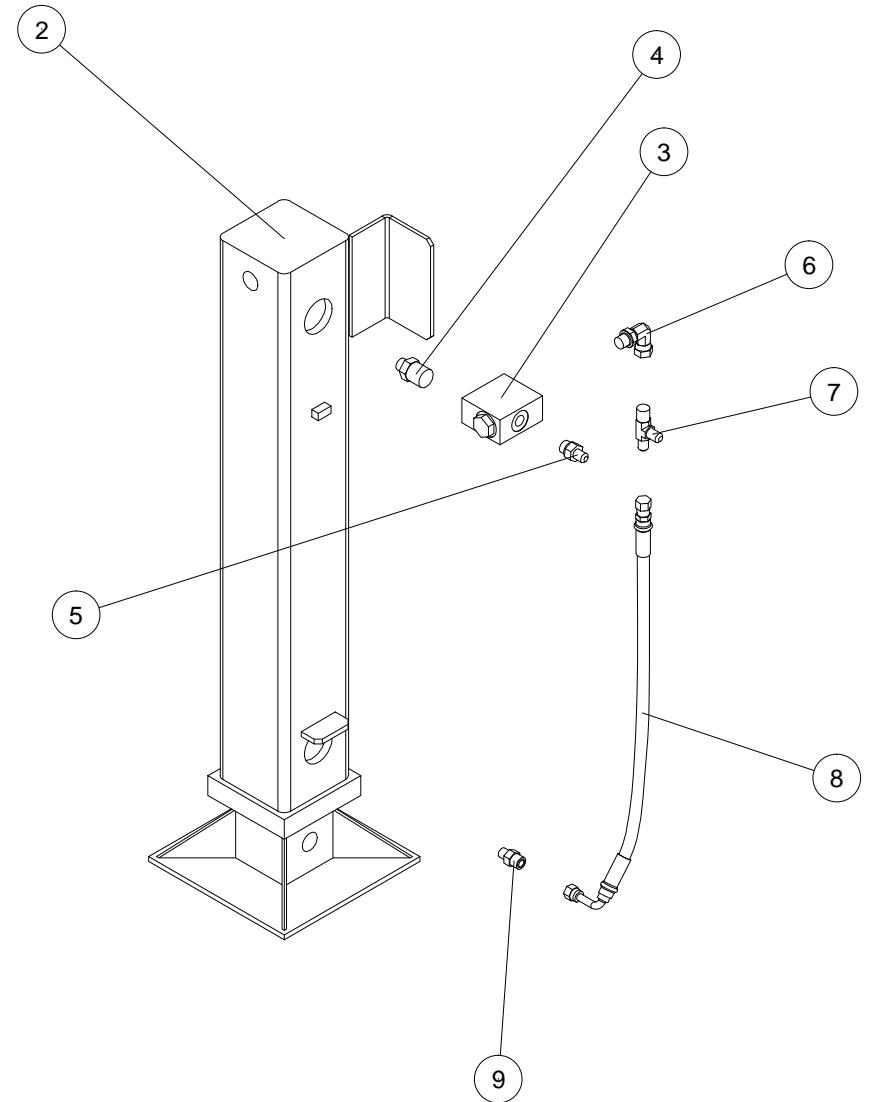

REFERENCE PAGE 21 FOR PART NUMBERS ▲



VENCO VENTURO INDUSTRIES LLC
CINCINNATI, OHIO

PARTS BREAKDOWN

24962 SERIES HYDRAULIC LEGS ASSEMBLY

▲	DATE	02-01-17A
▲	SUPERSEDES	06-06-16

PAGE	22
	24866

PHE OUTRIGGERS HYDRAULIC POWER UNIT & KIT (REF: 19401) PARTS BREAKDOWN			
#	DESCRIPTION	QTY	PART #
1	H.P.U. PUMP; PHE OUTRIGGERS	1	17260-1
2	HOSE ASSEMBLY; RETURN, 60", 8MO-8FJ	2	22438
3	ELBOW FITTING; 90°, 8MJ-6MP	1	H2501-0806
4	ELBOW FITTING; 90°, 8MJ-4MP	1	H2501-0804
5	CONTACTOR	1	15831C
6	SWITCH; MOMENTARY PUSH-BUTTON	1	17769
7	BRACKET; SWITCH, MOMENTARY PUSH-BUTTON	1	19402
8	BOOT COVER; MOTOR, H.P.U.	1	16143-3
9	BREATHER CAP; RESERVOIR, H.P.U.	1	19276
10	BOOT COVER; POSITIVE TERMINAL, MOTOR	1	18542
11	DECAL; OIL LEVEL	1	13397
12	BATTERY CABLE; 2 GA, 25' LONG, RED	1	01025-2*25FT
13	BATTERY CABLE; 2 GA, 18" LONG, RED	1	20133
14	GROUND CABLE; 2 GA, 18" LONG, BLACK	1	20133-1
15	WIRE; 16 GA, 20" LONG, #10 TERMINAL RINGS	1	20134
16	WIRE; 16 GA, 20" LONG, 5/16 RING, #10 RING	1	20134-1
17	WIRE; 16 GA, 18" LONG, 5/16 RING, #10 RING	1	20135
18	SPACER; 5/8" O.D., 12 GA DOM WALL, SS	2	19265
19	SPACER BLOCK; 3/4 X 1 X 2-3/8, 7/16" HOLES	1	17284
20	FLAT WASHER; 5/8", GR.5, ZINC, SAE	2	!FWSH-063SAE
21	HEX HEAD CAP SCREW; 3/8-16 X 2-1/4, GR. 5, ZINC	2	!HHCS03816225-5
22	HEX HEAD CAP SCREW; 3/8-16 X 1-1/4, GR. 5, ZINC	2	!HHCS03816125
23	LOCK WASHER; 3/8", GR. 5, ZINC	4	!LWSH-038
24	FLAT WASHER; 3/8", GR. 5, ZINC, SAE	6	!FWSH-038SAE
25	HEX NUT; 3/8-16, GR. 5, ZINC	2	!HNUT-03816
26	HEX HEAD CAP SCREW; 1/4-20 X 1, GR. 5, ZINC	4	!HHCS02520100-5
27	LOCK WASHER; 1/4", GR. 5, ZINC	4	!LWSH-025
28	FLAT WASHER; 1/4", GR. 5, ZINC	8	!FWSH-025
29	HEX NUT; 1/4-20, GR. 5, ZINC	4	!HNUT-02520
30	HEX HEAD CAP SCREW; 5/16-18 X 3/4, GR. 5, ZINC	1	!HHCS03118075
31	LOCK WASHER; 5/16", GR. 5, ZINC	1	!LWSH-031
32	STAR WASHER; 5/16", EXT STAR, STAINLESS STEEL	1	!LWSH-031-STAR-SS



VENCO VENTURO INDUSTRIES LLC
CINCINNATI, OHIO

PARTS BREAKDOWN

PHE H.P.U./KIT (REF: 19401)

DATE
02-01-17A

SUPERSEDES
06-06-16

PAGE

23

25465-1

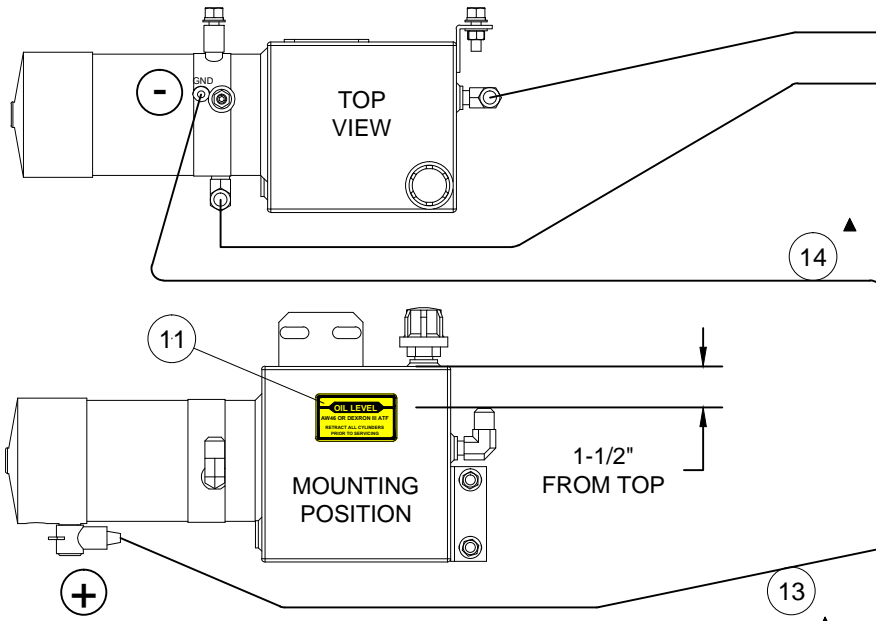

PARTS WITHOUT ITEM NUMBERS INCLUDED WITH COMPONENTS



22444 VALVE BANK

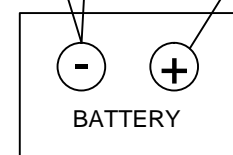
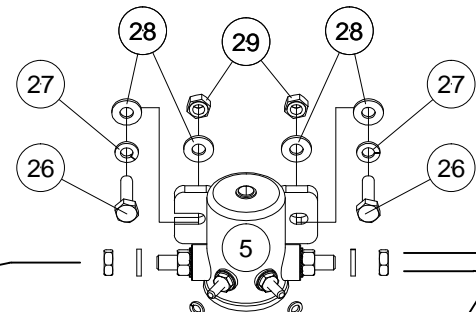

REFERENCE 'BATTERY CABLES & COMPONENTS INSTALLATION'

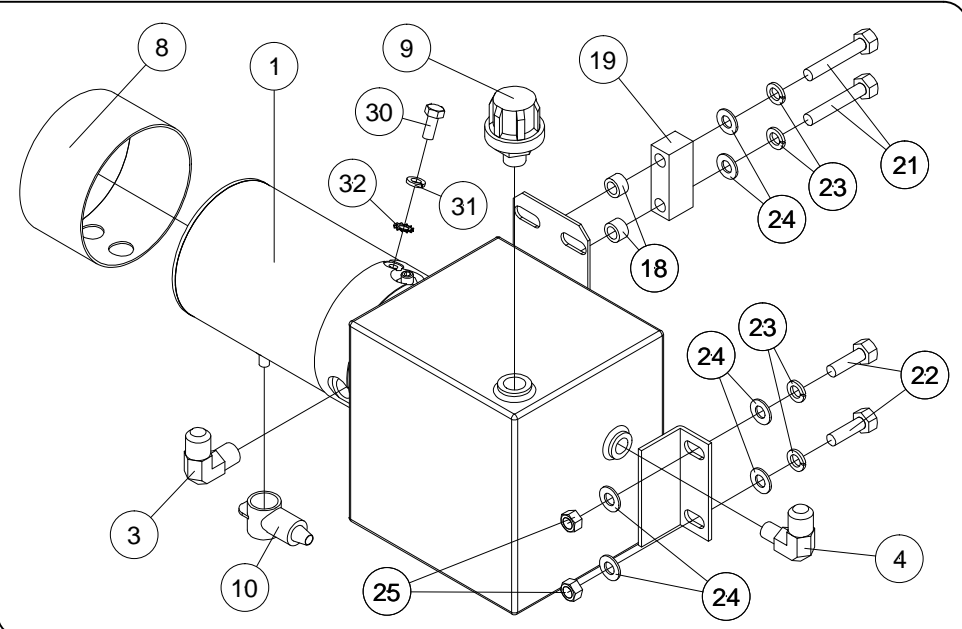
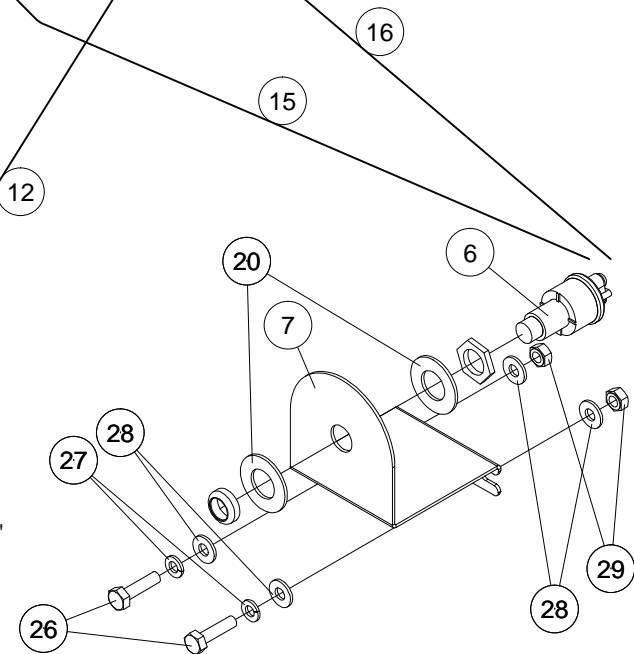

VENCO VENTURO INDUSTRIES LLC
CINCINNATI, OHIO

PARTS BREAKDOWN (REF: 19401)

PHE OUTRIGGERS HYDRAULIC POWER UNIT & KIT

▲ DATE
02-01-17B

▲ SUPERSEDES
06-13-16A

PAGE
24

25466-1

PHE OUTRIGGERS HYDRAULIC POWER UNIT & KIT (REF: 25477) PARTS BREAKDOWN			
#	DESCRIPTION	QTY	PART #
1	H.P.U. PUMP; PHE OUTRIGGERS	1	20456
2	HOSE ASSEMBLY; PRESSURE / RETURN, 60", 8MO-8FJ	2	22438
3	ELBOW FITTING; 90°, 8MJ-6MP	1	H2501-0806
4	ELBOW FITTING; 90°, 8MJ-4MP	1	H2501-0804
5	SWITCH; MOMENTARY PUSH-BUTTON	1	17769
6	BRACKET; SWITCH, MOMENTARY PUSH-BUTTON	1	19402
7	BREATHER CAP; RESERVOIR, H.P.U.	1	19276
8	DECAL; OIL LEVEL	1	13397
9	BATTERY CABLE; 2 GA, 25' LONG, RED	1	01025-2*25FT
10	GROUND CABLE; 2 GA, 18" LONG, BLACK	1	20133-1
11	WIRE; 16 GA, 20" LONG, #10 TERMINAL RINGS	1	20134
12	WIRE; 16 GA, 20" LONG, 5/16 RING, #10 RING	1	20134-1
13	FLAT WASHER; 5/8", GR.5, ZINC, SAE	2	!FWSH-063SAE
14	HEX HEAD CAP SCREW; 1/4-20 X 1, GR. 5, ZINC	2	!HHCS02520100-5
15	LOCK WASHER; 1/4", GR. 5, ZINC	2	!LWSH-025
16	FLAT WASHER; 1/4", GR. 5, ZINC	4	!FWSH-025
17	HEX NUT; 1/4-20, GR. 5, ZINC	2	!HNUT-02520



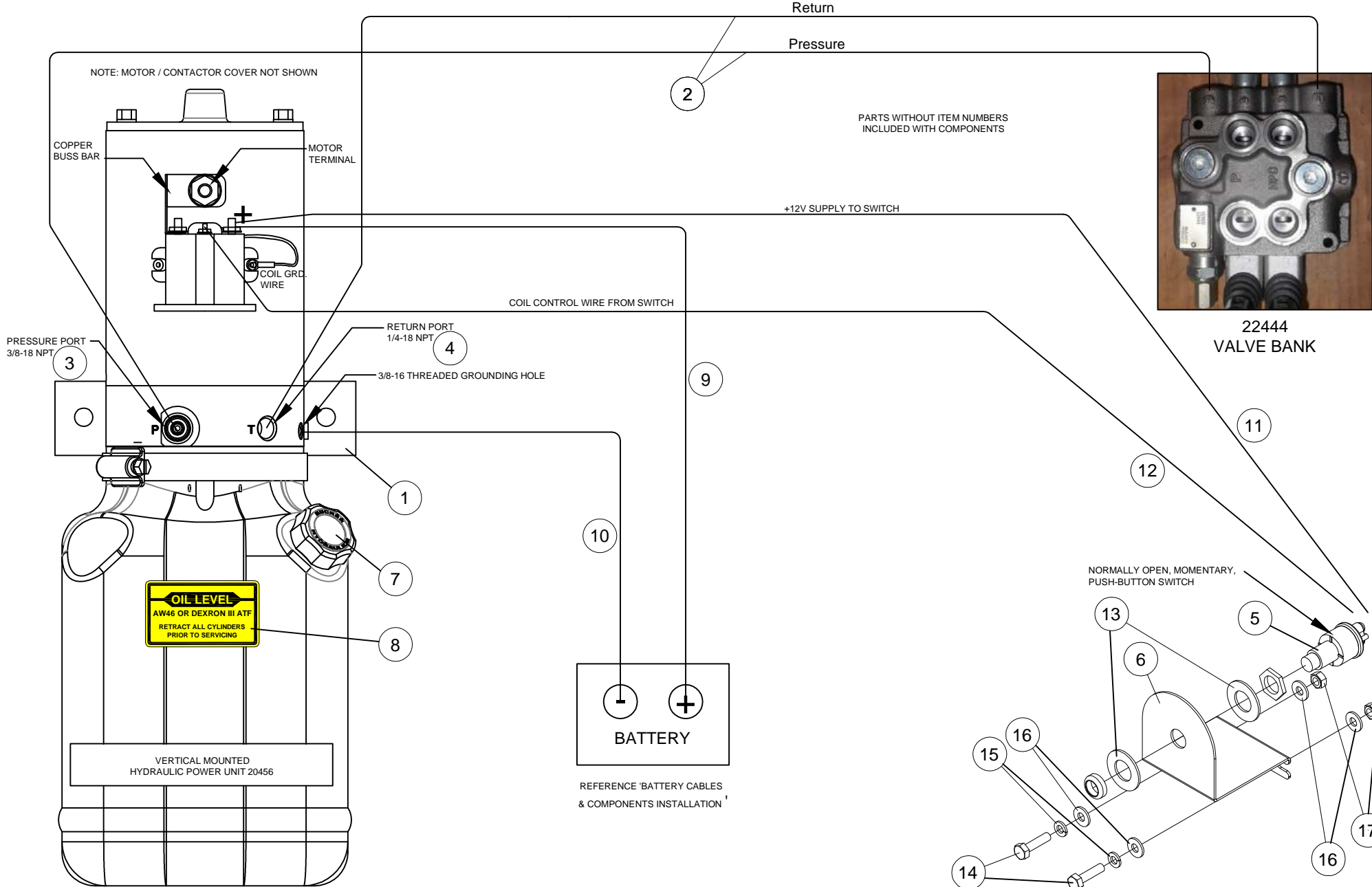



VENTURO CRANES LIMITED WARRANTY POLICY

Venturo products are built to last...we guarantee them.

As a purchaser of any new Venturo product covered by warranty, you will receive 1 year of the most complete coverage available...and, at no added cost to you.

1-Year Limited Warranty Policy

This limited policy warrants new products of Venturo to be free from defects in material and workmanship for a period of one (1) year from date of original installation. OEM products or accessories purchased by Venturo as part of or offered with our product will carry the OEM manufacturer's respective warranty. Our warranty covers:

- ***Repair or replacement of product***
- ***Labor to repair or replace product***
- ***Freight to return and/or replace product***

We shall not be liable for any contingent liabilities arising out of the improper function of any products. Warranty shall become void if the product is improperly installed, modified, damaged, abused or used for application other than intended use. There is no warranty of merchantability, fitness for a particular purpose, warranty arising from course of dealing or usage of trade, or any other implied or expressed warranty, except as made specifically herein. This warranty supersedes all previous warranties, written or implied.

Warranty Claims

Venco Venturo Industries LLC will make a good faith effort for prompt correction or other adjustment with respect to any product, which proves to be defective after our inspection and within the warranty period. Before any repairs are attempted or before returning any product, your Venturo Distributor is required to obtain a warranty claim number. This number is necessary for any claim to be considered. To obtain a warranty claim number, Venturo requires the model and serial number. Only authorized Venturo Distributors can perform warranty. For the name and address of your local Venturo Distributor call the **Warranty Claim Department - 513-772-8448**.

WARNING - It is the responsibility of the installer to ensure the installation is completed according to the manufacturer's recommendations, ensure the ultimate user understands how to operate product in a safe manner, and understands the need for regular service and maintenance by an authorized Venturo Distributor. No modifications or alterations may be made to any Venturo product without the expressed written consent of Venco Venturo Industries LLC. Installation of any Venturo product must be done by an authorized Venturo Distributor, to the standards of the industry; including maintenance, service and affixing of all instruction, safety and warning decals. Users should be instructed as to the safe operation at time of delivery. Maintenance, service, operation and safety warning decals are available on request from Venco Venturo Industries LLC.

VENCO VENTURO INDUSTRIES LLC
12110 BEST PLACE | CINCINNATI, OHIO 45241
P: 800-226-2238 | F: 513-326-5427
www.venturo.com