



OWNER'S MANUAL

PARTS & INSTALLATION MANUAL

VC6628

Included in this manual:

VC6628

- Capacity & Application Charts

VENCO VENTURO INDUSTRIES LLC
12110 BEST PLACE | CINCINNATI, OHIO 45241
800-226-2238



This manual also available online at www.venturo.com.

VC6628

INST-662874 - 7/16/2024 (Rev: A4)

520951	INSTALLATION WARNINGS
520952	OPERATOR WARNINGS
516913	SECTION 200: INSTALLATION
662851	CAPACITY CHART, VC6628
662867	VC6628 MOUNTING DIMENSIONS
662864	HOIST LIFTING HOLE LOCATIONS
416086	IMPORTANT INSTALLATION NOTICE
662871	HOIST MOUNTING INSTRUCTIONS
662872	HOIST MOUNTING INSTRUCTIONS
662873	HOIST MOUNTING INSTRUCTIONS
520093	INSTALLATION INSTRUCTIONS
628861	HINGE TO BED MOUNTING INSTRUCTIONS
620246	CABLE / HANDLE ASSEMBLY
416755	PTO PUMP CABLE INSTALLATION
416763	SPLIT PUMP
416812	BI-ROTATIONAL PUMP INSTALLATION
552004	SPDG HOSE CONNECTION DIAGRAM
416287	WILLIAMS PTO WARNING
416128	DECAL LOCATIONS
516917	SECTION 250: OPERATION
520079	MAINTENANCE & OPERATION INSTRUCTIONS
416644	BODY PROP OPERATION GUIDE, GENERAL
628645	BODY PROP OPERATION GUIDE, ILLUSTRATIONS / INSTRUCTIONS
516914	SECTION 300: MAINTENANCE
662124	VC6620/6628 HOISTS GREASE POINTS
516915	SECTION 400: REPLACEMENT PARTS
628820	DECAL LIST
662853	REPLACEMENT PARTS DWG, VC6628 HOIST
662854	REPLACEMENT PARTS LIST, VC6628 HOIST
620245	REPLACEMENT PARTS DIAGRAM, PTO PUMP CABLE/CONSOLE
516919	USER NOTES
516919	USER NOTES
12-00073_VNC3	WARRANTY PAGE

READ THIS FIRST - INSTALLATION

USE THE BODY PROP

- ▶ NEVER work under a raised body without the use of the body prop. Body could inadvertently fall, causing death or serious injury.
- ▶ NEVER perform maintenance on a Hoist without applying the following:
 - ▶▶ Chassis brake set and engine turned off
 - ▶▶ Removing battery cable, if necessary
 - ▶▶ Properly deploying the Hoist body prop



INSTALLATION SAFETY REQUIREMENTS

- ▶ Cover all fuel related items (hoses, brake lines, wiring, etc.) so as not to cause fire or explosions that will result in serious injury or death.
- ▶ Route all wiring and hoses away from exhaust systems. Heat from exhaust systems can cause melting of wiring and hoses, resulting in fire and/or explosions that could result in serious injury or death.
- ▶ Hydraulic system must be designed to work within the manufacturer's specifications. Systems with more flow or PSI can cause hoist to fail during the dumping of a load; which could cause damage, serious injury or death.
- ▶ Always wear eye protection and protective clothing when working around hydraulic systems. Fluid under pressure can pierce the skin and enter the bloodstream, causing serious injury or death.

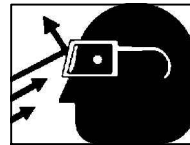

IMPORTANT INSTALLATION REQUIREMENTS

- ▶ Read and fully understand entire owner's manual prior to installation.
- ▶ Refer to Body Builder's Guide BEFORE welding or drilling on chassis as not to void the chassis warranty.
- ▶ When drilling the chassis make sure all brake lines, wire harnesses, and hoses are protected so as not to cause damage to these items resulting in failure. All fasteners must be installed so they do not interfere with these items as well.
- ▶ NEVER adjust factory relief valve settings without consulting with the factory.



VENCO VENTURO INDUSTRIES LLC
CINCINNATI, OHIO

TITLE
INSTALLATION WARNINGS

HOISTS

DATE
12-11-23C

SUPERSEDES
11-07-23B

SECTION

-
520951

READ THIS FIRST - OPERATION

USE THE BODY PROP

- ▶ When performing maintenance, truck should be turned off and the emergency brake set along with the body prop set under an UNLOADED body. NEVER prop a loaded body. Body could inadvertently fall, causing death or serious injury.
- ▶ NEVER work under a raised body without the use of the body prop. Body could inadvertently fall, causing death or serious injury.

! DANGER

WILL RESULT IN SERIOUS INJURY
OR DEATH



DUMP SAFETY

- ▶ Overloading Hoist can cause equipment malfunction, which will cause serious injury or death.
- ▶ Venco hoists are designed for and intended to be used on stationary trucks, dumping on firm and level ground. Spreading applications and/or shock-unloading are strictly prohibited. Failure to follow these guidelines could result in serious injury or death.
- ▶ Do not dump while on uneven ground or if vehicle is uneven side to side. Dumping while uneven can cause vehicle to overturn and cause property damage, equipment damage, serious injury or death.
- ▶ Stay clear of dump body when dumping. Moving vehicle parts or the moving load could cause serious injury or death.
- ▶ NEVER operate this Hoist from outside the cab. This could cause serious injury or death.

! WARNING

CAN RESULT IN SERIOUS INJURY
OR DEATH



UNDERSTAND YOUR EQUIPMENT

- ▶ Read and fully understand entire owner's manual prior to operating this equipment.
- ▶ Only allow qualified personnel to work on this equipment that understands its functions.
- ▶ Make sure all warning and caution labels are legible and properly placed. Refer to the installation section for placement and the replacement parts section for replacement decals.
- ▶ We strongly recommend you contact your truck equipment distributor to perform any type of repair or maintenance on your equipment. If you do not have a local distributor, call VENCO VENTURO INDUSTRIES LLC for the closest authorized distributor.

! CAUTION

COULD RESULT IN MINOR OR
MODERATE INJURY



VENCO VENTURO INDUSTRIES LLC
CINCINNATI, OHIO

TITLE
OPERATOR WARNINGS

DATE
12-11-23B

SECTION
-

HOISTS

SUPERSEDES
11-07-23A

520952

SECTION 200

INSTALLATION



VENCO VENTURO INDUSTRIES LLC
CINCINNATI, OHIO

VENCO HOIST MODEL VC6628

CAPACITIES ARE BASED ON WATER LEVELS AND NON-DIMINISHING LOADS. DUE TO THE VARIATIONS IN TRUCK EQUIPMENT AND CAB-AXLE LENGTHS (CA), THE DATA PROVIDED ON THIS PAGE IS TO BE USED AS A GUIDELINE ONLY.

DUMP CLASS: 90

CONVERSION CLASS: J

WEIGHT: 1200 LBS.

POWER SOURCE:

PD - POWER TAKE OFF DOUBLE ACTING



ADDITIONAL DATA:

DUAL CYLINDERS, 6" BORE x 28" STROKE

CA: 138"-252"

CT: 126"-240"

DUMP ANGLE: 40° - 50°



CONVERSION APPLICATIONS VC6628					
BODY	CA	CT	O.H.	45° (TON)	50° (TON)
18'	138"	126"	48"	35.7	32.4
18'	144"	132"	42"	32.4	29.4
18'	150"	138"	36"	29.7	27.0
18'	156"	144"	30"	27.4	24.9
18'	162"	150"	24"	25.5	23.1
18'	168"	156"	18"	23.8	21.6
18'	174"	162"	12"	22.3	20.2
18'	180"	168"	6"	21.0	19.0
20'	162"	150"	48"	29.7	27.0
20'	168"	156"	42"	27.4	24.9
20'	174"	162"	36"	25.5	23.1
20'	180"	168"	30"	23.8	21.6
20'	186"	174"	24"	22.3	20.2
20'	192"	180"	18"	21.0	19.0
20'	198"	186"	12"	19.8	18.0
20'	204"	192"	6"	18.8	17.0
22'	186"	174"	48"	25.5	23.1
22'	192"	180"	42"	23.8	21.6
22'	198"	186"	36"	22.3	20.2
22'	204"	192"	30"	21.0	19.0
22'	210"	198"	24"	19.8	18.0
22'	216"	204"	18"	18.8	17.0
22'	222"	210"	12"	17.8	16.2
22'	228"	216"	6"	17.0	15.4
24'	210"	198"	48"	22.3	20.2
24'	216"	204"	42"	21.0	19.0
24'	222"	210"	36"	19.8	18.0
24'	228"	216"	30"	18.8	17.0
24'	234"	222"	24"	17.8	16.2
24'	240"	228"	18"	17.0	15.4
24'	246"	234"	12"	16.2	14.7
24'	252"	240"	6"	15.5	14.1

DUMP BODY APPLICATIONS VC6628 *					
BODY	CA	CT	O.H.	45° (TON)	50° (TON)
12'	102"	90"	12"	35.7	32.4
13'	114"	102"	12"	32.4	29.4
14'	126"	114"	12"	29.7	27.0
15'	138"	126"	12"	27.4	24.9
16'	150"	138"	12"	25.5	23.1
18'	174"	162"	12"	22.3	20.2

* VENCO hoists are designed for and intended to be used on stationary trucks dumping on firm and level ground. Spreading applications and/or shock unloading are strictly prohibited and will void the warranty. ▲



VENCO VENTURO INDUSTRIES LLC
CINCINNATI, OHIO

TITLE
CAPACITY CHART

VC 6628 HOIST

DATE
07-16-24E

SUPERSEDES
01-23-15D

SECTION
H100

662851

VC6628 HOIST MOUNTING DIMENSIONS

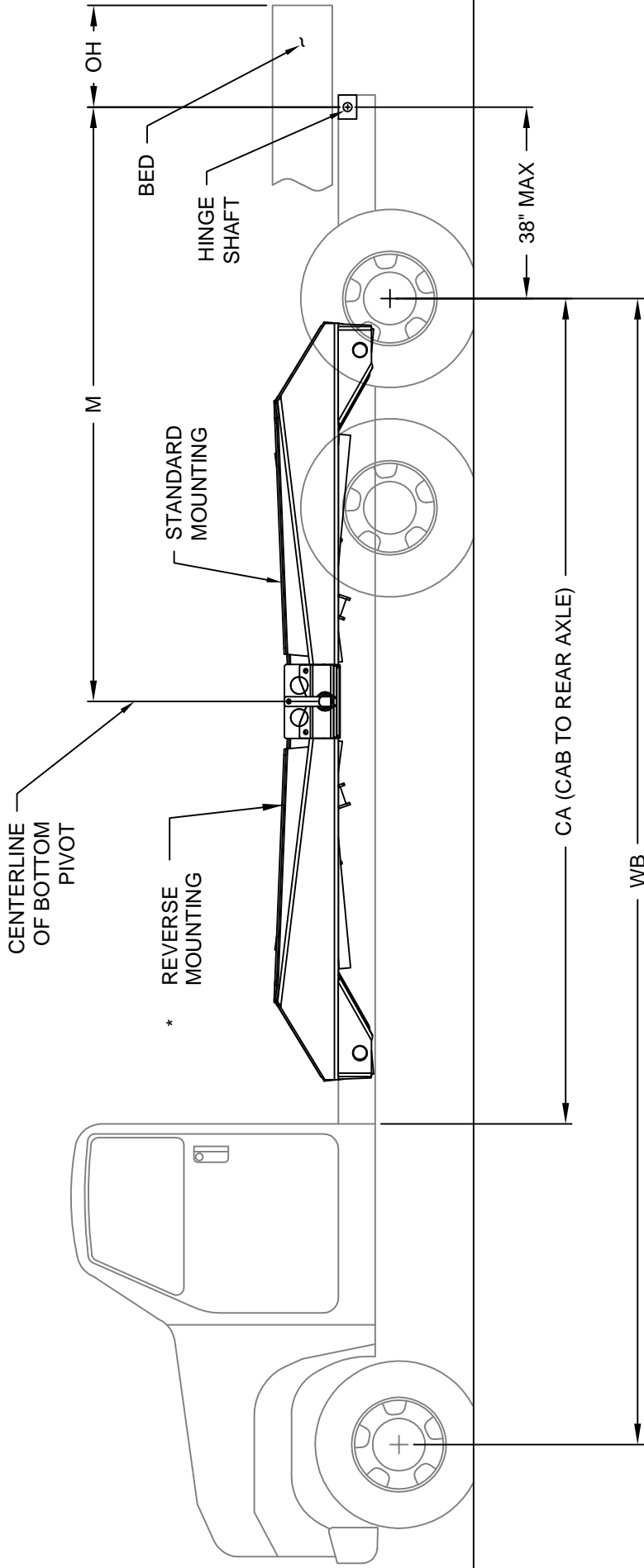

STANDARD MOUNTING

DUMP ANGLE	M
40°	146"
45°	130-1/2"
50°	118-1/4"

*REVERSE MOUNTING

DUMP ANGLE	M
40°	140"
45°	129"
50°	115"

FIGURE 1.C



VENCO VENTURO INDUSTRIES LLC
CINCINNATI, OHIO

TITLE

MOUNTING DIMENSIONS

VC6628

DATE

10-05-16A

SUPERSEDES

12-16-15

SECTION

H200

662867

LIFTING HOLE LOCATIONS

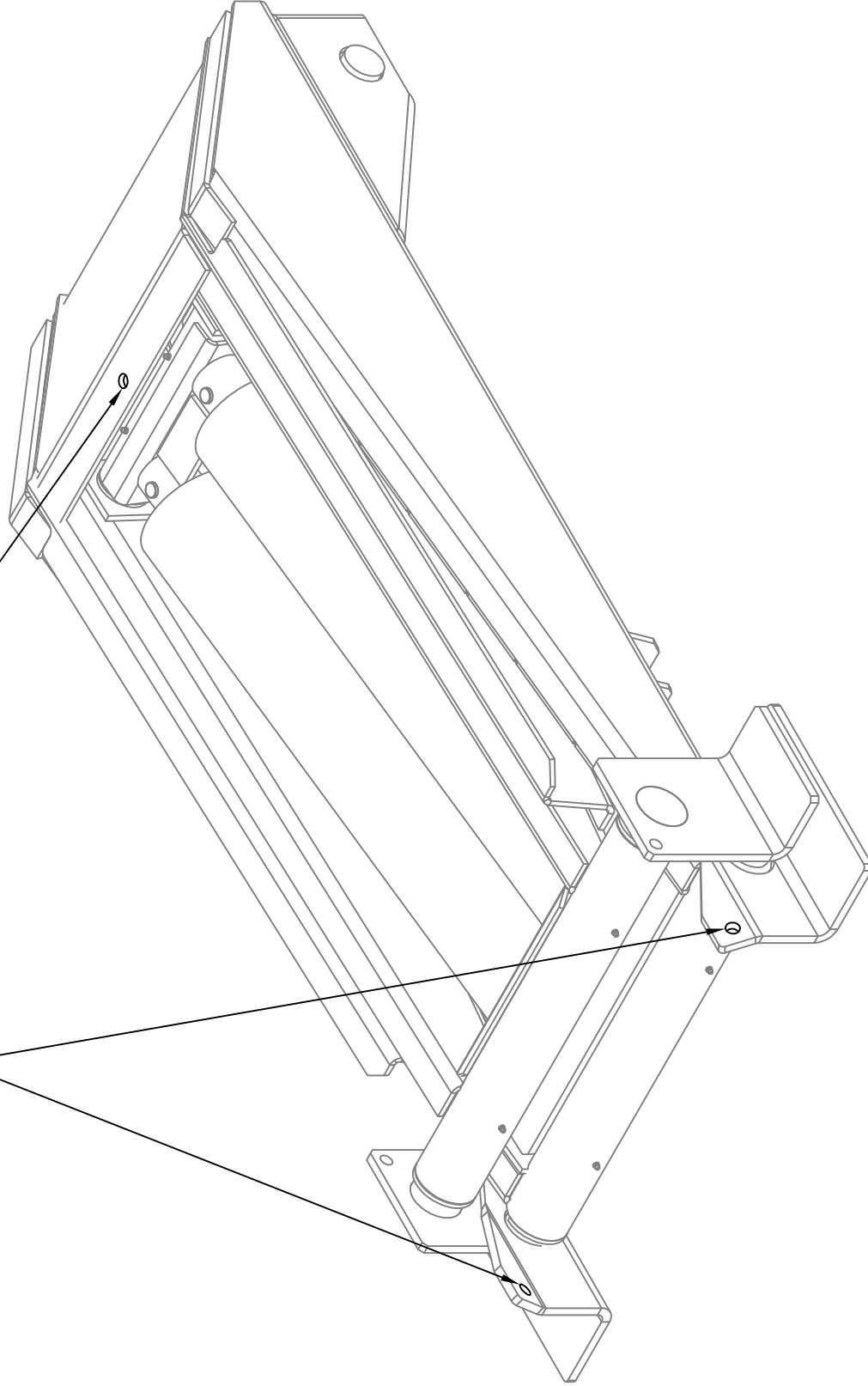

VENCO VENTURO INDUSTRIES LLC
CINCINNATI, OHIO

TITLE
HOIST LIFTING HOLE LOCATIONS

VC6628

DATE
12-17-15B
SUPERSEDES
03-11-05A

SECTION
-

662864

!! IMPORTANT WARNING !!

* ALL VENCO CONVERSION HOISTS → VC416 THRU VC6628 *

1

When installing the hoist, be sure to keep the hoist on a horizontal plane - LEVEL - with the truck frame.

VC416 / VC516

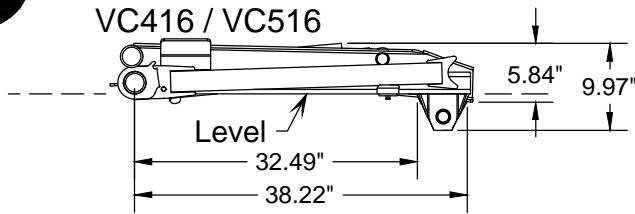

VC628

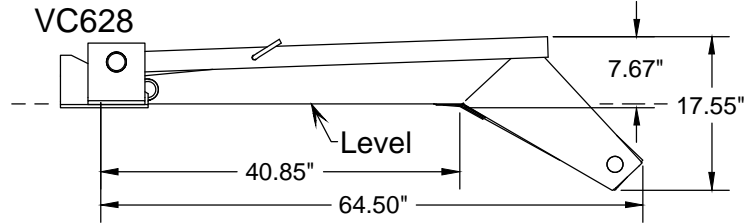

VC520 / VC620 (620200)

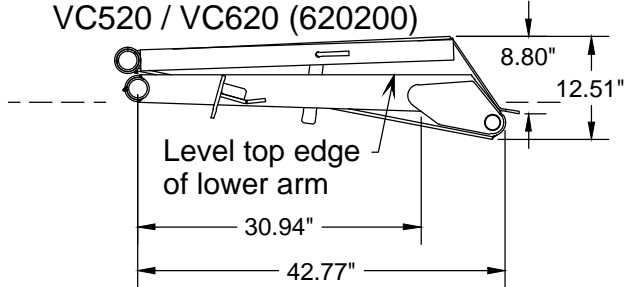

VC5520 / VC6620

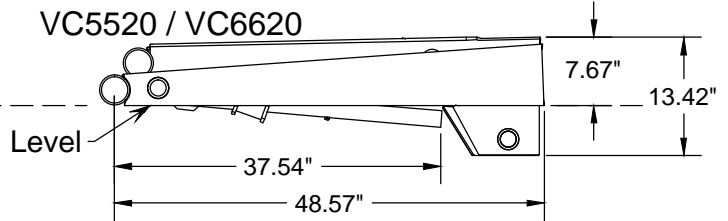

VC6628

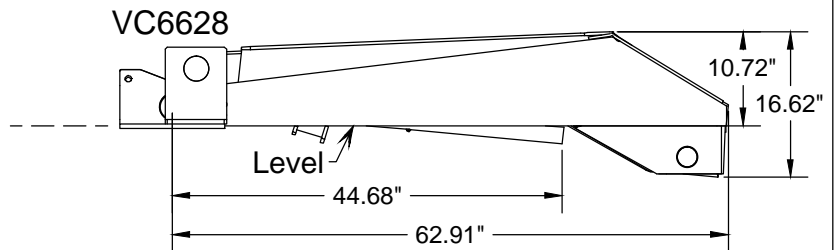

2

!! IMPORTANT !!

A minimum clearance of 2" is required between the hoist (upper arm) and the body cross-members in order to prevent a mechanical lockout. If clearance is less than 2", then cross-members must be notched above arms.

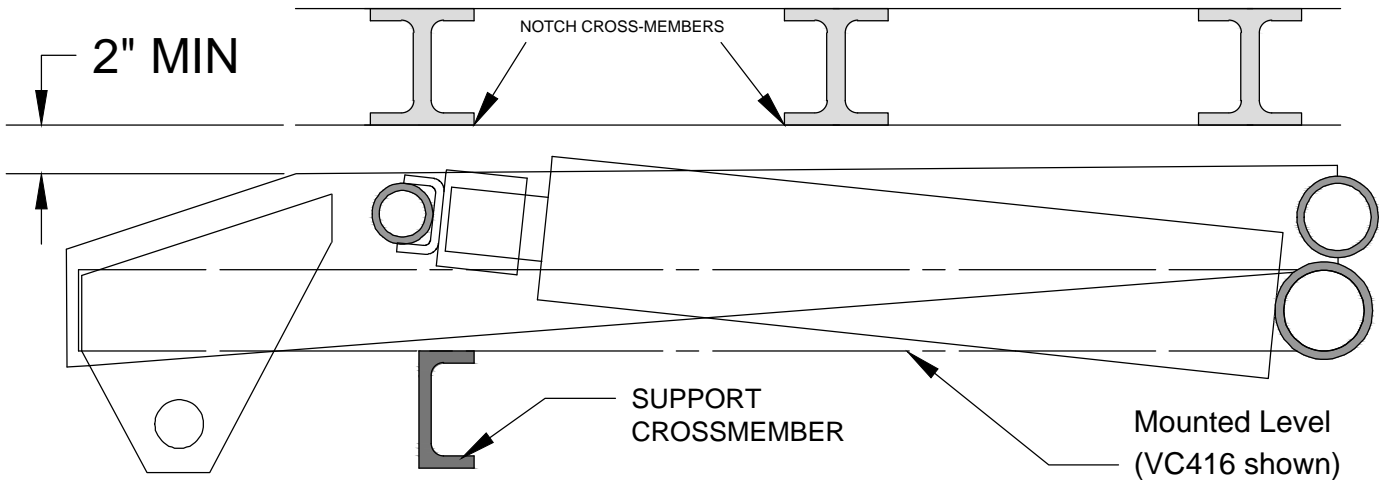

!! IMPORTANT !!
 THE HOIST SCISSOR MUST BE SUPPORTED WITH A CHASSIS-MOUNTED SUPPORT CROSSMEMBER. IF THE TRUCK CHASSIS DOES NOT HAVE A CROSSMEMBER TO SUPPORT THE HOIST IN A 'LEVEL' POSITION, THE INSTALLER 'MUST' INSTALL A SUPPORT CROSSMEMBER AS SHOWN ABOVE.



VENCO VENTURO INDUSTRIES LLC
 CINCINNATI, OHIO

TITLE	DATE	SECTION
IMPORTANT WARNING	12-08-20P	H200
VENCO HOISTS	SUPERSEDES 11-05-15N	416086

HOIST MOUNTING INST. - VC6628

Refer to Capacity Chart drawing 662851.



CAUTION



- If the distance between the center of the rear axle and the rear hinge assembly exceeds 38", additional reinforcement of the truck frame is necessary

- Mark the location for the rear hinge. Ideally, this location will be immediately behind a truck cross member, approximately 38" behind the center of the rear axle on a single axle truck (see drawing 662867).
- Cut a 90° slot in each side of the frame as shown in Figure 2 below.
- Position the angle iron frame of the rear hinge assembly in the truck frame cut-outs. Make sure the rear hinge assembly is properly positioned on the truck frame. Weld all around truck frame rear hinge assembly joint (both sides). See DWG 628861 for information regarding the mounting of the Rear Hinge Brackets to the body.

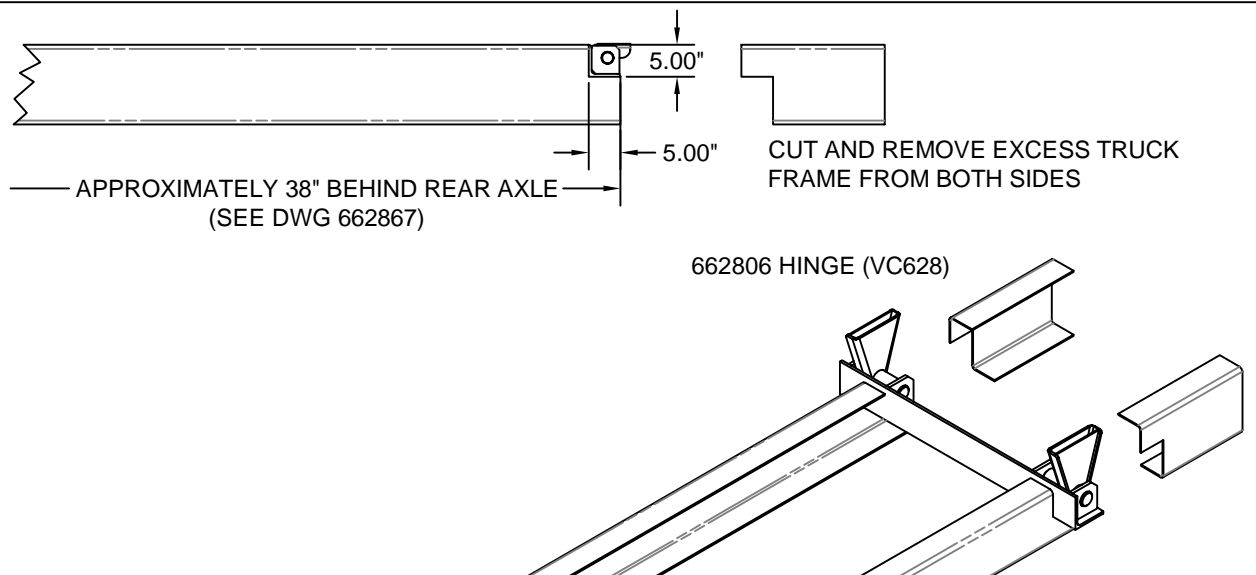

Figure 2 - Frame Modification and Rear Hinge Attachment

- Locate the hoist on the truck frame, making sure to center and square the hoist to the truck frame. The VC hoist is designed to rest on the truck frame. A section of the hoist extends below the truck frame level. Therefore, the hoist may have to be moved slightly forward or backwards to avoid frame crossmembers. The distance between the rear hinge assembly center and the center of the lower pivot is referred to as the "M Dimension". The table on Mounting Dimensions drawing 662867 provide the dump angles associated with the "M Dimensions".

Note: Moving the hoist along the truck frame will affect the hoist's performance. A forward movement (towards the cab) decreases dump angle and increases capacity. A backwards movement increases dump angle and decreases capacity. Reference Capacity Chart drawings 662851.



VENCO VENTURO INDUSTRIES LLC
CINCINNATI, OHIO

TITLE	MOUNTING INSTRUCTNS
VC6628	

DATE	07-12-22A
SUPERSEDES	12-17-15

SECTION	H200
	662871

HOIST MOUNTING INST. - VC6628

- E. After the hoist is positioned, place the mounting angles (Figure 3) under the lower pivot angles and against the truck frame. Clamp securely in place. Drill through the frame and install the mounting angle with two [2] 1/2-13 x 1-1/2" Grade 8 hex head cap screws, lock washers, hex nuts, and four [4] flat washers (both sides).



C A U T I O N

- The hoist lower pivot assembly must sit flush on the truck frame. If rivet head interference is encountered, use a filler block or countersink clearance holes in the bottom of the pivot assembly. DO NOT weld hoist mounting angle to truck frames - this may void the truck warranty.

- F. Weld each end of the lower pivot angle to its mounting angle as shown in Figure 3. Note the welding symbols. Do not weld to the truck frame.

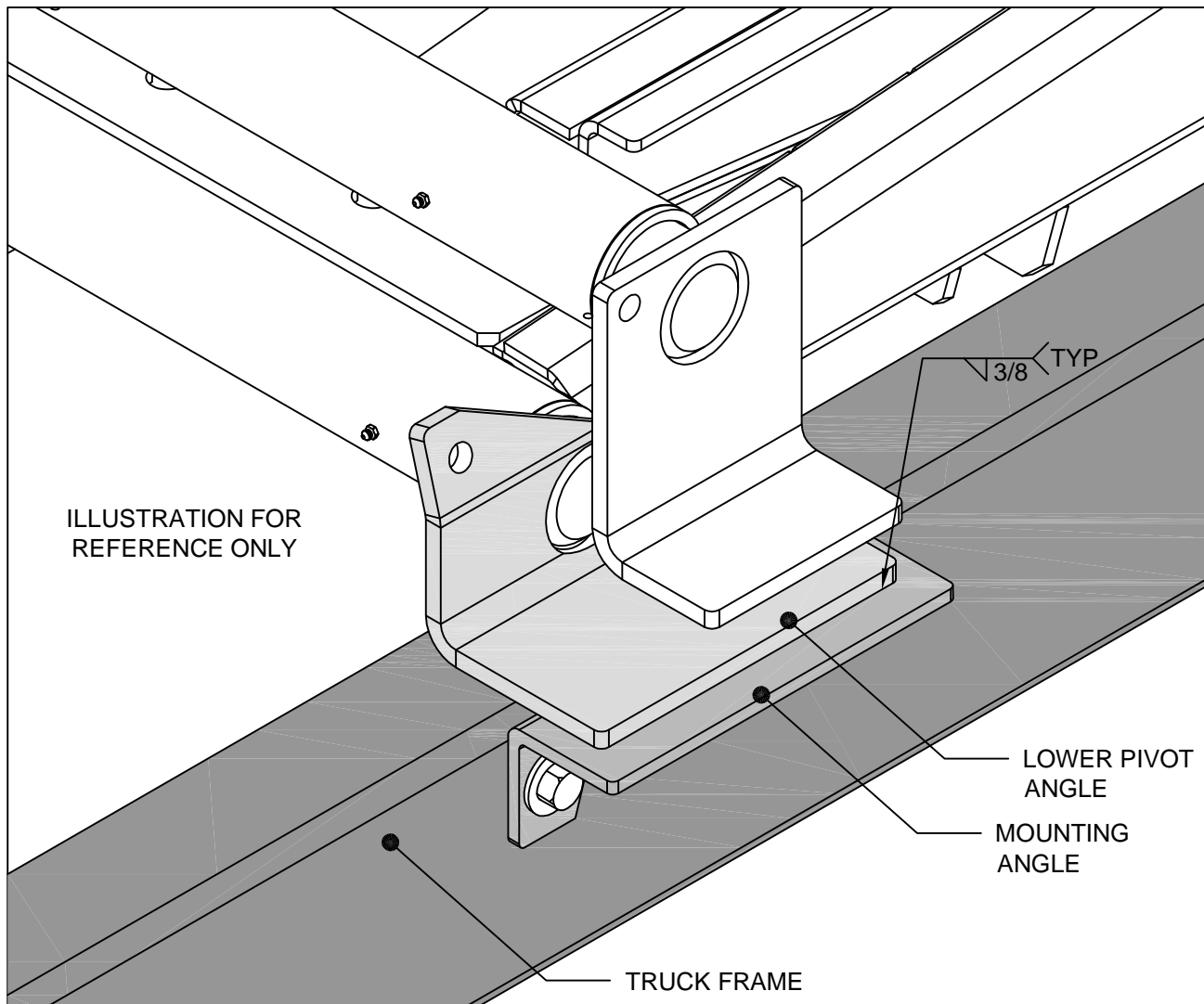

Figure 3. Mounting angle assembly.



VENCO VENTURO INDUSTRIES LLC
CINCINNATI, OHIO

TITLE
MOUNTING INSTRCTNS
VC6628

DATE
12-17-15
SUPERSEDES
-

SECTION
H200
662872

HOIST MOUNTING INSTRUCTIONS (CONT.)

G. Install hydraulic hoses per the following instructions:

- ▲ 1. 7' (or 7'-10") hose(s) installation - Connect one end of the hose to the front pump port (low pressure). Connect the other end of the hose to the rod end of the hoist cylinder (Reference DWGs 416763 and 552004).
- ▲ 2. 5' hose(s) installation - Connect one end of the hose to the rear pump port (high pressure). Connect the other end of the hose to the base end of the hoist cylinder (Reference DWGs 416763 and 552004).

H. Position and secure the filler strips (liner or sleeper) to the truck frame.

The VC6628 requires a minimum of 10-1/2" clearance above the truck frame.

NOTE: If the hoist needs to be mounted higher due to interference between the hoist knuckle and the truck frame, additional clearance above the truck frame will be required.

EXAMPLE:

Assuming that an 10-1/2" clearance is required and 6" long beams are on the truck body, a liner of at least 4 1/2" net will be required to obtain the minimum clearance required to mount the hoist.

$$6" + 4 \frac{1}{2}" = 10\text{-}1\frac{1}{2}" \text{ minimum}$$

I. Position the body longitudinals (long beams) onto the truck frame / sub-frame.

NOTE: At least 2" clearance between the cab and closest point on the truck body is required.

J.

a. STANDARD HINGE (662806)

With the body aligned with the truck frame, push the hinge rockers outward as far as possible. Ensure that the longitudinal rails are sitting flat on the rockers, weld the body longitudinals to rockers (DWG 662871 Figure 2). See installation DWG 628861 for more information regarding the mounting of the rear hinge rockers to the body.

K. **Refer to DWG 520093 on the following page.** Make sure that the dump body longitudinals are resting flush on the top of the lifting angles. Weld the top of both lifting angles (the vertical 'leg') to the top flanges of the body longitudinals - a reinforcement plate may be required to fill the space between the lifting angles and body longitudinals. Weld all around the lifting angles, body longitudinals, and reinforcement plates (if applicable). **Be sure that your installation follows the method shown on the following page (DWG 520093).**



CAUTION



- Step "K" (above) is a critical installation procedure that must be carefully followed to ensure a successful hoist installation. Deviation from the suggested installation method may result in damage to the hoist.



VENCO VENTURO INDUSTRIES LLC
CINCINNATI, OHIO

TITLE	MOUNTING INSTRCTNS
VC6628	

DATE	08-01-17A
SUPERSEDES	12-17-15

SECTION	H200
	662873

IMPORTANT!

WHEN INSTALLING THE UPPER LIFTING ANGLES, THE GOAL IS TO COMPLETELY "BOX IN" THE LIFTING ANGLE, BODY LONG SILL SPACER, AND REINFORCEMENT PLATE - 100% WELD.

**SITUATION A:
LIFTING ANGLE FULLY
ENVELOPS BODY LONG SILL.**

▲ COLLAR SHOULD BE PROPERLY LOCATED AND STITCH WELDED TO PIVOT ROD TO LIMIT SIDE-TO-SIDE MOVEMENT OF SCISSORS (416-520 ONLY).

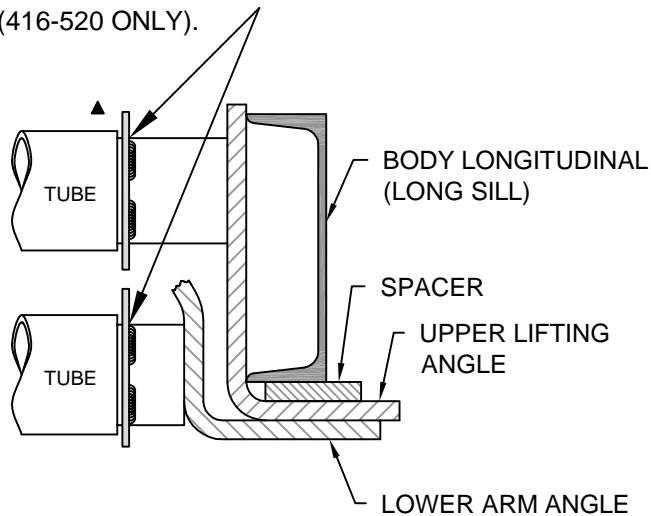

**SITUATION B:
LIFTING ANGLE DOES NOT
ENVELOP BODY LONG SILL AND
A REINFORCEMENT PLATE
IS REQUIRED.**

▲ COLLAR SHOULD BE PROPERLY LOCATED AND STITCH WELDED TO PIVOT ROD TO LIMIT SIDE-TO-SIDE MOVEMENT OF SCISSORS (416-520 ONLY).

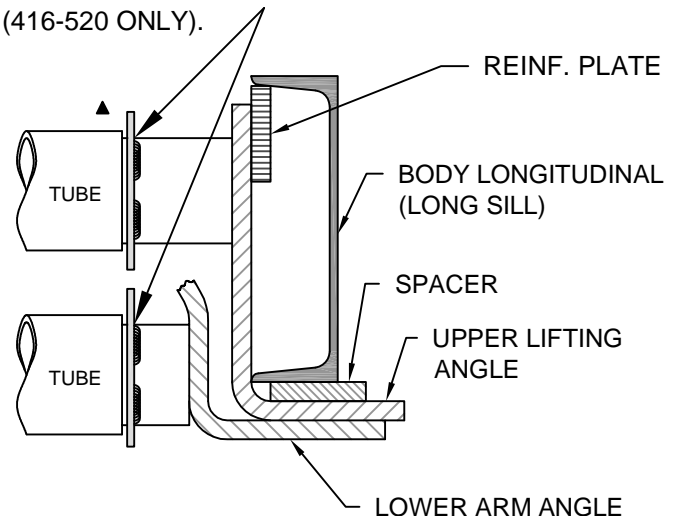

NOTE: THE SPACER AND REINFORCEMENT PLATE SHOULD BE THE SAME LENGTH AS THE LIFTING ARM. SEE 'L' DIMENSION BELOW.

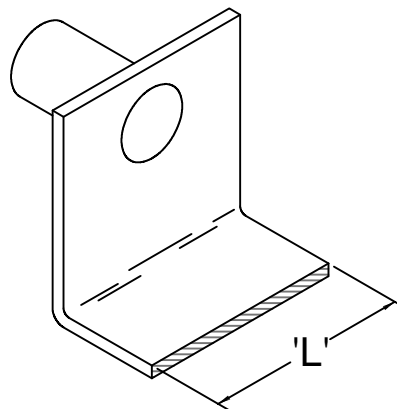

VENCO VENTURO INDUSTRIES LLC
CINCINNATI, OHIO

TITLE
INSTLL. INSTRUCTIONS

DATE
08-20-14E

SECTION
H200

VC416-6628, TRLR313-6628

SUPERSEDES
01-14-13D

520093

HINGE MOUNTING INST. VC628 - 6628

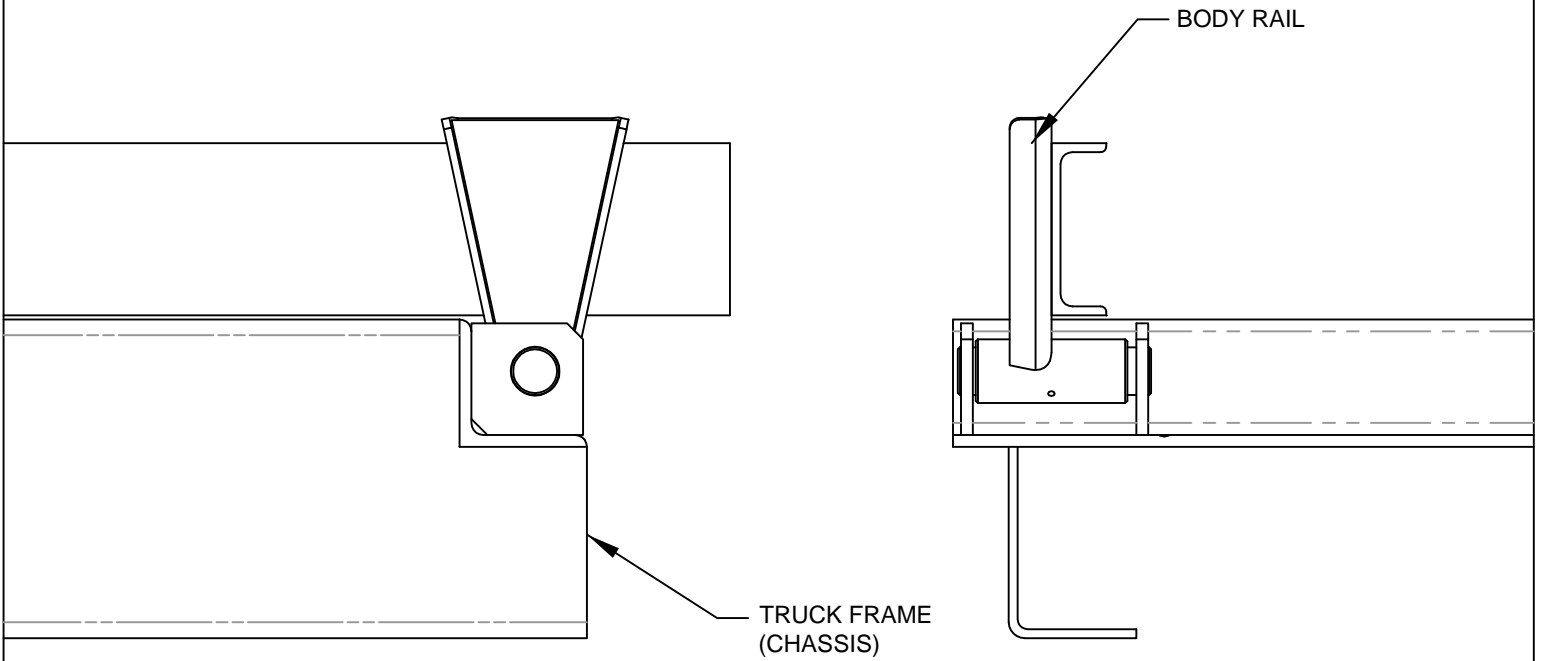

662057-1 HINGE
VC628-6620

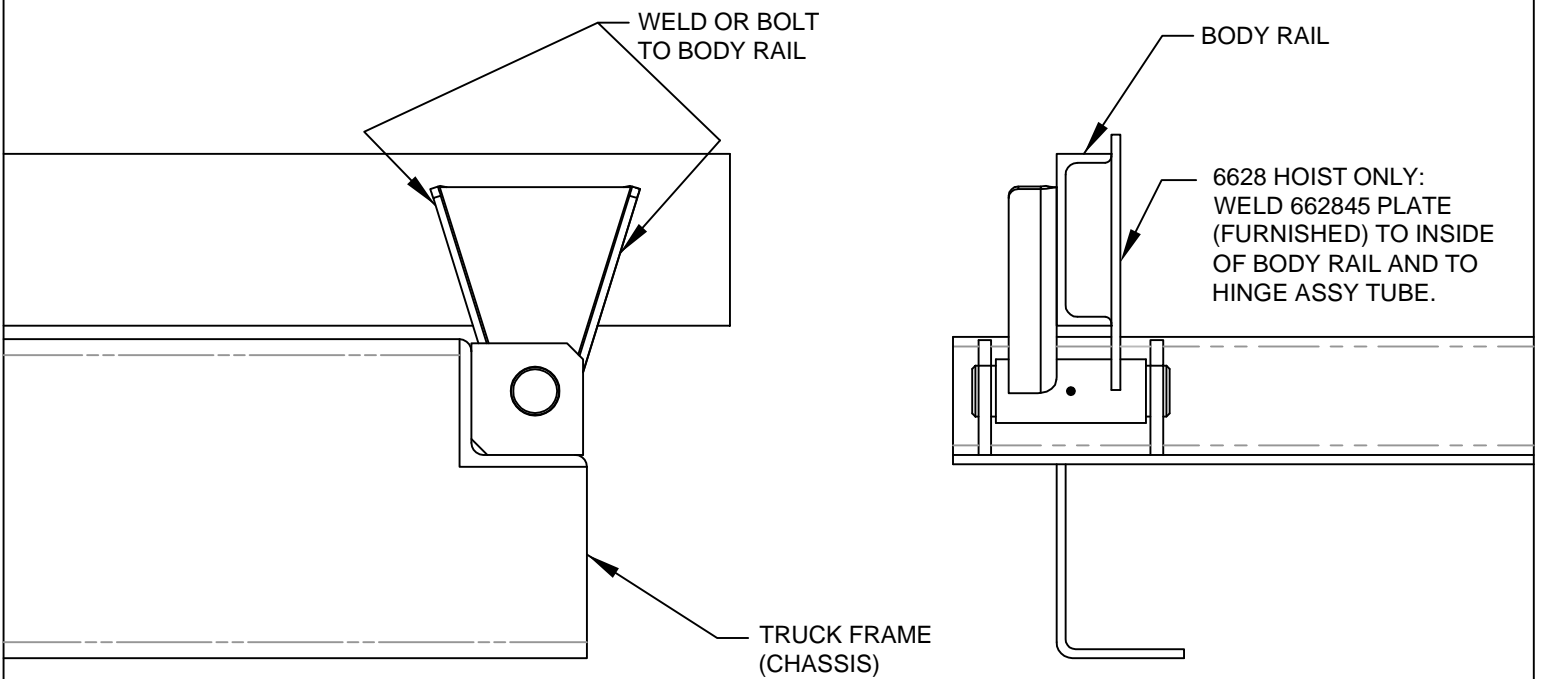

662806 HINGE
VC6628 ONLY



VENCO VENTURO INDUSTRIES LLC
CINCINNATI, OHIO

TITLE
HINGE TO BED MNTG

VC628-6628

DATE
12-08-15

SUPERSEDES
-

SECTION
H200

628861

ATTACHING 620129 CABLE TO 620131 / 132 HANDLE

- Step 1. Remove lowest screw & nut.
- Step 2. Depress red button on top of handle. Push handle forward and hold.
- Step 3. While holding handle, thread "barrel nut" into threaded hole in bottom and tighten.
- Step 4. Release handle. Handle should return to center position.
- Step 5. Replace screw & nut, making sure that radius on cable end is aligned with screw hole. After tightening screw, move handle forward and backward to make sure cable end is secure in console.

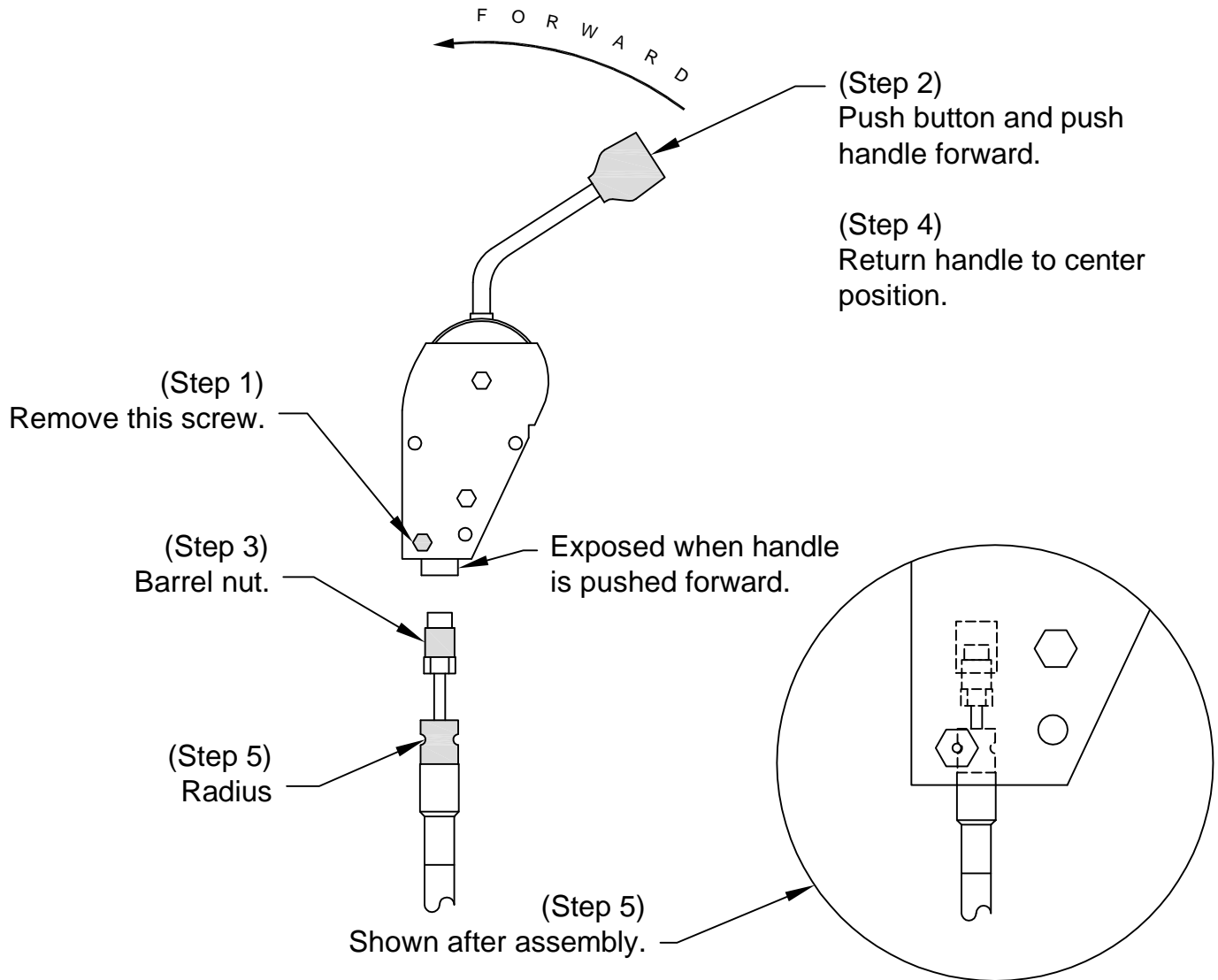

VENCO VENTURO INDUSTRIES LLC
CINCINNATI, OHIO

TITLE
CABLE / HANDLE ASSY
PTO PUMP CABLE

DATE
11-05-15B
SUPERSEDES
03-17-14A

SECTION
-
620246

PTO PUMP CABLE INSTALLATION

1. Thread 0.750-16 UNF jam nut entire length of threaded hub and onto cable.
2. Place flange on sleeve and turn flange / sleeve assembly entire length of threaded hub and onto cable.
3. Threade 0.250-28 UNF jam nut onto threaded rod until it bottoms.
4. Thread terminal eye onto threaded rod and bottom against jam nut, turn to align with spool slot and secure jam nut against terminal eye.
5. Slide terminal eye into slot in spool and align holes. Insert connecting pin and secure with cotter pin (if applicable).
6. With cable attached to valve and input device, thread the flange / sleeve assembly onto the threaded hub until it is flush with the valve face. When turning the flange / sleeve assembly, make sure the input device remains in the neutral position.
7. Tighten the 0.750-16 UNF jam nut against the sleeve to lock in position.
8. Bring flange into position and bolt assembly to valve housing using two [2] socket head cap screws and two [2] split lock washers under head and two [2] flat washers under lockwashers. Tighten screws sufficiently to flatten lock washers or secure flange (see CAUTION).

CAUTION

- Excessive torque or over-tightening will distort flange.

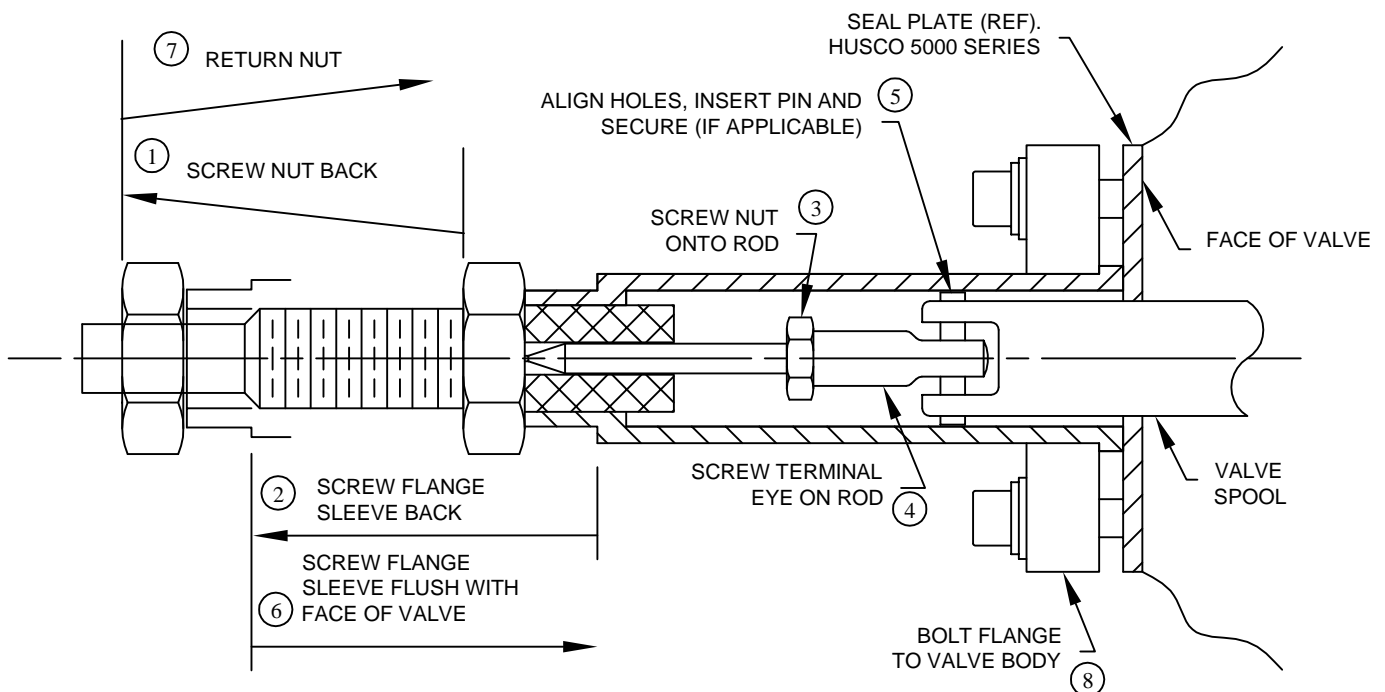

VENCO VENTURO INDUSTRIES LLC
CINCINNATI, OHIO

TITLE	PTO PUMP CABLE INSTL
TITLE	VC416-6628

DATE	11-05-15B
SUPERSEDES	03-17-14A

SECTION	-
SECTION	416755

DIRECTIONAL PUMP CONFIGURATION FOR VC416-620

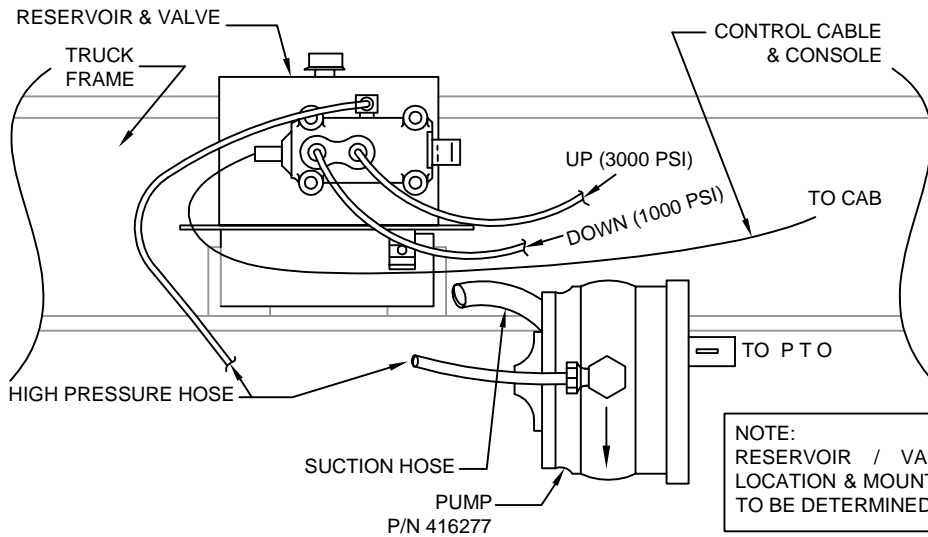

BI-DIRECTIONAL PUMP CONFIGURATION FOR VC628 & UP

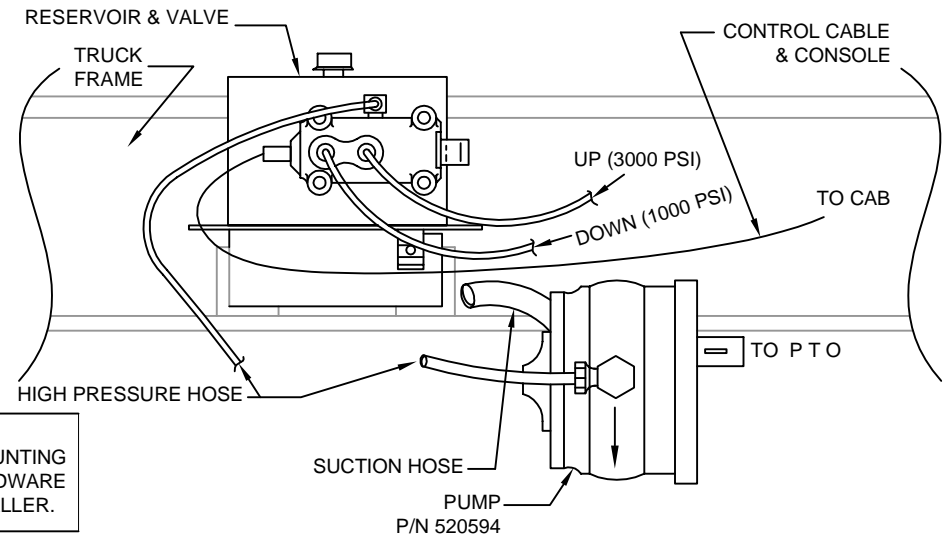

NOTE:
RESERVOIR / VALVE MOUNTING
LOCATION & MOUNTING HARDWARE
TO BE DETERMINED BY INSTALLER.

NOTE: ARROW ON PUMP HOUSING INDICATED ROTATION DIRECTION.
FAILURE TO MATCH PTO ROTATION WITH PUMP ROTATION **WILL**
RESULT IN PUMP FAILURE.

NOTE: FOR BI-ROTATIONAL PUMP MOUNTING AND HOSE CONNECTION
INFORMATION, SEE DWG 416812 (IF APPLICABLE).

Model	VC416	VC516	VC520	VC620	VC628	VC5520	VC6620	VC6628
Control Cable & Console				620125 - Curved	620124 - Straight			
Cylinder Up Hose	416044		416045			520574		
Cylinder Down Hose				416045		628041	(2) 416045	
High Pressure Hose (pump to valve)	416045 (7' LG, 3/8 HOSE)			620909 (10' LG, 3/8 HOSE) FOR VC620 NON-SF		620909 (10' LG, 3/8 HOSE)		
				416045 (7' LG, 3/8 HOSE) FOR VC620 SF				
Suction Hose (reservoir to pump)	416079 (7' LG, 1.00" I.D.)			620910 (10' LG, 1.00" I.D.) FOR VC620 NON-SF		520088F (10' LG, 1-1/4" I.D.)		
				416079 (7' LG, 1.00" I.D.) FOR VC620 SF				
Pump/Valve/Tank	620011 (9 QUART)			662077 (21 QUART)				
Pump (Only)	416277 (5gpm)			520594 (10gpm)				



VENCO VENTURO INDUSTRIES LLC
CINCINNATI, OHIO

TITLE
SPLIT PUMP

VC416-6628

DATE 03-16-22E	SECTION H200
SUPERSEDES 08-01-17D	416763

BI-ROTATIONAL PUMP INSTALLATION

CLOCKWISE ROTATION PTO REQUIRES
COUNTER-CLOCKWISE ROTATION PUMP

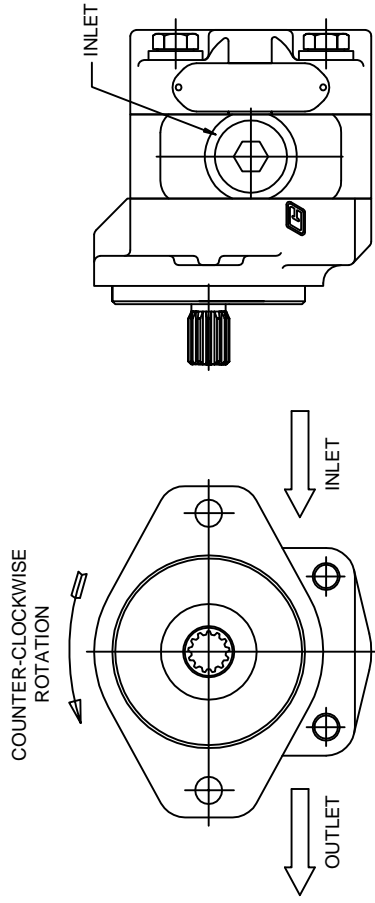

TO VERIFY THE INLET PORT ON A BI-ROTATIONAL PUMP,
DETERMINE WHICH WAY THE SHAFT OF THE PUMP IS GOING
TO TURN FROM THESE TWO SAMPLE DIAGRAMS AND PLUMB
ACCORDINGLY.

NOTE: DO NOT OPERATE THE PUMP WITHOUT OIL.

COUNTER-CLOCKWISE ROTATION PTO
REQUIRES CLOCKWISE ROTATION PUMP

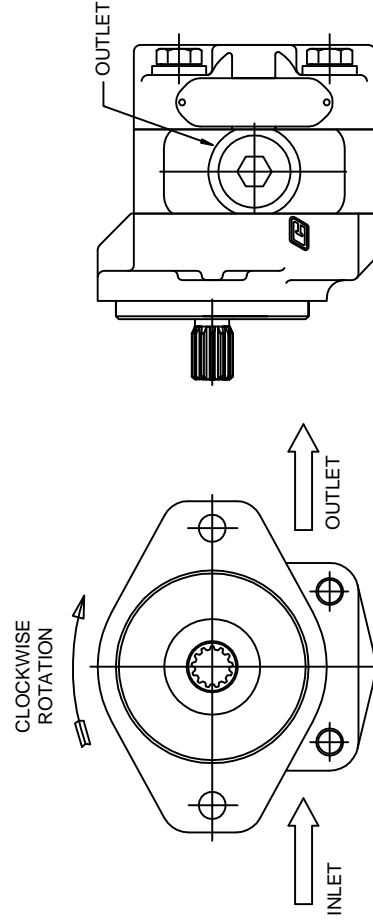

TITLE
BI-ROTATIONAL PUMP INSTALLATION

DATE
12-09-15A

SECTION
-

SUPERSEDES
06-02-05

416812

VC628-6628



VENCO VENTURO INDUSTRIES LLC
CINCINNATI, OHIO

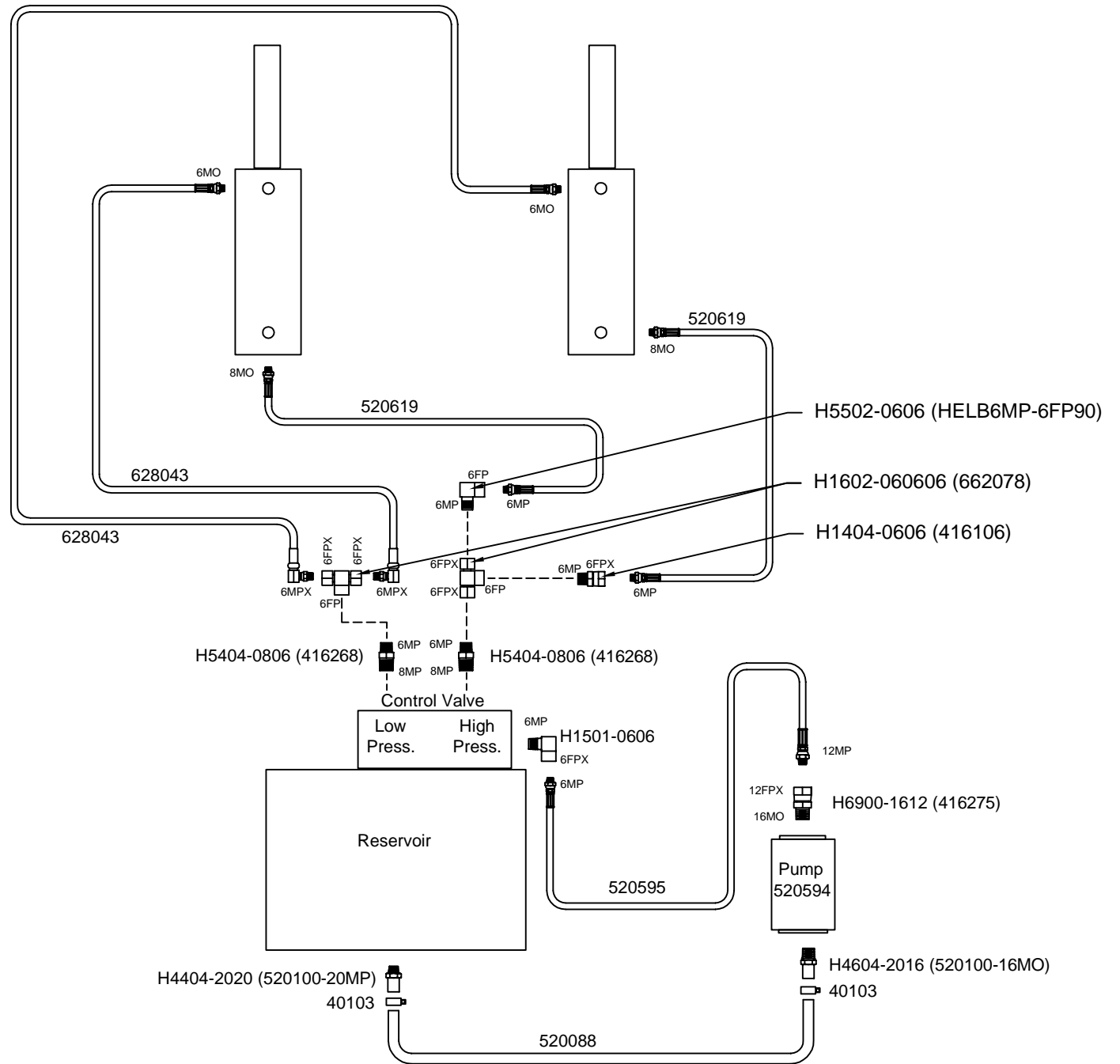

VENCO VENTURO INDUSTRIES LLC
CINCINNATI, OHIO

TITLE
SPDG HOSE CONNECTION DIAGRAM

VC6620/6628

DATE
09-09-16C

SUPERSEDES
07-20-16B

SECTION

-

552004

Williams[®] Machine & Tool Co.

MANUFACTURERS OF HYDRAULIC PISTON PUMPS



CAUTION



- The gear pump you have purchased is a single rotation Gear Pump. Installation of this Gear Pump into a system that does not match the rotation of the Gear Pump may result in personal injury and/or property damage.

The Gear Pump you have purchased is a single rotation Gear Pump. The direction of rotation can be found by using the Williams Machine and Tool Co.'s Model Number. Directly following the Model Number are the letters CCW or CW. These letters indicate the direction of rotation for the Gear Pump. CCW indicates a counter-clockwise rotation. CW indicates a clockwise rotation. Pump shaft rotation is determined by viewing pump from the shaft end.

Example: GP1538 CCW. The CCW indicates a counter-clockwise rotation.

To verify the direction of rotation of your Gear Pump, perform the following steps:

- 1.) Locate the Part Number on the Gear Pump. The Part Number, Serial Number, and date code are located on the rear of the Gear Pump.
- 2.) Part Numbers ending in an even number are clockwise rotation (CW). Part Numbers ending in an odd number are counter-clockwise rotation (CCW).

Example: 1830201. The last number is 1 (an odd number). This indicates a counter-clockwise rotation (CCW).

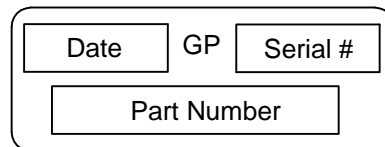

The following chart specifies torque requirements for the SAE O' ring plugs installed into the side or rear ports of the Gear Pump. Any combination of inlet and outlet ports may be used, ie., inlet large rear port. outlet small side port; inlet large side and outlet small rear ports; or both side ports or both rear ports. One inlet and one outlet part must be plugged for proper Gear Pump operation.

PORT SIZE (SAE)	TORQUE (FT. LBS)
3/4 - 16	15 - 20
7/8 - 14	20 - 25
1 - 1/16 - 12	30 - 35
1 - 5/16 - 12	45 - 50
1 - 5/8 - 12	65 - 70



VENCO VENTURO INDUSTRIES LLC
CINCINNATI, OHIO

TITLE

WILLIAMS PTO WARNING

DATE

11-05-15D

SECTION

H200

SUPERSEDES

03-17-14C

416287

Included with your Venco hoist are various danger, warning, and caution decals. These decals must be placed in prominent locations so they are easily seen and readily identifiable. This illustration provides the recommended decal locations.

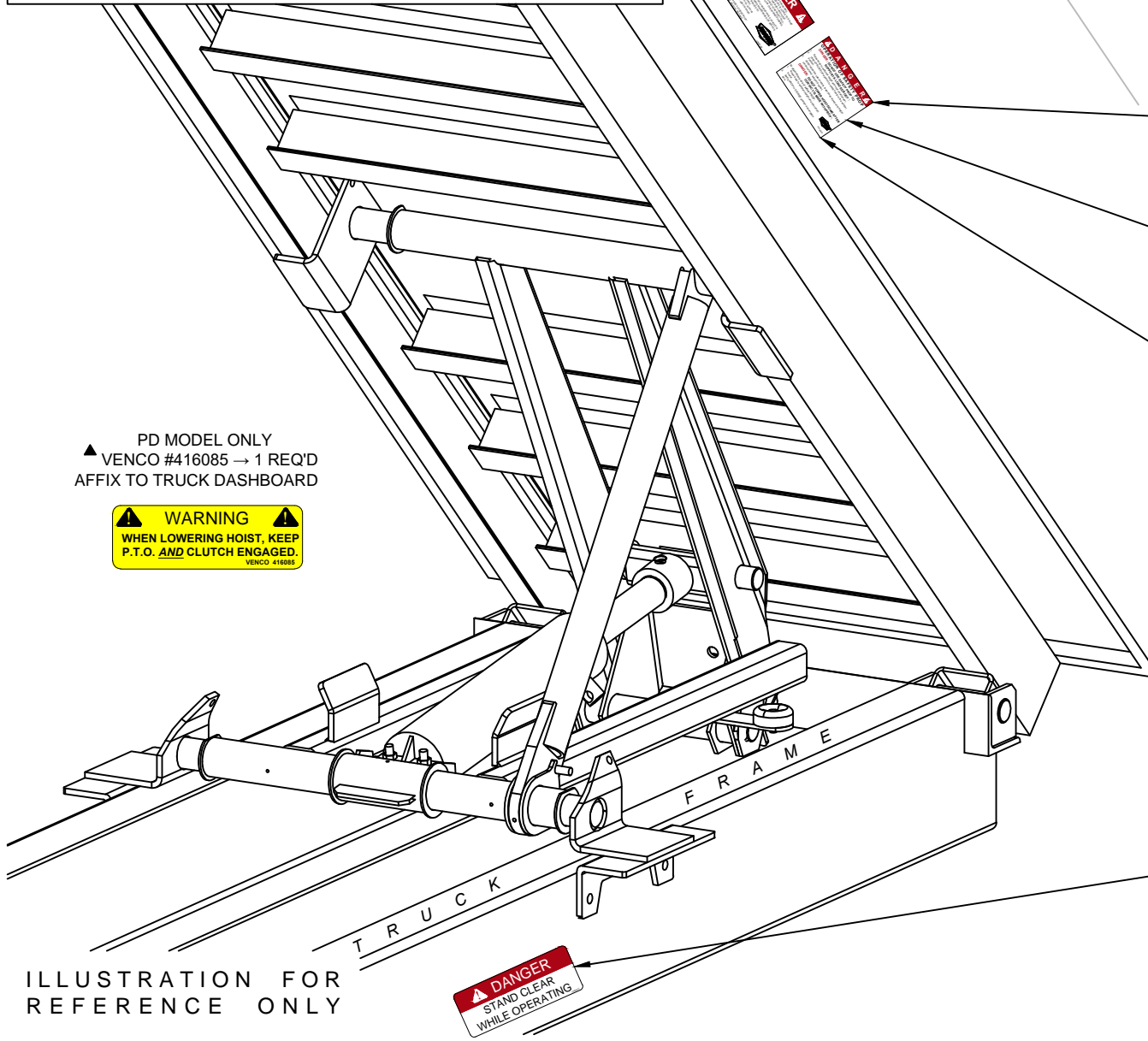

PD MODEL ONLY
 ▲ Venco #416085 → 1 REQ'D
 AFFIX TO TRUCK DASHBOARD



ILLUSTRATION FOR
 REFERENCE ONLY



Venco #416052
 2 REQ'D (1 EACH SIDE)



Venco #416084
 1 REQ'D FOR EACH SIDE
 SAFETY PROP
 (SWING-DOWN)

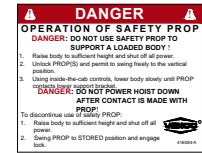

Venco #416626
 1 REQ'D FOR EACH SIDE
 SAFETY PROP
 (INDEXING)

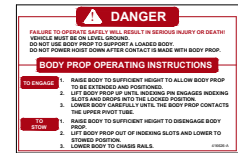

Venco #416624
 1 REQ'D FOR EACH SIDE
 SAFETY PROP
 (LINKAGE)

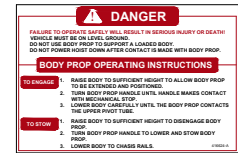

Venco #15254
 2 REQ'D (1 EACH SIDE)



VENCO VENTURO INDUSTRIES LLC
 CINCINNATI, OHIO

TITLE
 DECAL LOCATIONS

VC416-6628, TRLR416-6628

DATE
 01-29-24G

SUPERSEDES
 10-27-15F

SECTION
 H200

416128

SECTION 250

OPERATION



VENCO VENTURO INDUSTRIES LLC
CINCINNATI, OHIO

HOIST MAINTENANCE AND OPERATION INSTRUCTIONS

- A. Hoist unit lubrication
1. Lubricate all grease fittings on the hoist unit.
 2. Lubricate the rear hinge assembly.
 3. The hoist system should be serviced at the same time the truck is serviced, and sooner if the hoist unit is performing heavy duty service.
 4. Pump Reservoir → Shall be filled with the recommended oil per the manufacturer's instructions. Periodically check the hydraulic fluid and change when the truck engine oil is changed.
- B. PTO Pump Operation
- With the hoist and body completely installed, cycle the hoist several times to purge the hydraulic system of air. Operate the hoist system per the instructions in this manual and per the PTO manufacturer's instructions.



C A U T I O N



- Do not operate the pump at more than 1000 RPM. Severe hoist system damage could result. The PTO speed to engine speed is governed by the gear ratio of the PTO drive installed in the truck transmission.
- For long service and safety from VC hoists, it is important that the following procedure be followed each time the hoist is operated:

1. Engage the PTO from the truck cab and adjust the engine speed to obtain the correct PTO and lift speed desired.
2. Pull the pump stick out. This will cause the hoist to raise.
3. When the pump has reached its maximum capacity, the pump will bypass through the relief valve. To prevent the pump from bypassing, push the pump knob to the center / middle position. Whenever the pump knob is centered, the hoist will stop moving and hold its position.



C A U T I O N



- Do not allow the pump to bypass for long periods of time, as this will put stress on the hydraulic and electrical systems of the hoist.

4. To lower the hoist, push the pump stick in.
NOTE: The Venco hoist powered by PTO drive pumps must be 'powered down'. Failure to 'power down' will cause the reservoir to overflow.
5. To lock the hoist against the truck frame when it is in the down position, push the pump knob in. When the pump bypasses, place the knob in the center 'hold' position.
6. Disengage PTO from transmission per the manufacturer's instructions.



C A U T I O N



- Do not drive the truck without first disengaging the PTO. Failure to disengage the PTO may result in severe damage to the pump and pump drive unit.



VENCO VENTURO INDUSTRIES LLC
CINCINNATI, OHIO

TITLE

MAINT. & OPER. INSTRC.

DATE

11-05-15D

SECTION

H250 ▲

VC 520-6628

SUPERSEDES

08-12-15C

520079

BODY PROP OPERATION GUIDE - GENERAL INFORMATION

D. Body prop(s): Federal Regulation 1926.601, Paragraph 10, requires the use of a body prop. Accordingly, all Venco hoist units will have included as a standard item a body prop (safety strut). See Paragraphs D.1. & D.2. below.

1. The body prop is designed for use only when the truck body is **empty**. The purpose of the body prop is to provide a safety strut for use when maintenance or inspections are performed on an **unloaded** truck body in the raised position.
2. One [1] body prop shall be furnished for truck bodies up to and including 15 feet. For bodies longer than 15 feet in length, two [2] body props should be used.
3. Venco hoists are equipped with one of three types of body props: **Indexing**, **Swing-down** or **Linkage**. The chart below shows the hoist model number and the corresponding body prop types available.



HOIST BODY PROP CONFIGURATION CHART				
HOIST MODEL	STD. BODY PROP TYPE	OPTIONAL LINKAGE BODY PROP	DUAL BODY PROP	OPERATIONAL DECAL PART NUMBER
VC416/516	INDEXING	OPTIONAL	NOT AVAILABLE	INDEX= 416626, LINKAGE= 416624
VC520	INDEXING	OPTIONAL	NOT AVAILABLE	INDEX= 416626, LINKAGE= 416624
VC620	SWING-DOWN	OPTIONAL	NOT AVAILABLE	SWING-DOWN=416084, LINKAGE=416624
VC628	SWING-DOWN	NOT AVAILABLE	OPTIONAL	SWING-DOWN=416084
VC6620	SWING-DOWN	NOT AVAILABLE	OPTIONAL	SWING-DOWN=416084
VC6628	SWING-DOWN	NOT AVAILABLE	STANDARD	SWING-DOWN=416084

NOTE: For an illustration and operating instructions for each body prop type, see page 416645 in this manual.

4. Special Precautions for Swing-down Body Props -

- Make sure the truck is parked on a **flat level surface**.
- Use a suitable tool to pull out the Spring-loaded release pin (stowage device) to release the body prop from the hoist frame. This will release the body prop allowing it to swing downward to a vertical position.
- Make sure that the body prop is aligned with the body prop foot rest (the body prop will be in a vertical position), then allow the truck body to move downward until the body prop is seated in the foot rest.
NOTE: DO NOT POWER DOWN AFTER MAKING CONTACT WITH BODY PROP FOOT REST
- To disengage the body prop, raise the truck body until the body prop swings freely away from the foot pad. Using a suitable tool, place the tool in a leverage position on the body prop and propel sharply to the left and upward (or to the right and upward) so that the locking pin can be compressed and seated in the locking pin hole. Make certain the body prop is latched securely before the hoist is operated.

WARNING

- Do not place arms, hands, or any part of the body between the truck longitudinals (long beams) or moving parts to pull the body prop release / locking pin.

WARNING

- Do not use the body prop(s) to support a loaded truck body.
- Body prop(s) should be free swinging to a vertical position after the locking pin is released

WARNING

- Read operation of safety strut and caution labels **before** operating the hoist.

WARNING

- Use care when reseating the body prop(s) in the locked position.



VENCO VENTURO INDUSTRIES LLC
CINCINNATI, OHIO

TITLE
BODY PROP OP. GUIDE

DATE
11-05-15A

SECTION
H250 ▲

VC416 - VC6628 HOISTS

SUPERSEDES
5-28-14

416644

BODY PROP OPERATION GUIDE - ILLUSTRATIONS & INSTRUCTIONS

VC628 - VC6628 (STANDARD) SWING-DOWN BODY PROP

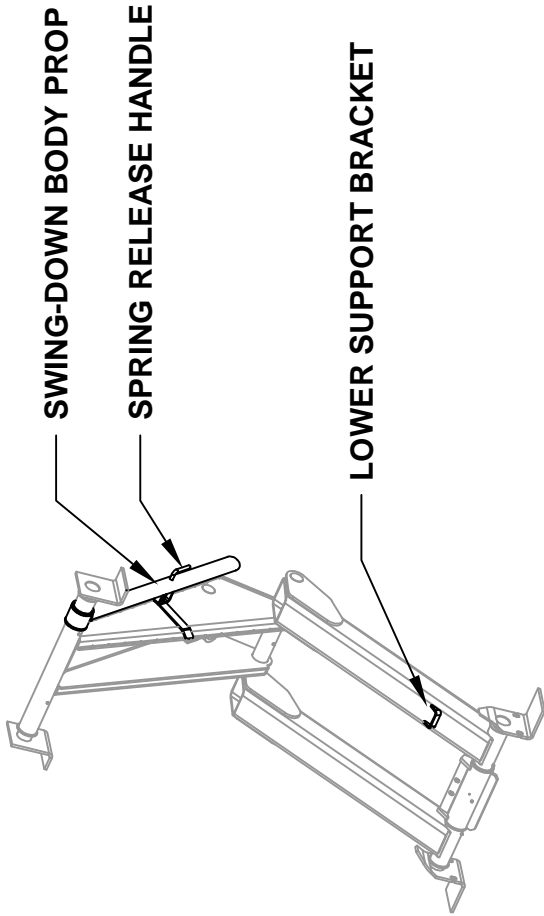

NOTE: DUAL BODY PROPS ARE STANDARD ON HOIST MODEL VC6628. REFER TO THE HOIST BODY PROP CONFIGURATION CHART ON DRAWING 416644 TO DETERMINE THE AVAILABILITY OF DUAL BODY PROPS FOR OTHER HOIST MODELS.

⚠ D A N G E R ⚠

OPERATION OF SAFETY PROP
DANGER: DO NOT USE SAFETY PROP TO SUPPORT A LOADED BODY!

1. Raise body to sufficient height and shut off all power.
2. Unlock PROP(S) and permit to swing freely to the vertical position.
3. Using inside-the-cab controls, lower body slowly until PROP contacts lower support bracket.

DANGER: DO NOT POWER HOIST DOWN AFTER CONTACT IS MADE WITH PROP!

To discontinue use of safety PROP:

1. Raise body to sufficient height and shut off all power.
2. Swing PROP to STORED position and engage lock.



416084-A

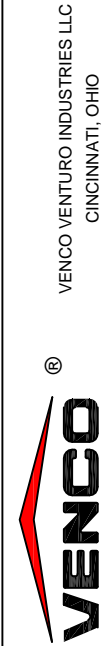

TITLE
BODY PROP OPERATIONS
 VC628-6628

DATE
12-09-15
 SUPERSEDES
 -

SECTION
H250

628645

SECTION 300

MAINTENANCE

&

SERVICE



VENCO VENTURO INDUSTRIES LLC
CINCINNATI, OHIO

HOIST GREASE POINTS

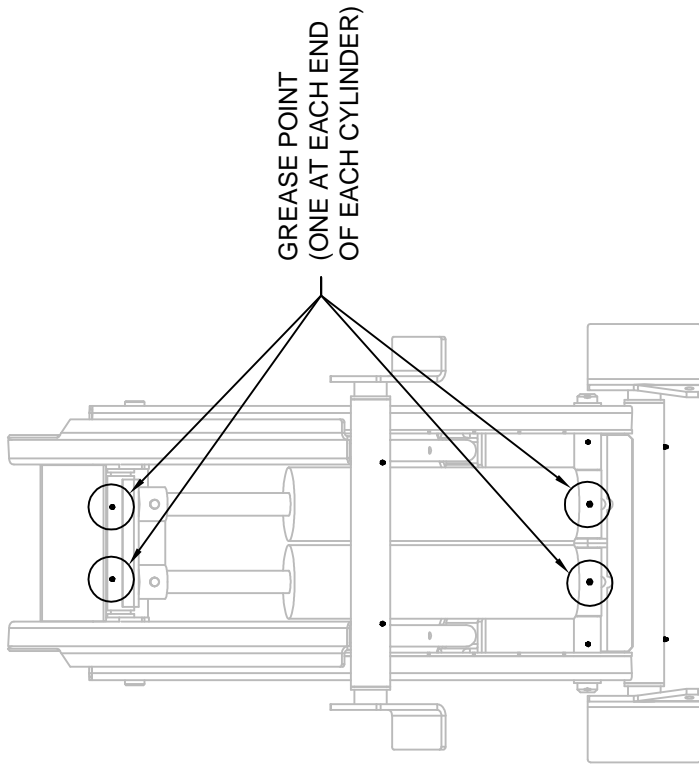

TOP VIEW

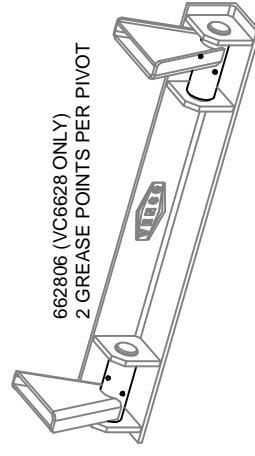
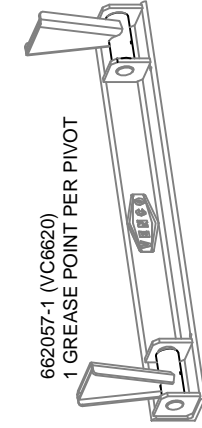
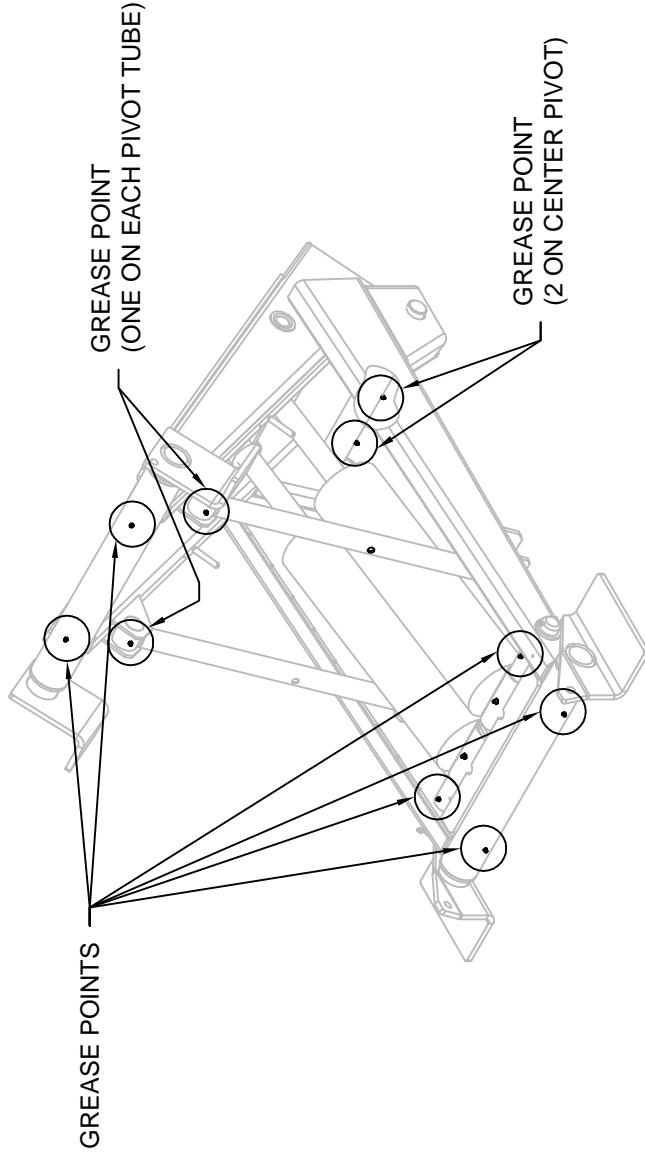

TO ENSURE THE RELIABLE PERFORMANCE OF YOUR VENCO HOIST, IT IS NECESSARY THAT YOU GREASE THE HOIST AT THE TIME OF TRUCK SERVICE WITH CHASSIS GREASE. THE GREASE POINTS FOR THE HOIST SCISSORS AND REAR HINGES ARE SHOWN ABOVE. ADDITIONAL FITTINGS FOR TWIN CYLINDER HOISTS AND ADDITIONAL BODY PROPS ARE ALSO NOTED.



VENCO VENTURO INDUSTRIES LLC
CINCINNATI, OHIO

TITLE
GREASE POINTS FOR HOISTS

VC6620/6628

DATE
12-14-15

SUPERSEDES
-

SECTION

-

662124

SECTION 400

REPLACEMENT PARTS



VENCO VENTURO INDUSTRIES LLC
CINCINNATI, OHIO

PART NO.: 416052
 DECAL: DANGER STAY CLEAR
 FUNCTION: To provide operator with a summary of key hoist operating procedures.
 QUANTITY: 2
 PLACEMENT: One on each side of body.

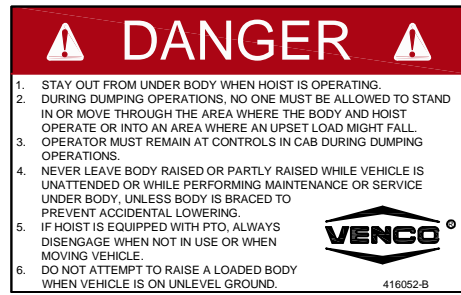

▲
 PART NO.: 416084 (VC620-VC6628 MODELS ONLY)
 DECAL: SAFETY PROP OPERATION
 FUNCTION: To inform the operator of proper operation of safety prop.
 QUANTITY: 1 For each safety prop.
 PLACEMENT: On side of body closest to safety prop(s).

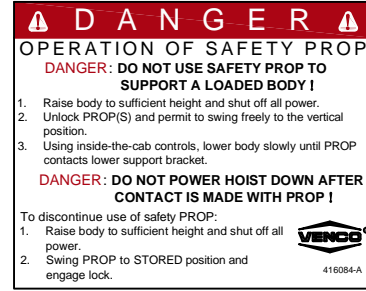

▲
 PART NO.: 416626 (VC416,516 & 520 MODELS ONLY)
 DECAL: SAFETY PROP OPERATION, 'INDEXING' ONLY
 FUNCTION: To inform the operator of proper operation of safety prop.
 QUANTITY: 1 For each safety prop.
 PLACEMENT: On side of body closest to safety prop(s).

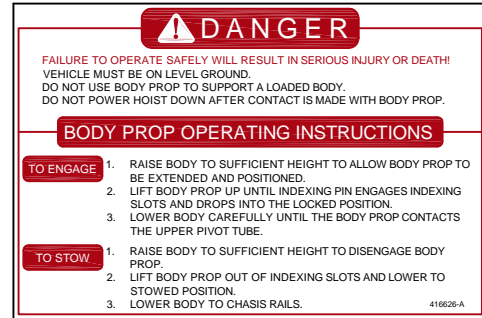

PART NO.: 15254
 DECAL: CAUTION STAND CLEAR
 FUNCTION: To inform the operator to stay clear of body / hoist.
 QUANTITY: 2
 PLACEMENT: One on each side of truck frame.



PART NO.: 416085
 DECAL: WARNING WHEN LOWERING
 FUNCTION: To inform the operator to keep P.T.O. and clutch engaged when lowering the hoist.
 QUANTITY: 1
 PLACEMENT: Affixed to truck dashboard.



	Venco VENTURO INDUSTRIES LLC CINCINNATI, OHIO	TITLE	DATE	SECTION
		DECAL LIST	11-05-15E	-
		VC/TRLR 416-6628	SUPERSEDES 03-26-14D	628820

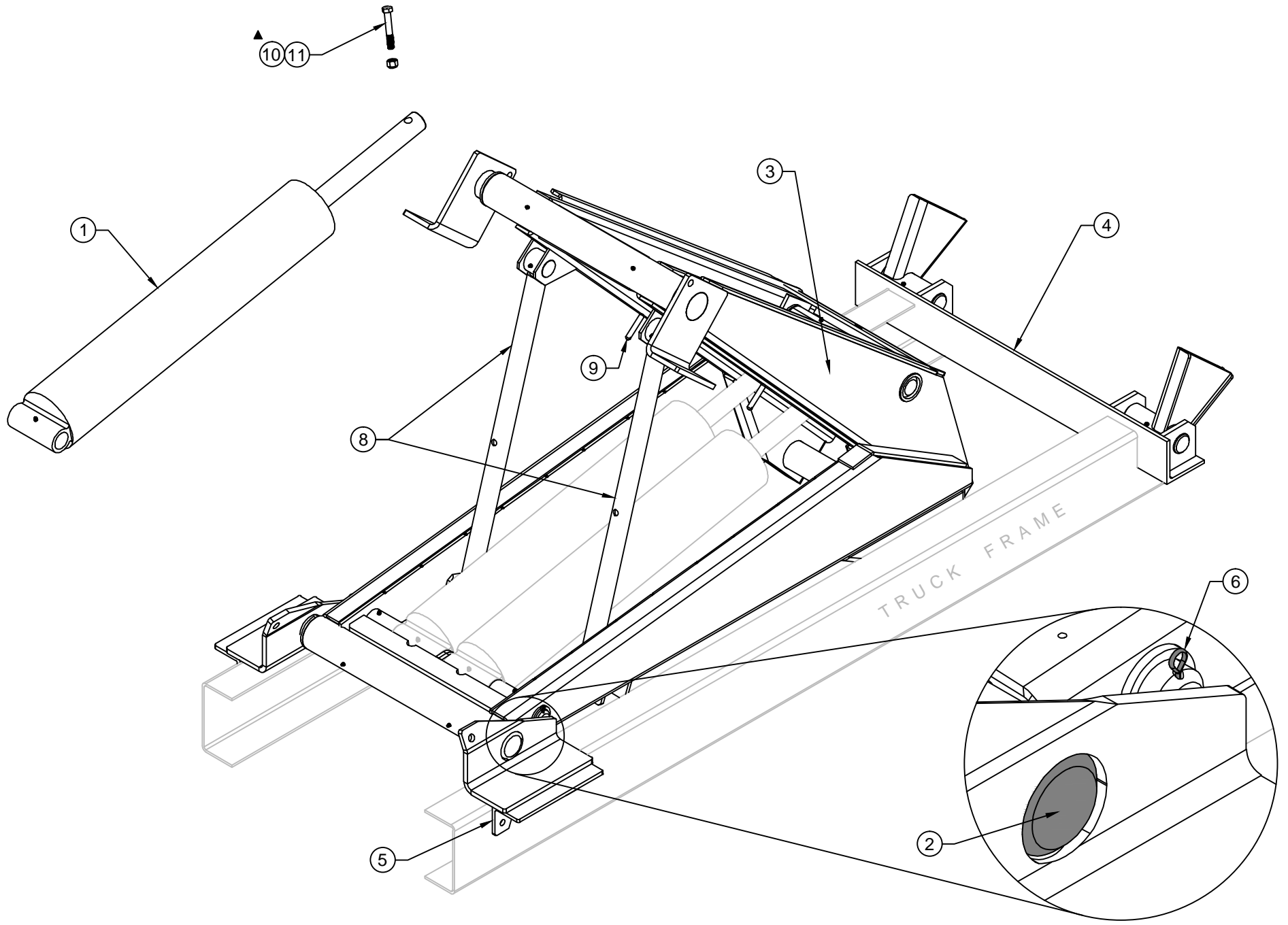

VENCO VENTURO INDUSTRIES LLC
CINCINNATI, OHIO

TITLE
REPLACEMENT PARTS DRAWING

VC6628

DATE
11-15-23E

SUPERSEDES
12-17-15D

SECTION
H400

662853

662853 REPLACEMENT PARTS LIST

ITEM	PART NUMBER	QTY.	DESCRIPTION
1	628900	2	CYLINDER; 6" BORE X 20" STROKE
2	662808	1	LOWER CYLINDER PIVOT SHAFT
3	662809	1	SCISSORS ASSEMBLY
4	662806	1	REAR HINGE ASSEMBLY
5	520920	2	MOUNTING ANGLE
6	416010	2	COTTER PIN; 1/4" X 3"
7	-	-	-
8	662836	2	BODY PROP (STANDARD)
9	662860	2	PIN; BODY PROP KEEPER
▲ 10	IHHCS06311400-8	1	HHCS; 5/8-11 X 4 GR.8
▲ 11	ILNUT-06311-8	1	LOCK NUT; 5/8-11, GR. 8, ZNC/YLW, NYL-INSERT
12	-	-	-
13	-	-	-
14	-	-	-
15	-	-	-
16	-	-	-
17	-	-	-
18	-	-	-
19	-	-	-
20	-	-	-
21	-	-	-
22	-	-	-
23	-	-	-
24	-	-	-
25	-	-	-
26	-	-	-
27	-	-	-
28	-	-	-
29	-	-	-
30	-	-	-
31	-	-	-
32	-	-	-
33	-	-	-
34	-	-	-
35	-	-	-

REPLACEMENT PARTS DWG REF 662853



VENCO VENTURO INDUSTRIES LLC
CINCINNATI, OHIO

TITLE
RPLCMNT PARTS LIST

DATE
11-15-23G

SECTION
H400

VC6628

SUPERSEDES
12-17-15F

662854

CABLE & CONSOLE KITS; 620125 (CURVED) & 620124 (STRAIGHT)

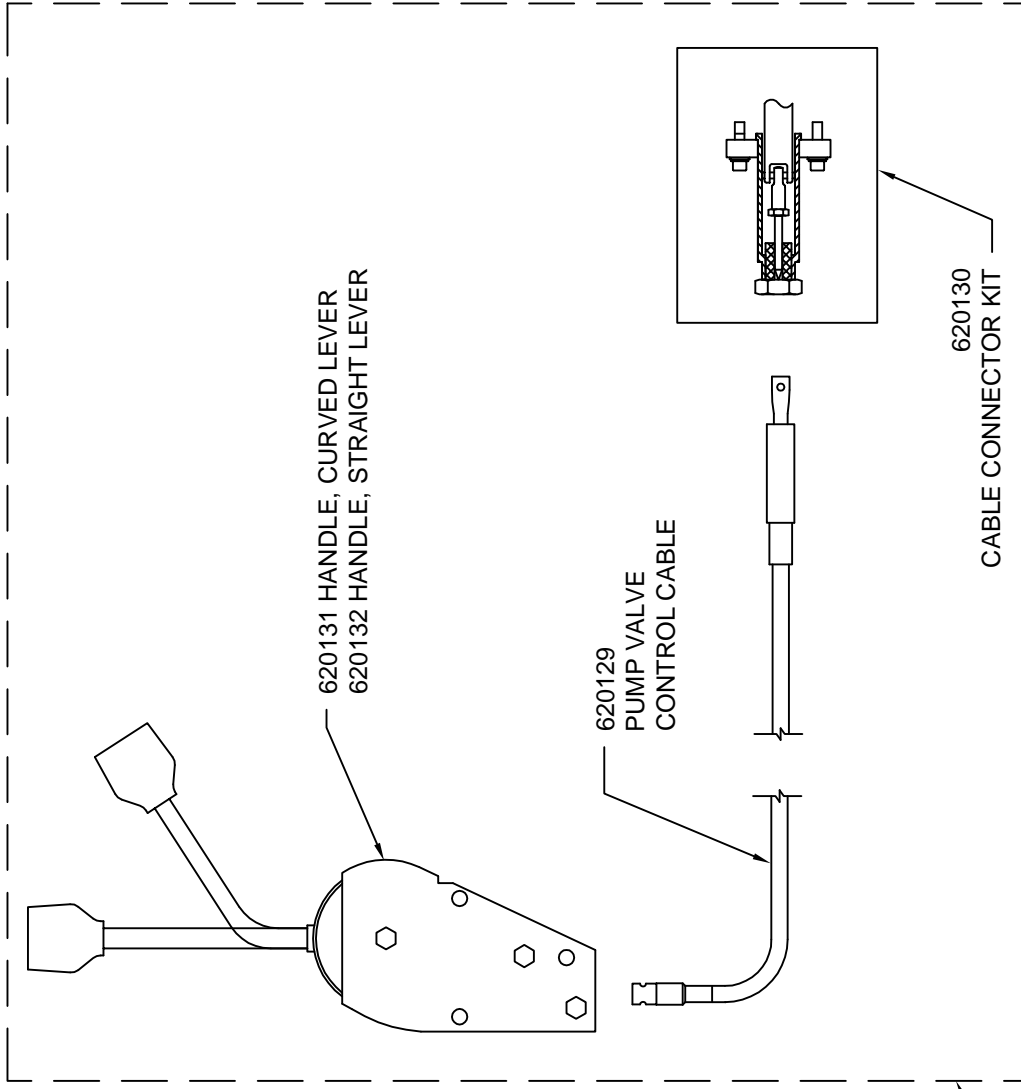
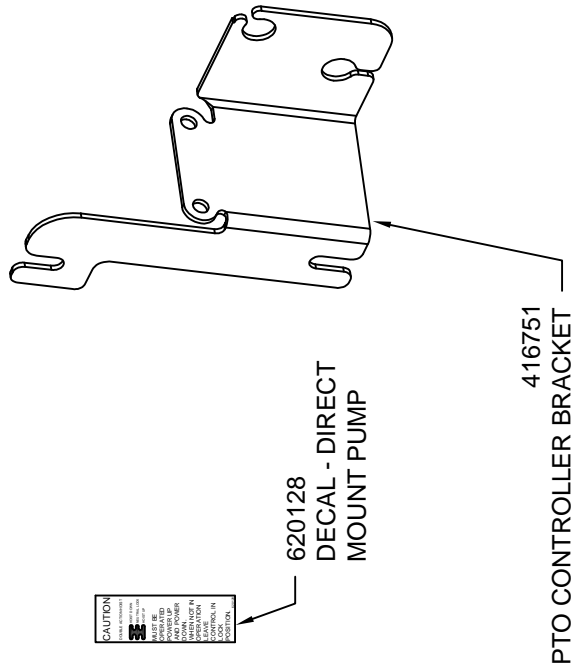
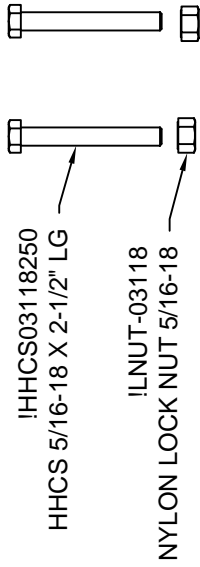

620126 CURVED HANDLE CABLE ASSEMBLY
620127 STRAIGHT HANDLE CABLE ASSEMBLY

 <p>VENCO VENTURO INDUSTRIES LLC CINCINNATI, OHIO</p>	TITLE	REPLACEMENT PARTS DWG & LIST	DATE	SECTION
		PTO PUMP CABLE	10-29-15B SUPERSEDES 03-17-14A	H400
				620245



VENCO HOISTS LIMITED WARRANTY POLICY

Venco products are built to last...we guarantee them.

As a purchaser of any new Venco product covered by warranty, you will receive 3 years of the most complete coverage available...and, at no added cost to you.

3-Year Limited Warranty Policy

This limited policy warrants new products of Venco to be free from defects in material and workmanship for a period of three (3) years from date of original installation. OEM products or accessories purchased by Venco as part of or offered with our product will carry the OEM manufacturer's respective warranty. Our warranty covers:

- ***Repair or replacement of product***
- ***Labor to repair or replace product***
- ***Freight to return and/or replace product***

We shall not be liable for any contingent liabilities arising out of the improper function of any products. Warranty shall become void if the product is improperly installed, modified, damaged, abused or used for application other than intended use. Venco hoists are designed for and intended to be used on stationary trucks dumping on firm and level ground. Spreading applications and/or shock unloading are strictly prohibited and will void this warranty. There is no warranty of merchantability, fitness for a particular purpose, warranty arising from course of dealing or usage of trade, or any other implied or expressed warranty, except as made specifically herein. This warranty supersedes all previous warranties, written or implied.

Warranty Claims

Venco Venturo Industries LLC will make a good faith effort for prompt correction or other adjustment with respect to any product, which proves to be defective after our inspection and within the warranty period. Before any repairs are attempted or before returning any product, your Venco Distributor is required to obtain a warranty claim number. This number is necessary for any claim to be considered. To obtain a warranty claim number, Venco requires the model and serial number. Only authorized Venco Distributors can perform warranty. For the name and address of your local Venco Distributor call the **Warranty Claim Department - 513-772-8448**.

WARNING - It is the responsibility of the installer to ensure the installation is completed according to the manufacturer's recommendations, ensure the ultimate user understands how to operate product in a safe manner, and understands the need for regular service and maintenance by an authorized Venco Distributor. No modifications or alterations may be made to any Venco product without the expressed written consent of Venco Venturo Industries LLC. Installation of any Venco product must be done by an authorized Venco Distributor, to the standards of the industry; including maintenance, service and affixing of all instruction, safety and warning decals. Users should be instructed as to the safe operation at time of delivery. Maintenance, service, operation and safety warning decals are available on request from Venco Venturo Industries LLC.

VENCO VENTURO INDUSTRIES LLC
12110 BEST PLACE | CINCINNATI, OHIO 45241
P: 800-226-2238 | F: 513-326-5427
www.venturo.com