



VENTURO
OWNER'S MANUAL

INST-25340

26100-PHXD

PARTS & INSTALLATION MANUAL

26100-PHXD

Included in this manual:

26100-PHXD

- Stabilizer with Dual Crosstube
- Hydraulic Pullout and Hydraulic Legs

VENCO VENTURO INDUSTRIES LLC
12110 BEST PLACE | CINCINNATI, OHIO 45241
800-226-2238



This manual also available online at www.venturo.com.

26100-PHXD

INST-25340 - 3/24/2026 (Rev: NEW0)

7607100A	SECTION 100: DESCRIPTION & SPECIFICATIONS
25480	INSTALLATION GUIDELINES
25341	INSTALLATION DIMENSIONS - SHORT LEG
25342	INSTALLATION DIMENSIONS - LONG LEG
7607200A	SECTION 200: INSTALLATION
25301	RECOMMENDED MOUNTING TO TRUCK FRAME
25447-1	SELECTOR VALVE OVERVIEW
25343	HYDRAULIC MAPPING - 1 OF 2
25344	HYDRAULIC MAPPING - 2 OF 2
25485	DEPARTURE ANGLE, REAR-MOUNTED STABILIZERS
26130	MOUNTING THE LEGS
7607400A	SECTION 400: REPLACEMENT PARTS
25345	REPLACEMENT PARTS DRAWING
25346	REPLACEMENT PARTS LIST
25216	REPLACEMENT PARTS
12-00073_VNT1	WARRANTY PAGE

SECTION 100

DESCRIPTION

&

SPECIFICATIONS



VENCO VENTURO INDUSTRIES LLC
CINCINNATI, OHIO

STABILIZER INSTALLATION GUIDELINES

Read instructions completely prior to starting installation. If this unit is to be installed on a Venturo crane body, continue to the stabilizer assembly section of this manual.

Prior to mounting the stabilizer crosstube, orient the stabilizer so the longer pullout is on the crane side of the truck.

REAR MOUNTED

Crosstube should be centered at the rear of the truck and tied into the truck frame, body longills, and crane support. Installer is responsible for proper mounting brackets and hardware that will be needed during this process. If unit is to be mounted on a service body, do not attach crosstube to body sheet metal unless otherwise specified. Allow clearance between crosstube and body for the stabilizer legs to be fully retracted. Consult chassis up-fitter guide prior to installation for proper welding and bolting procedures to chassis.

See the 'RECOMMENDED MOUNTING TO TRUCK FRAME' page

Leg installation (refer to assembly section of manual) legs are adjustable to maintain proper ground penetration of 4" to 6". The stabilizer is designed to level the truck and not lift the chassis off of the ground. They are designed to work in conjunction with the chassis suspension to stabilize the unit with the bulk of the load being supported by the chassis suspension and tires. Tires must be set at the proper pressure according to the chassis manufacture, stabilizers fully extended, and legs deployed on firm, level ground prior to crane use.

IMPORTANT - When legs are fully retracted in the stowed position, a 15° degree departure angle between the bottom of the rear tire and the lowest point of the stabilizer is recommended.

See the 'DEPARTURE ANGLE' page

For hydraulic stabilizers, the control valve and selector valve are supplied in kit. It is the installer's responsibility to supply necessary hoses and fittings between these valves and stabilizer. Refer to proper hydraulic schematic for your particular stabilizer model.

IMPORTANT - The selector valve is designed to separate the crane and stabilizer hydraulic circuits. This will not allow stabilizer use while in crane mode.

FRONT MOUNTED

Front mounted crosstube will be located on top of the chassis frame and welded to body longills. Additional shear plates (installer supplied) to be welded to crosstube and bolted to chassis frame. Crosstube to be spaced away from body for leg clearance when fully retracted. See assembly section of manual for pullout and leg installation detail.



VENCO VENTURO INDUSTRIES LLC
CINCINNATI, OHIO

INSTALLATION GUIDELINES

DATE

12-08-23A

SECTION

C200

STABILIZERS

SUPERSEDES

01-17-17

25480

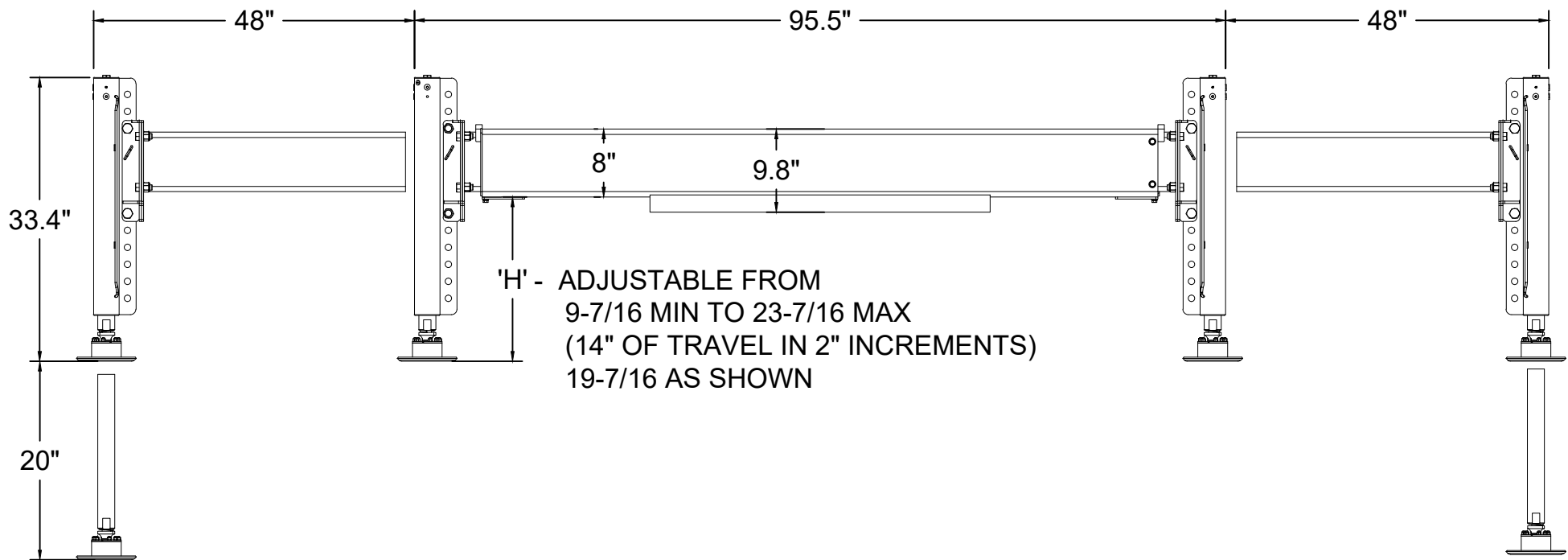
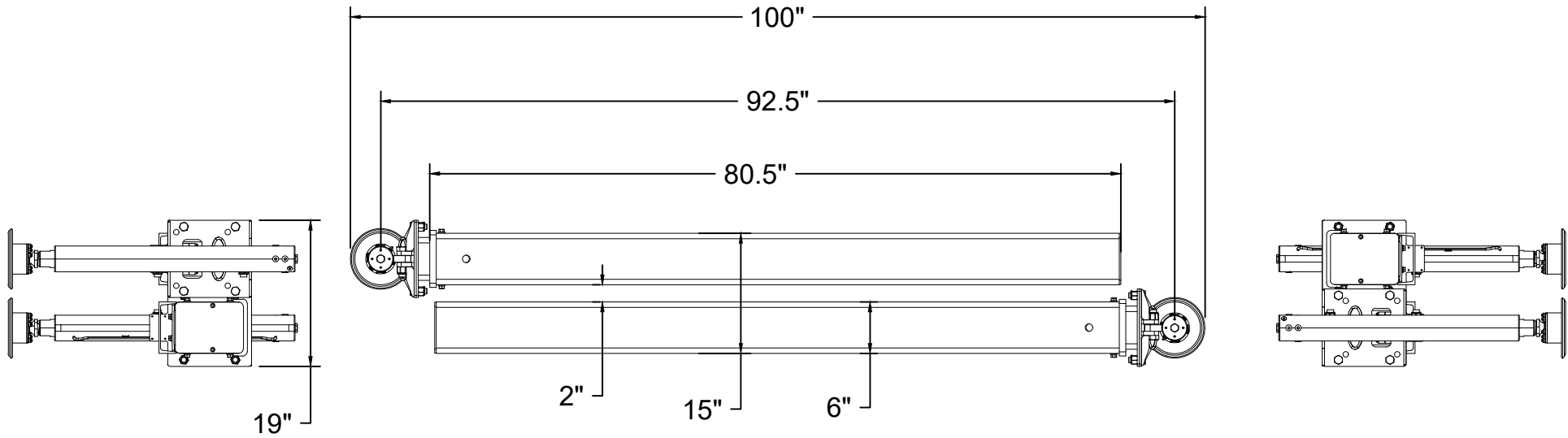

VENCO VENTURO INDUSTRIES LLC
CINCINNATI, OHIO

TITLE
INSTALLATION DIMENSIONS
26100-PHXD-SL STABILIZER

DATE
03-19-26
SUPERSEDES
-

SECTION
C100
25341

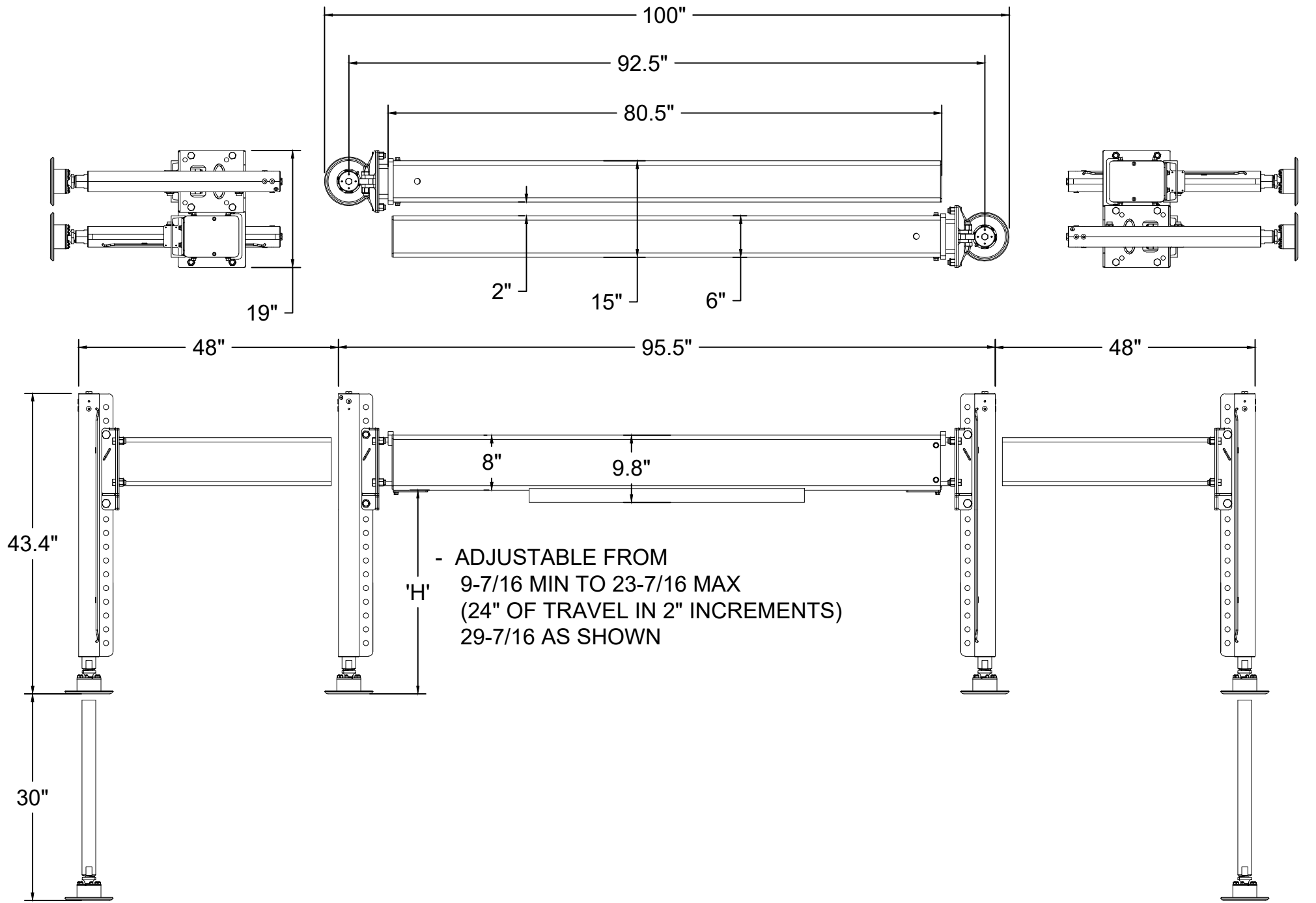

VENCO VENTURO INDUSTRIES LLC
CINCINNATI, OHIO

TITLE
INSTALLATION DIMENSIONS
26100-PHXD-LL STABILIZER

DATE
03-19-26
SUPERSEDES
-

SECTION
C100
25342

SECTION 200

INSTALLATION



VENCO VENTURO INDUSTRIES LLC
CINCINNATI, OHIO

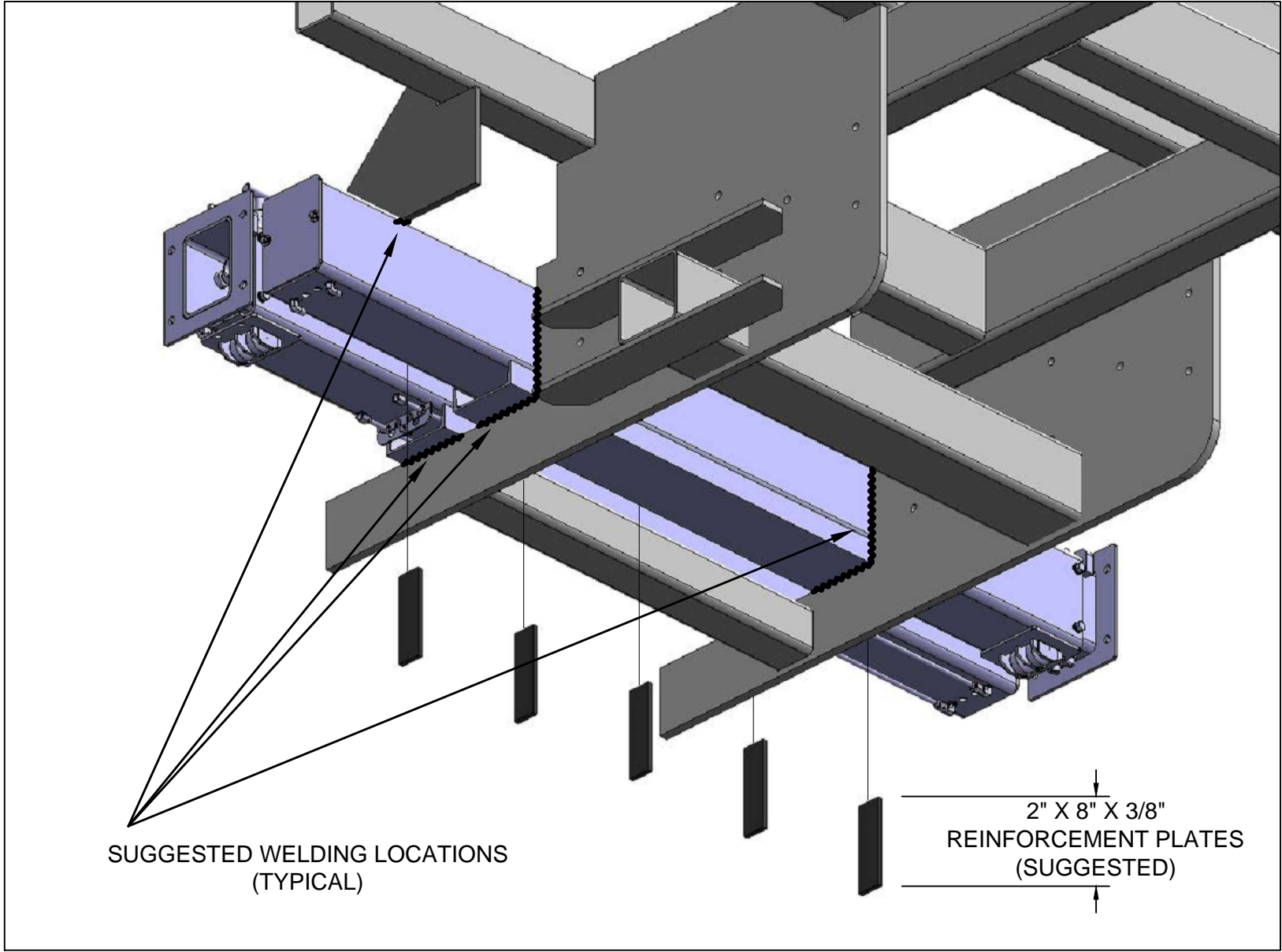

VENCO VENTURO INDUSTRIES LLC
CINCINNATI, OHIO

RECOMMENDED MOUNTING TO TRUCK FRAME

25100 DUAL-TUBE OUTRIGGERS

DATE
04-03-17

SUPERSEDES
-

PAGE

02

25301

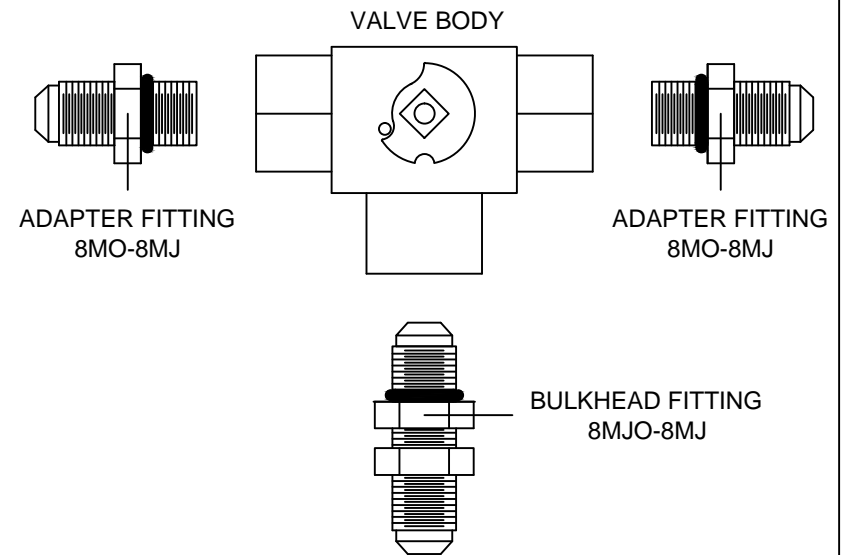
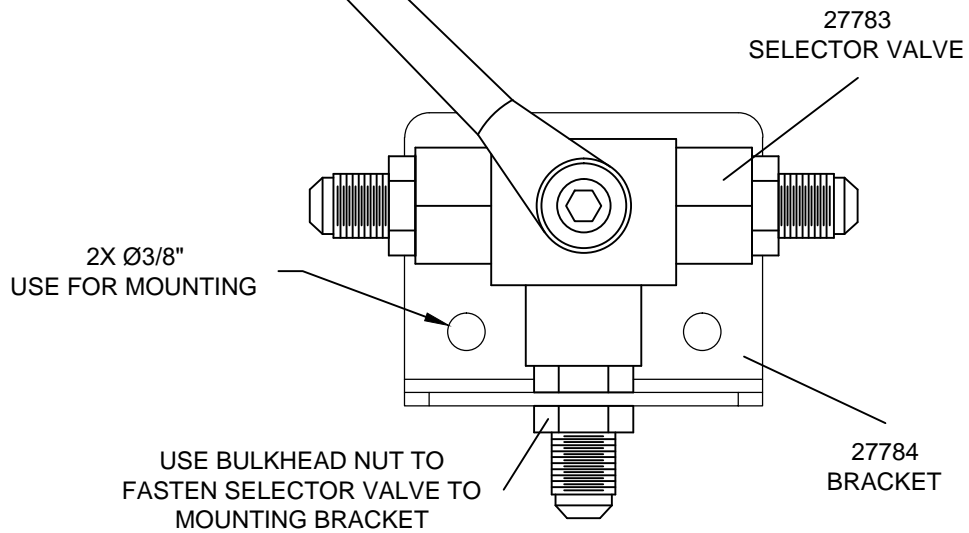
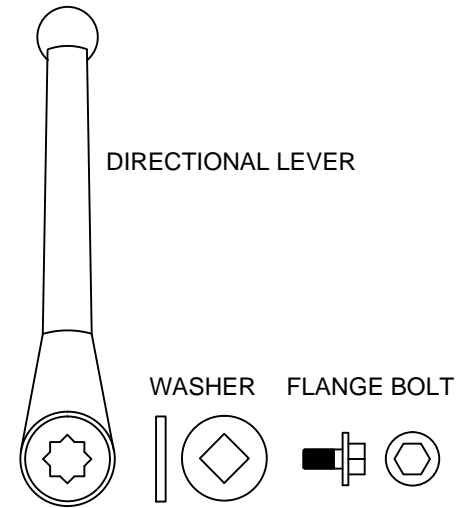
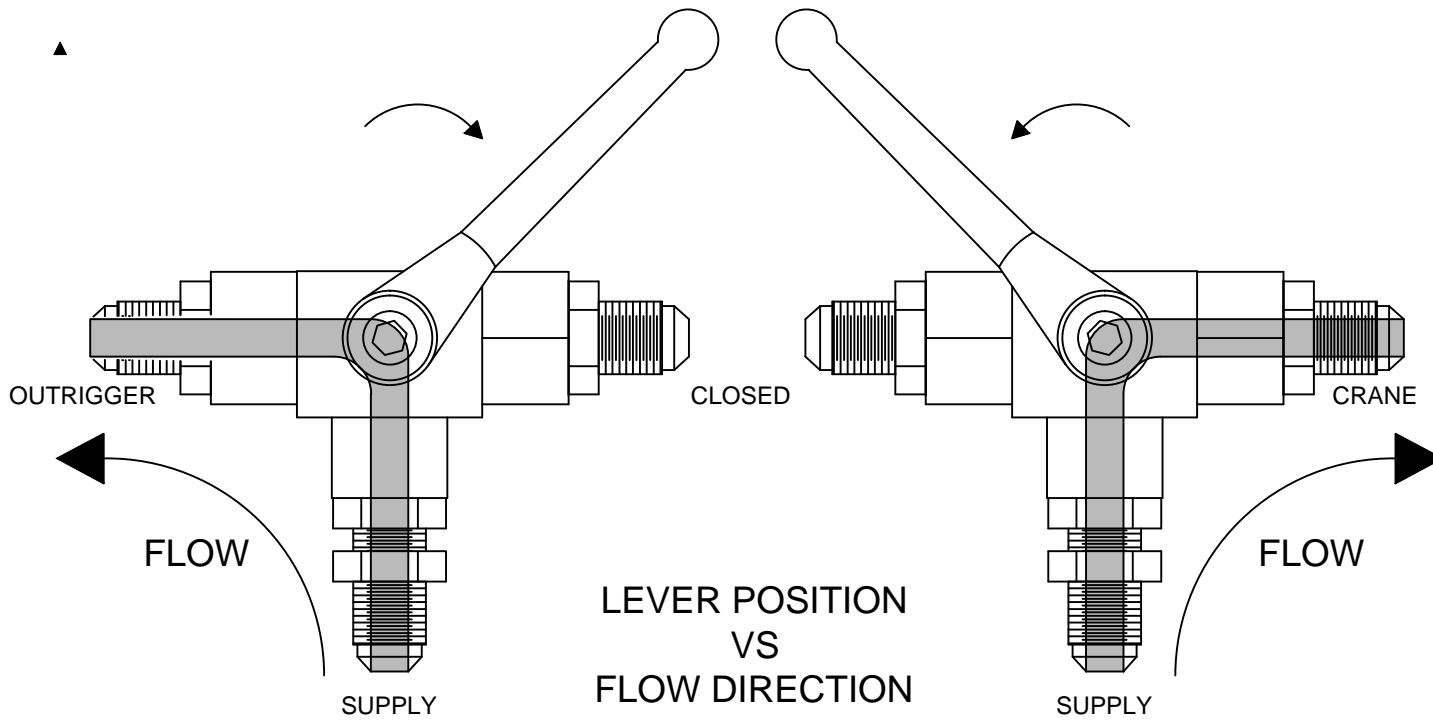

VENCO VENTURO INDUSTRIES LLC
CINCINNATI, OHIO

SELECTOR VALVE OVERVIEW

HYDRAULIC CRANES & STABILIZERS

DATE
12-07-23B

SUPERSEDES
01-20-17A

SECTION
C200

25447-1

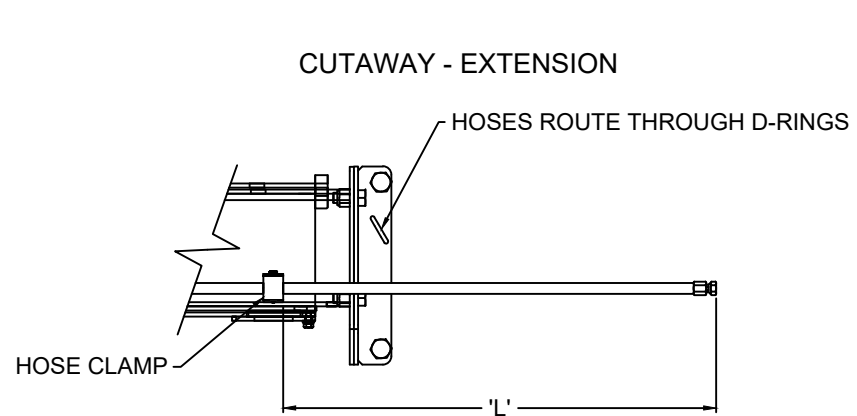
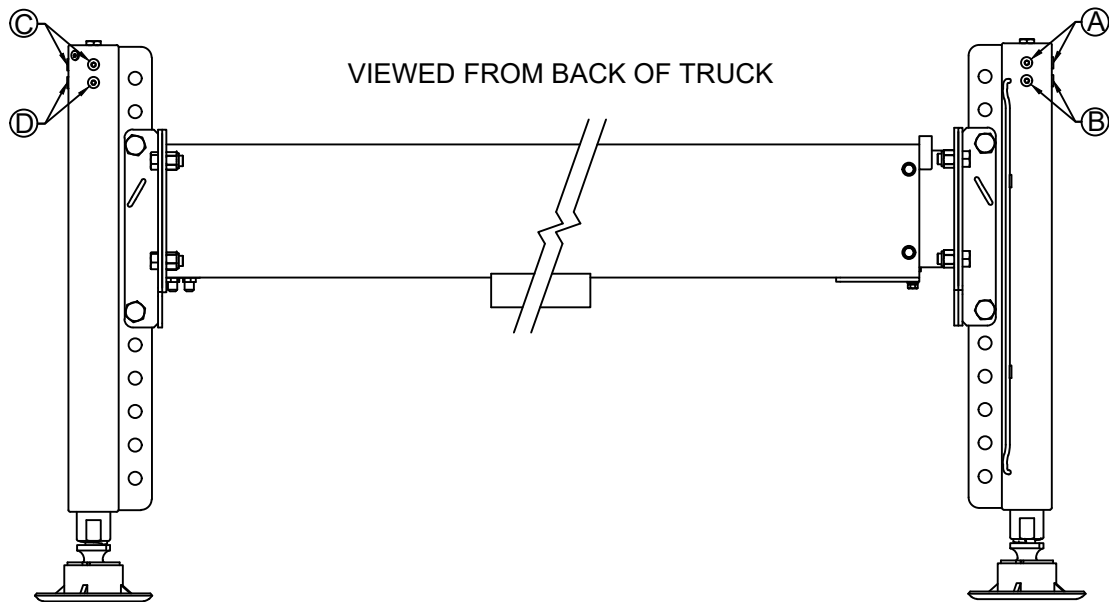

CLAMP LOCATION FOR LOOPING EXTENSION HOSE	
MODEL	'L'
26100-PHXD-SL	26 INCHES
26100-PHXD-LL	36 INCHES

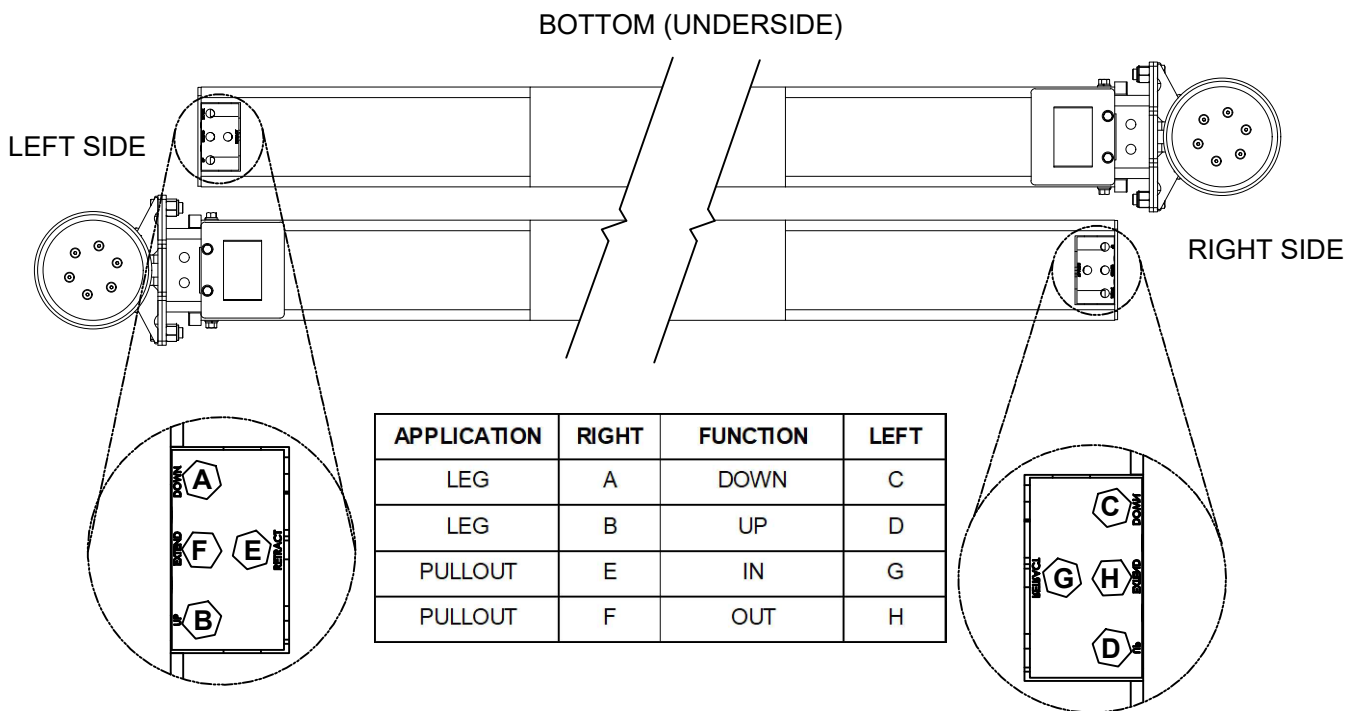

APPLICATION	RIGHT	FUNCTION	LEFT
LEG	A	DOWN	C
LEG	B	UP	D
PULLOUT	E	IN	G
PULLOUT	F	OUT	H

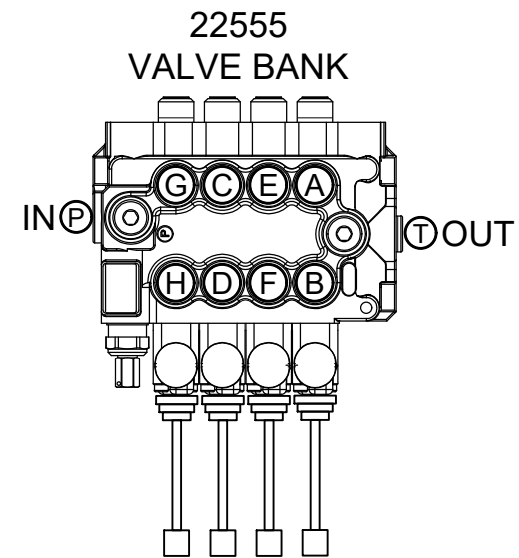

VENCO VENTURO INDUSTRIES LLC
CINCINNATI, OHIO

TITLE
HYDRAULIC MAPPING - 1 OF 2
26100-PHXD STABILIZERS

DATE
03-20-26
SUPERSEDES
-

SECTION
C200
25343

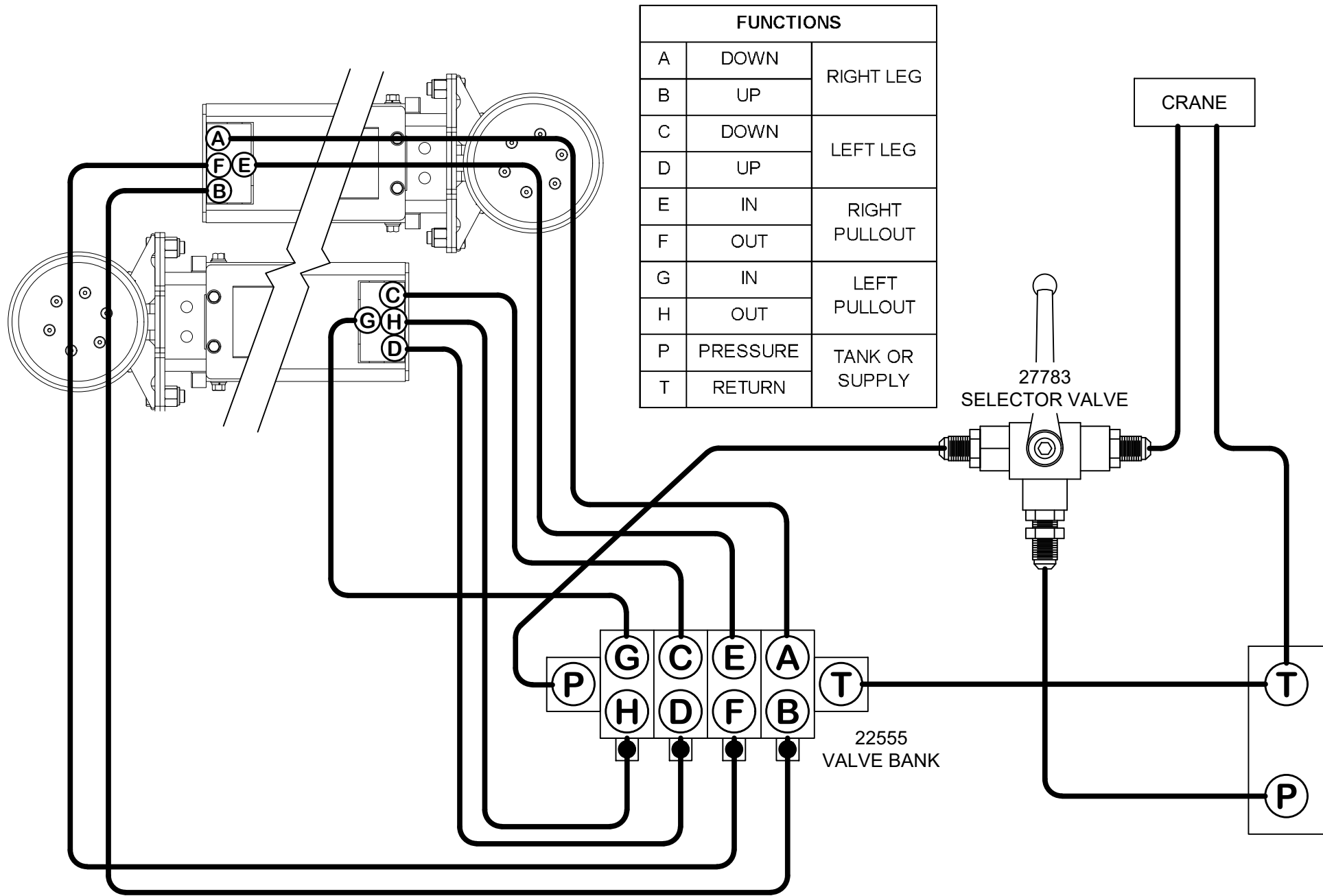

RECOMMENDED DEPARTURE ANGLE



VENCO VENTURO INDUSTRIES LLC
CINCINNATI, OHIO

RECOMMENDED DEPARTURE ANGLE

REAR MOUNTED OUTRIGGERS

DATE
08-25-22A

SUPERSEDES
01-18-17

PAGE

-

25485

MOUNTING THE STABILIZER LEGS - 25500-PHX & 26100-PHX SERIES STABILIZERS

1. Determine the desired vertical mounting position for the stabilizer legs.
2. Use the provided Hardware to attach the Leg Mounting Bar to the Mounting Adapter Plate (between the two bars): ▲
 [4] HEX HEAD CAP SCREW - 3/4-10 x 3", GR. 5, ZINC
 [4] LOCK NUT, NYLON-INSERT FULL-HEIGHT - 3/4-10, GR. 5, ZINC
3. Torque Hex Head Cap Screws to 100 ft-lb.
4. Place 24964 DANGER Decal, [1] on each Leg as shown.

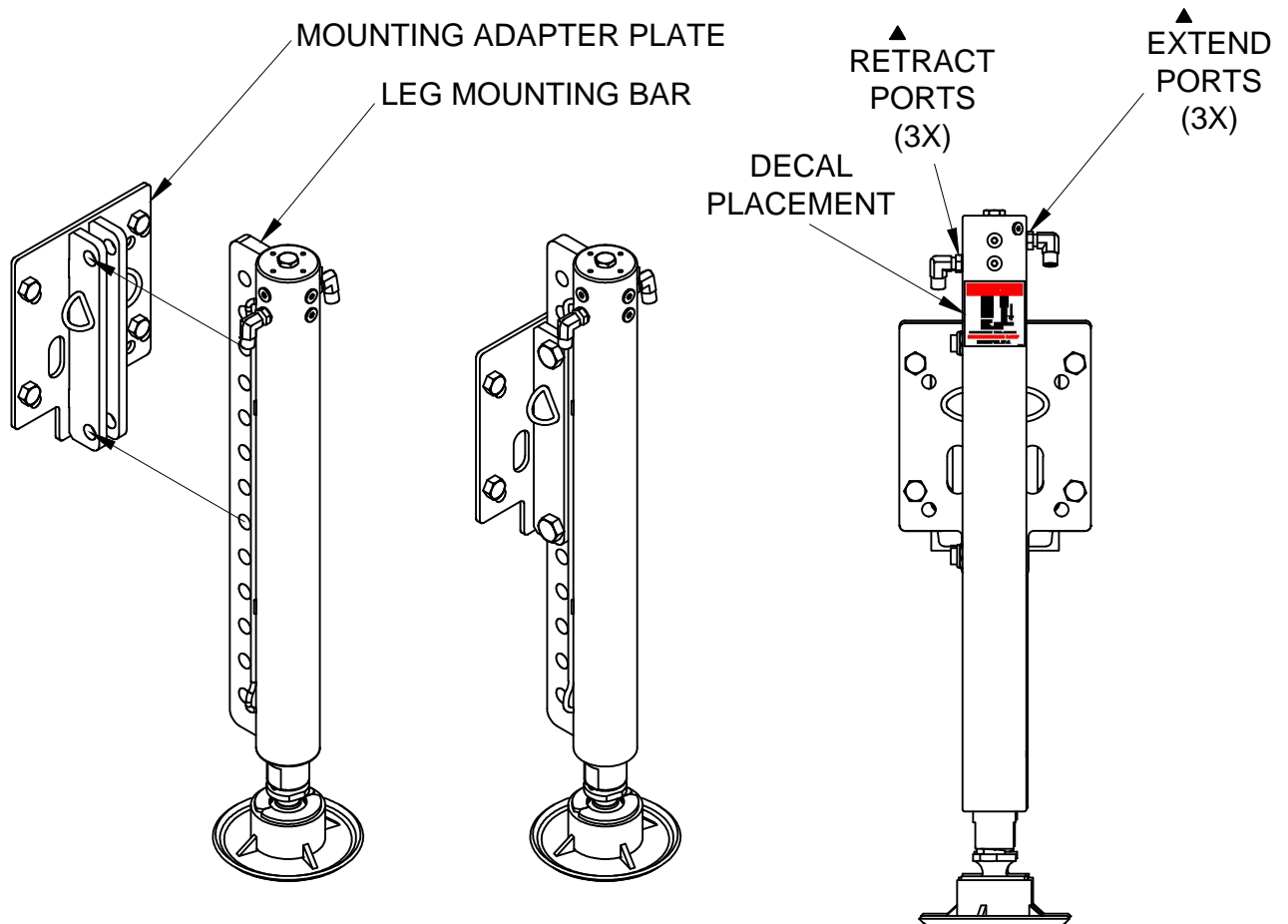

-SL ("SHORT LEG")
 CYLINDER STROKE = 20"
 VERTICAL POSITION ADJUSTABILITY = 14"
 (7 MOUNTING POSITIONS IN 2" INCREMENTS)

-LL ("LONG LEG")
 CYLINDER STROKE = 30"
 VERTICAL POSITION ADJUSTABILITY = 24"
 (12 MOUNTING POSITIONS IN 2" INCREMENTS)



VENCO VENTURO INDUSTRIES LLC
 CINCINNATI, OHIO

MOUNTING THE LEGS

25500 & 26100 STABILIZERS

DATE
 01-27-25A

SUPERSEDES
 12-14-23

SECTION
 C200

26130

SECTION 400

REPLACEMENT PARTS



VENCO VENTURO INDUSTRIES LLC
CINCINNATI, OHIO

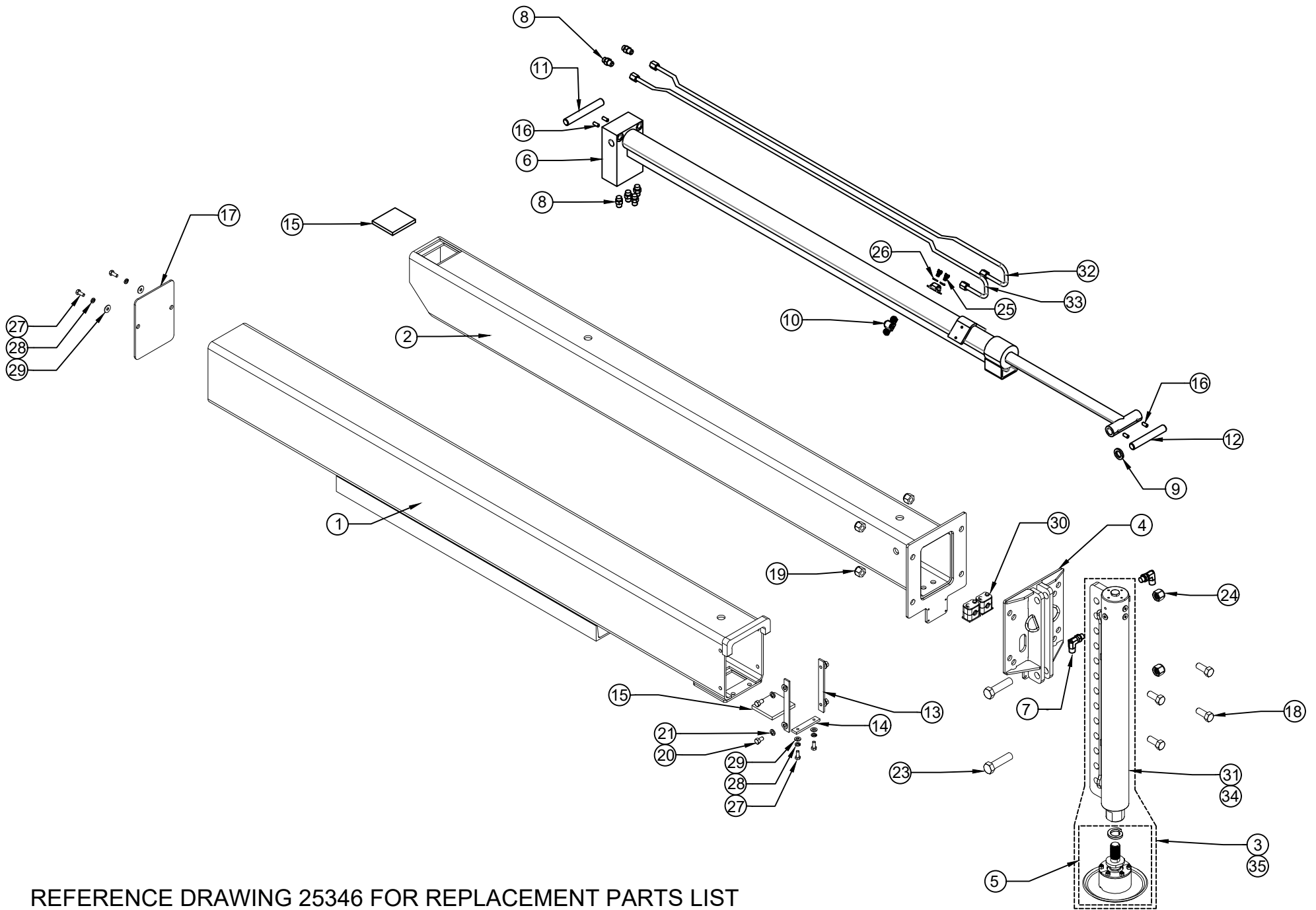

REFERENCE DRAWING 25346 FOR REPLACEMENT PARTS LIST



VENCO VENTURO INDUSTRIES LLC
CINCINNATI, OHIO

TITLE
PARTS BREAKDOWN

26100-PHXD-SL / LL

DATE
03-20-26

SUPERSEDES
-

SECTION
C400

25345

26100-PHXD-SL / -LL PARTS BREAKDOWN

ITEM #	PART #	DESCRIPTION	QTY	
			-SL	-LL
1	26101-PHXD	CROSSTUBE WELDED ASSY (PHXD)	2	2
2	26103-PHX	PULLOUT WELDED ASSY 4FT (PHX)	2	2
3	26109-SL	HYDRAULIC SHORT LEG; 20" STROKE WITH SWIVEL FOOT	2	-
4	25230	ADAPTER PLATE WELDED ASSY	2	2
5	26115	SWIVEL FOOT ASSY (ONLY); WITH LOCK WASHER	-	-
6	25231	EXTENSION CYLINDER; 48" STROKE	2	2
7	FF6801-0606	FITTING; 06MJ-06MORB 90°	4	4
8	H6400-0606	FITTING; 06MJ-06MORB	12	12
9	12534-1	MACHINERY BUSHING - 3/4" ID X 1-1/4" OD X 10 GA	2	2
10	26111	VIBRATION DAMPENING CLAMP; 3/8"	4	4
11	25051	SHAFT; EXT. BASE-END, PULLOUT	2	2
12	25052	SHAFT; EXT. ROD-END, PULLOUT	2	2
13	25065	NUT BAR; RETAINER & BEARING, CROSSTUBE SIDES	4	4
14	25077	NUT BAR; RETAINER, CROSSTUBE, BOTTOM, U.H.M.W. PAD	2	2
15	25081	UHMW PAD; BLOCK, 3/8 X 3-1/8 X 3-1/2	4	4
16	!SHCS03118063KC	SET SCREW; 5/16-18 X 5/8 - KNURLED CUP POINT	8	8
17	25183	END CAP PLATE	2	2
18	!HHCS06311150-8	HEX HEAD CAP SCREW; 5/8-11 X 1-1/2, GR. 8, ZINC	8	8
19	!LNUT-06311-8	LOCK NUT; 5/8-11, GR. 8, ZINC, NYLON-INSERT	8	8
20	!HHCS03816050	HEX HEAD CAP SCREW; 3/8-16 X 1/2, GR. 5, ZINC	8	8
21	!LWSH-038	LOCK WASHER; 3/8", GR. 5, ZINC	8	8
22	-	-	-	-
23	!HHCS07510300	HEX HEAD CAP SCREW; 3/4-10 X 3, GR. 5, ZINC	4	4
24	!LNUT-07510	LOCK NUT (FULL); 3/4-10, GR. 5, ZINC, NYLON-INSERT	4	4
25	!THCS02520038-SS	TRUSS HEAD CAP SCREW; 1/4-20 X 3/8, STAINLESS	8	8
26	!LWSH-025S	LOCK WASHER; 1/4, GR. 5, STAINLESS	8	8
27	!HHCS03118075S	HEX HEAD CAP SCREW; 5/16-18 X 3/4, STAINLESS	8	8
28	!LWSH-031S	LOCK WASHER; 5/16", STAINLESS	8	8
29	!FWSH-031S	FLAT WASHER; 5/16" X .75 O.D., 304 STAINLESS	8	8
30	26104	VIBRATION DAMPENING HOSE CLAMP; 5/8"	4	4
31	25232	HYDRAULIC SHORT LEG; 20" STROKE (CYLINDER ONLY)	-	-
32	25234-L	TROMBONE TUBE ASSY - LEFT	2	2
33	25234-R	TROMBONE TUBE ASSY - RIGHT	2	2
34	25233	HYDRAULIC LONG LEG; 30" STROKE (CYLINDER ONLY)	-	-
35	26109-LL	HYDRAULIC LONG LEG; 30" STROKE WITH SWIVEL FOOT	-	2
*	24964	DECAL; DANGER, CRUSHING INJURY	2	2
*	22555	VALVE BLOCK, 4-SPOOL	1	1
*	H6400-0808	ADAPTER FITTING; STRAIGHT, 8MJ-8MO	2	2
*	H6400-0608	ADAPTER FITTING; STRAIGHT, 6MJ-8MO	8	8
*	27783	SELECTOR VALVE	1	1
*	27784	BRACKET, SELECTOR VALVE	1	1
*	22765-2	CARTRIDGE VALVE - PILOT OPERATED CHECK (FOR 25232 CYLINDER)	-	-
*	25218	HANDLE, AL001, M8 THD X 150MM	-	-
*	25219	LEVER BOX L100, M8	-	-

REFERENCE DRAWING 25345 FOR REPLACEMENT PARTS DRAWING



VENCO VENTURO INDUSTRIES LLC
CINCINNATI, OHIO

TITLE
PARTS BREAKDOWN

DATE
03-20-26

SECTION
C400

26100-PHXD-SL / LL

SUPERSEDES
-

25346

22555

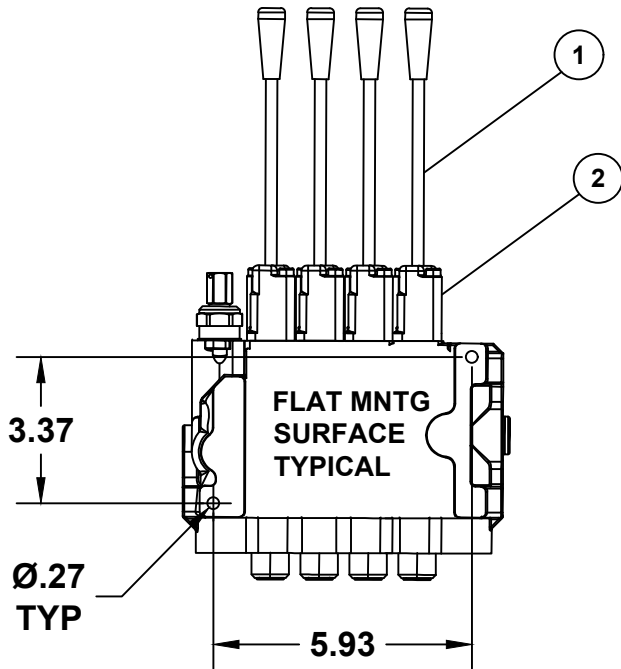

25050

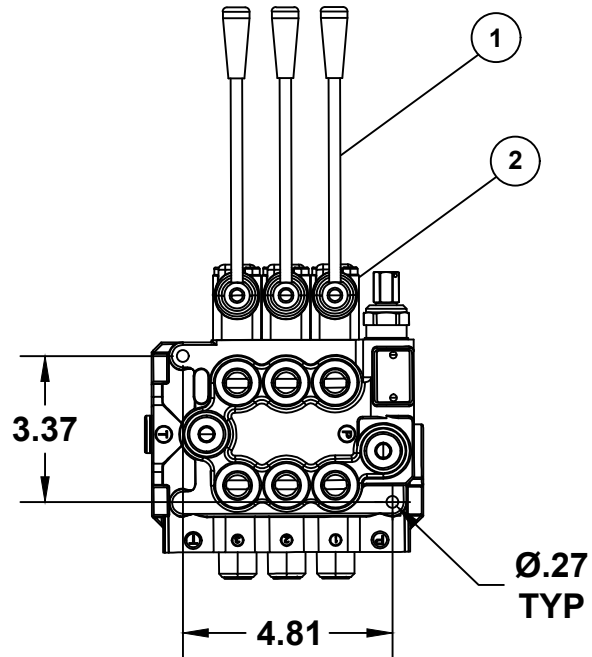

22444

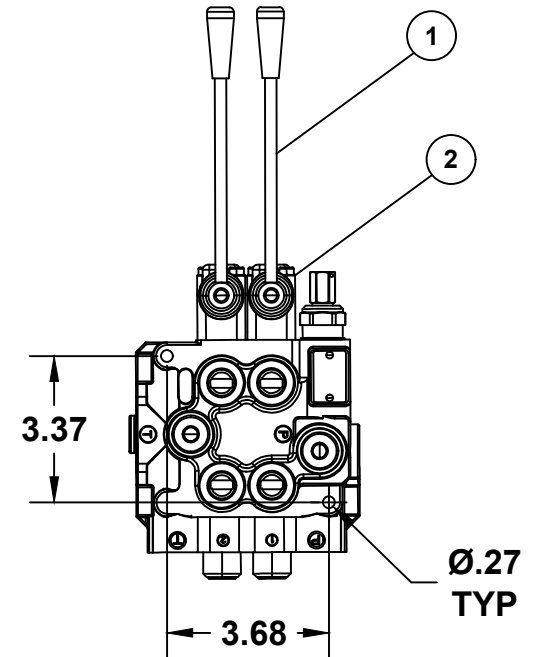

NOTE:
P/N 25219 INCLUDES
MNTG HARDWARE

ITEMS 3 & 4 NOT SHOWN

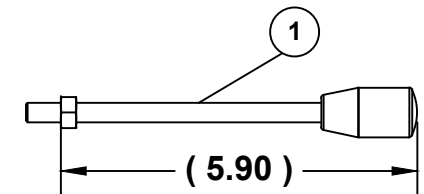
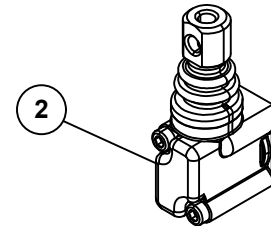

ITEM NO.	SPOOL VALVE ASSEMBLIES			PART NO.	DESCRIPTION
	22444	25050	22555		
	QTY.				
1	2	3	4	25218	HANDLE, BUCHER SPOOL VALVES
2	2	3	4	25219	LEVER BOX, BUCHER SPOOL VALVES
3	2	3	4	25209	BUCHER SEAL KIT, SINGLE SECTION
4	2	3	4	25213	CENTER SPRING KIT, SINGLE SECTION



MANUFACTURING, INC.
CINCINNATI, OHIO

TITLE
REPLACEMENT PARTS - SPOOL VALVES
POWERED STABILIZERS (PH, PHX, PHXD)

DATE
09-24-25
SUPERSEDES
-

PAGE
-
25216



VENTURO CRANES LIMITED WARRANTY POLICY

Venturo products are built to last...we guarantee them.

As a purchaser of any new Venturo product covered by warranty, you will receive 1 year of the most complete coverage available...and, at no added cost to you.

1-Year Limited Warranty Policy

This limited policy warrants new products of Venturo to be free from defects in material and workmanship for a period of one (1) year from date of original installation. OEM products or accessories purchased by Venturo as part of or offered with our product will carry the OEM manufacturer's respective warranty. Our warranty covers:

- ***Repair or replacement of product***
- ***Labor to repair or replace product***
- ***Freight to return and/or replace product***

We shall not be liable for any contingent liabilities arising out of the improper function of any products. Warranty shall become void if the product is improperly installed, modified, damaged, abused or used for application other than intended use. There is no warranty of merchantability, fitness for a particular purpose, warranty arising from course of dealing or usage of trade, or any other implied or expressed warranty, except as made specifically herein. This warranty supersedes all previous warranties, written or implied.

Warranty Claims

Venco Venturo Industries LLC will make a good faith effort for prompt correction or other adjustment with respect to any product, which proves to be defective after our inspection and within the warranty period. Before any repairs are attempted or before returning any product, your Venturo Distributor is required to obtain a warranty claim number. This number is necessary for any claim to be considered. To obtain a warranty claim number, Venturo requires the model and serial number. Only authorized Venturo Distributors can perform warranty. For the name and address of your local Venturo Distributor call the **Warranty Claim Department - 513-772-8448**.

WARNING - It is the responsibility of the installer to ensure the installation is completed according to the manufacturer's recommendations, ensure the ultimate user understands how to operate product in a safe manner, and understands the need for regular service and maintenance by an authorized Venturo Distributor. No modifications or alterations may be made to any Venturo product without the expressed written consent of Venco Venturo Industries LLC. Installation of any Venturo product must be done by an authorized Venturo Distributor, to the standards of the industry; including maintenance, service and affixing of all instruction, safety and warning decals. Users should be instructed as to the safe operation at time of delivery. Maintenance, service, operation and safety warning decals are available on request from Venco Venturo Industries LLC.

VENCO VENTURO INDUSTRIES LLC
12110 BEST PLACE | CINCINNATI, OHIO 45241
P: 800-226-2238 | F: 513-326-5427
www.venturo.com